

ESCOGEAR C series

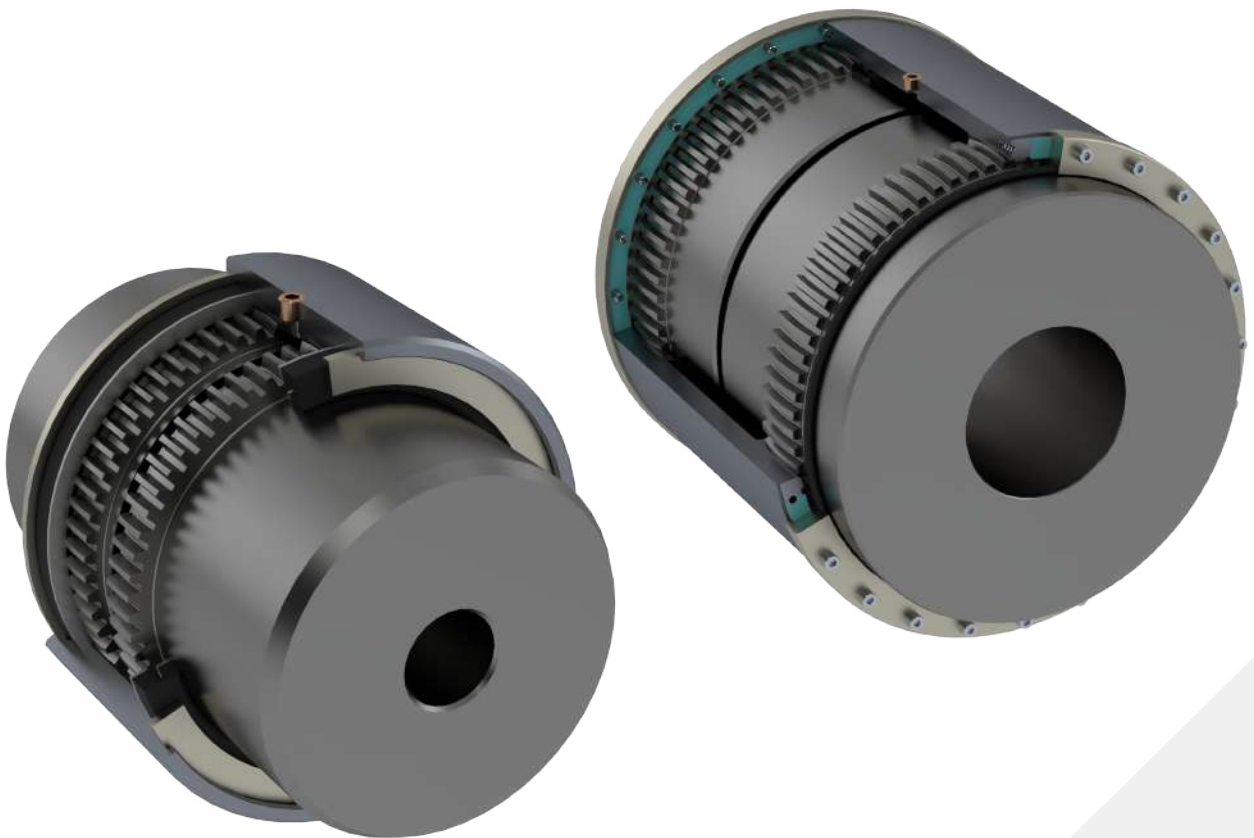

EXPERTISE DRIVEN | CUSTOMER FOCUSED | SUSTAINABLE THINKERS

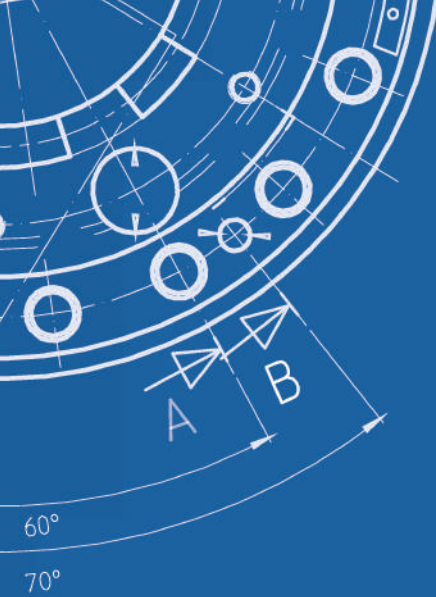

INDEX

We connect the world	5	CMM...N/CSUMM...N 280N - 450N	31
Global footprint	6	CDMM/CSUDMM 30 - 100	32
The right solution for your application	8	CDMM...M/CSUDMM...M 110M - 275M	33
Why ESCOGEAR C?	10	CDMM...N/CSUDMM...N 280N - 450N	34
Notes	13	CCO/CSUCO 30 - 100	35
Availabilities	14	CCO...M/CSUCO...M 120M - 270M	36
How to select the right coupling size	16	CSH/CSUSH 30 - 100	37
Notes	19	CSH...M/CSUSH...M 110M - 275M	38
CST/CSU 30 - 100	20	Notes	39
CST/CSUST 110M - 275M	21	CSV/CSUV 30 - 100	40
CSS...M/CSUSS...M 110M - 275M	22	CSV...M/CSUV...M 110M - 275M	41
CST...N/CSU...N 280N - 450N	23	CSV...N/CSUV...N 280N - 450N	42
CFS/CSUFS 30 - 100	24	Further details and options	43
CFS...M/CSUFS...M 110M - 275M	25	Further designs and combinations	45
CFS...N/CSUFS...N 280N - 450N	26	Installation and maintenance	46
CFS/CSUFS Assembly 30 - 100	27	Notes	51
CFS...M/CSUFS...M Assembly 110M - 275M	28	ATEX	52
CMM/CSUMM 30 - 100	29	Contact us!	54
CMM...M/CSUMM...M 110M - 275M	30		





We connect the world

We are more than a 75 years old family-owned company specialized in designing and manufacturing high-quality custom-made power transmission products.

Because we believe each transmission challenge is different, we create much more than off-the shelf products: we work hand in hand with our customers to develop the coupling solutions that best fit their specific needs.

Superior product quality is what guarantees our customer's success, it is what enables us to cherish long term partnerships with them. The ESCO quality has been worldly renown for decades and we work tirelessly to raise these standards even further.

We strive to be a significant contributor to the development of effective and clean industrial, transportation and energy supply applications. We want our couplings to power a more sustainable world.

We strongly believe that both the future of our economy and the best guarantee for long term return lie in sustainable development. And we want to do our part.

Once we get involved into a specific sector, we make sure to embrace the quality standards that the market requires. This is why, we are ISO 9001 certified.



A global footprint, with a family of
9 companies located all across the world



9

offices across
the world

3

manufacturing
sites

● ESCO Couplings SRL
Saintes, Belgium
Tel. +32 (0) 2 715 65 60
info@esco-couplings.be

● ESCO Couplings & Transmissions Pvt. Ltd.
Bengaluru, India
Tel. +91 80 7100 1800
info@esco-couplings.co.in

● ESCO Power SRL
Saintes, Belgium
Tel. +32 (0) 2 717 64 90
info@escopower.be

● EFECO Services Pvt. LTd
Bengaluru, India
Tel. +91 80 4977 7088

● ESCO Couplings Ltd.
Jinan, China
Tel. 86 (531) 827 625 65
info@esco-couplings.com



- Head-office & Manufacturing site
- Manufacturing sites
- Sales offices & Service centres

● ESCO Aandrijvingen B.V.
Alphen A/D Rijn, The Netherlands
Tel. +31 (0) 172 42 33 33
info@esco-aandrijvingen.nl

● esco antriebstechnik gmbh
Troisdorf, Germany
Tel. +49 (0) 2241 48 07 0
info@esco-antriebstechnik.com

● ESCO Drives SRL
Saintes, Belgium
Tel. +32 (0) 2 717 64 60
sales@esco.be

● ESCO Transmissions SAS.
Saint Witz, France
Tel. +33 (1) 34 31 95 95
info@esco-transmissions.fr

We work with you to design the right
solution for your application





Versatility, robustness, efficiency and long life, these are only a few of the many high demands on the gear couplings. These properties are the reason why gear couplings are that popular in multiple industries as they can get along with all different harsh conditions.

Since the competitiveness of the technical and economic aspects of the production needs to be more and more effective in the long-term, the machines used in the applications need to be able to run continuously, without failure. Furthermore, maintenance operations should be as short and seamless as possible to minimize costly production down time.

Minimizing the life cycle cost of the installation requires careful attention when selecting the elements of the driveline. A high-quality coupling will make a difference between an efficient, cost effective transmission, and a poorly optimized one.

This is where ESCO can help you. We have been helping our customers by designing high-quality tailor-made couplings for more than 40 years:

Quality is our motto, our core competency: ESCO products are amongst the most reliable in the market; so much so that the main hurdle in our capacity to innovate is the lack of market feedback: our couplings just keep running without issues.

Low lifecycle cost might well be the biggest challenge for ESCO to tackle, but we do work tirelessly to optimize the life time value of our couplings: fair initial price, smaller footprint (space and weight), longer design life, lubrication-free alternatives, extended maintenance steps...

Service is an important part of our business: to best serve your needs, you can count on our experienced team and advanced testing capability. We are more than happy to assist in performing field interventions, maintenance and repair.

Our relationship with customers does not stop once couplings are delivered. We have a team of experienced people ready to perform service on the field, repair, inspections, testing... We can also do the maintenance on our couplings for you. This guarantees proper execution of the maintenance instructions and contributes to improving the lifetime of your application.

ESCO specializes in the design of custom made couplings. If you cannot find a solution that fits your needs, please contact us: we will work hard to engineer the coupling that fits your application specifications.

Why ESCOGEAR C?

Improves efficiency of machine design and coupling selection

High torque and misalignment capacity – Compact design

Thanks to the patented ESCOGEAR Multicrown profile (used on the C..., C...M & C...N series), the optimised coupling design and the standard use of 12.9 quality bolts, the ESCOGEAR couplings offer the user a very high torque capacity. This means that for a given torque a smaller coupling can be used which results in more efficient machine design and performance. Furthermore, this high torque is available at important angular misalignment.

Torque capacity independent from misalignment – Transparent coupling selection

The torque capacity of a gear type coupling strongly depends on the angular misalignment to which it is subjected: the higher the misalignment, the lower the torque capacity. It is clear that this relationship can and will cause problems in coupling selection because misalignment during operation is almost impossible to predict. ESCOGEAR couplings of the C..., C...M & C...N types are equipped with the ESCO Multicrown tooth form. Thanks to this quite unique design, the ESCOGEAR has a torque capacity that is practically independent of the angular misalignment. Therefore, coupling selection is easy and mistakes are avoided: long coupling life is guaranteed.

Extends installation lifetime

High precision gearing – Higher quality, more reliable coupling

Pitch error in the gearing of coupling can strongly affect the load distribution between the teeth can be strongly influenced. In some cases, the maximum load applied on the teeth can be twice the value of the load calculated. The consequence will be higher surface and root stresses and coupling failure might be the result. Thanks to the high precision manufacturing process and equipment on which all ESCOGEAR couplings are manufactured and the sophisticated quality control, pitch error is minimized and the best possible gear quality level and life time can be guaranteed.

Reduced backlash – Reduced load during start/stop and reverse torque applications

Due to the Multicrown design necessary backlash between the teeth can be reduced to an absolute minimum. This will reduce the impact loads in start/stop and reserve torque applications. As a result, the teeth can be designed with a larger profile and the root stresses will be reduced. Thanks to this feature the ESCOGEAR couplings are ideal for use in presses, mills, punching machines, portal cranes, pumps, conveyors etc...

Perfect gear top centering – Reduced vibrations

Gear type couplings require, in order to operate, a “clearance” between the top of each hub tooth and the root of the sleeve teeth. Due to this clearance, the sleeve cannot be perfectly centred on the hubs. This will create vibrations in applications where the load constantly changes from no load to full load (e.g. portal cranes). These vibrations will of course influence the operation of the connected equipment. Thanks to special design and machining techniques, ESCO is able to pilot the top of each hub tooth into the root of the sleeve teeth. By doing so, the sleeve will remain perfectly centred on the hub and vibrations will be avoided. This specific feature is standard on all C..., C...M & C...N couplings.

Special surface treatment and coating – Excellent protection of components

In order to guarantee optimum operation, all ESCOGEAR couplings are protected with special surface treatment or coating. All bolts are coated with Geomet and the nuts are zinc plated which gives an excellent corrosion resistance and makes disassembly possible, even after numerous years of service life. Furthermore, all the steel components are protected with a special coating to improve their corrosion resistance.

CST

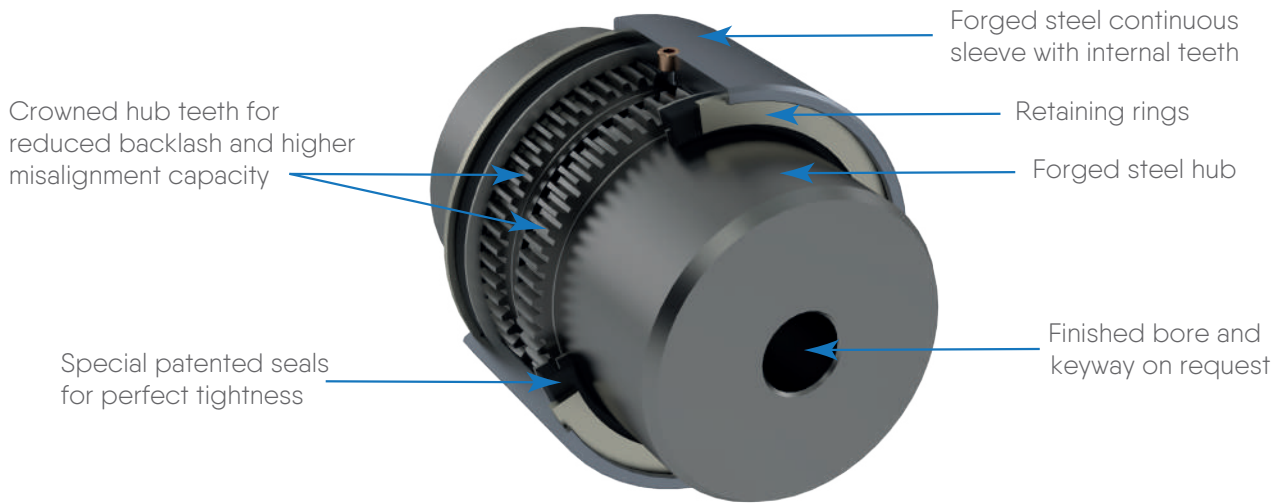

CST...M/CST...N

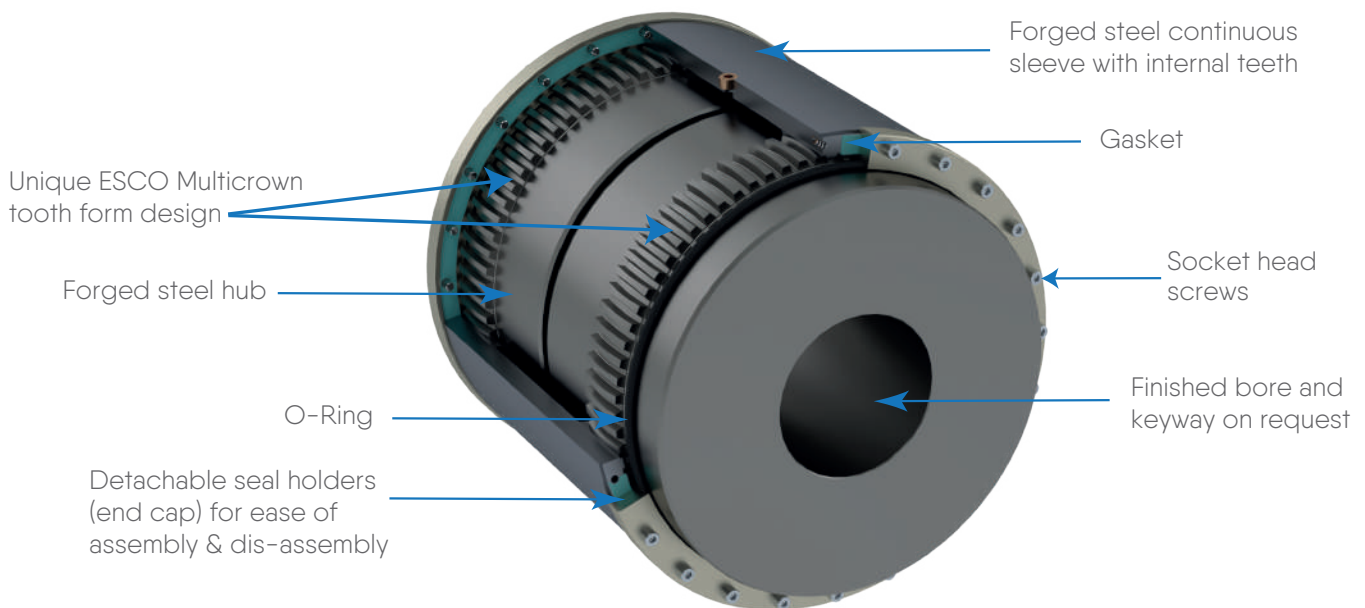

Most compact solution

Thanks to the high torque capacity and the continuous sleeve design, the escogear C, C...M & C...N couplings are the most compact answer to any transmission applications. In comparison to other types of couplings and for a given torque they have a substantially lower weight and reduced they have a substantially lower weight and reduced outside diameter:

- Flanged Gear type : 17% smaller O.D.
- Disc type: 30% smaller O.D.
- Elastic type : 52% smaller O.D.

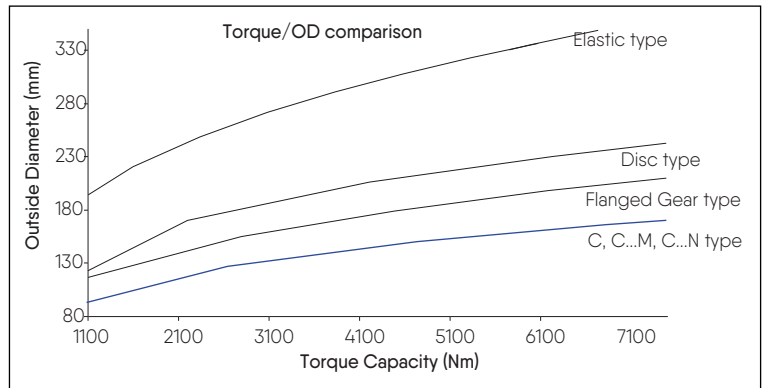

This compactness makes the escogear C series ideal for use in applications where space is limited and weight important.

ESCO Multicrown tooth form design: Technical features

Lower stresses

The ESCO Multicrown tooth form is a curve with constantly changing radii of curvature. The tooth contact area under misaligned conditions has a much larger radius of curvature than conventional crowning. The contact area therefore is larger thus reducing the surface stresses.

Constant velocity power transmission

ESCO generates the ESCO Multicrown tooth in such a way that the necessary characteristics for homokinetic conjugate tooth action are perfectly achieved.

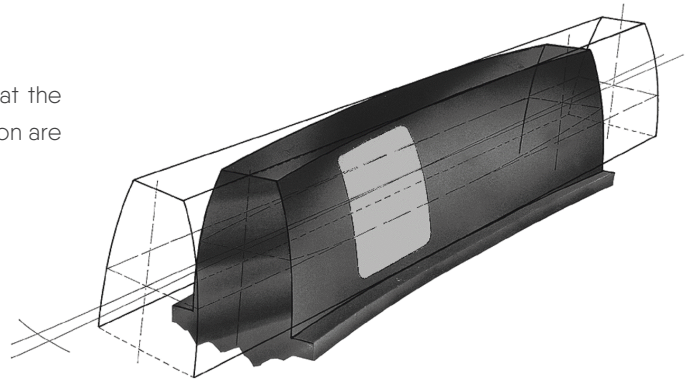

Less backlash

The ESCO Multicrown tooth design requires less backlash for a given angle of misalignment than the conventional crowning, thus reducing shocks in reversing application.

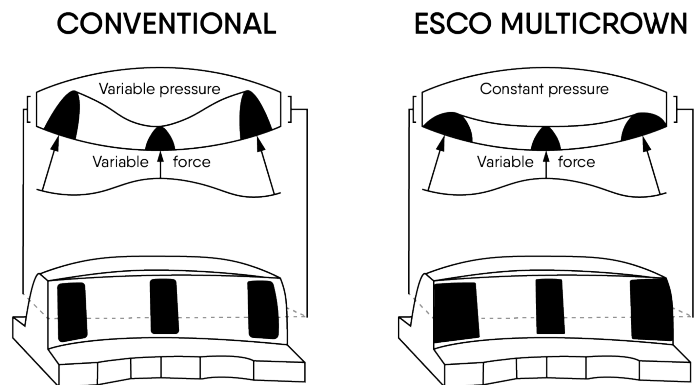

Notes:

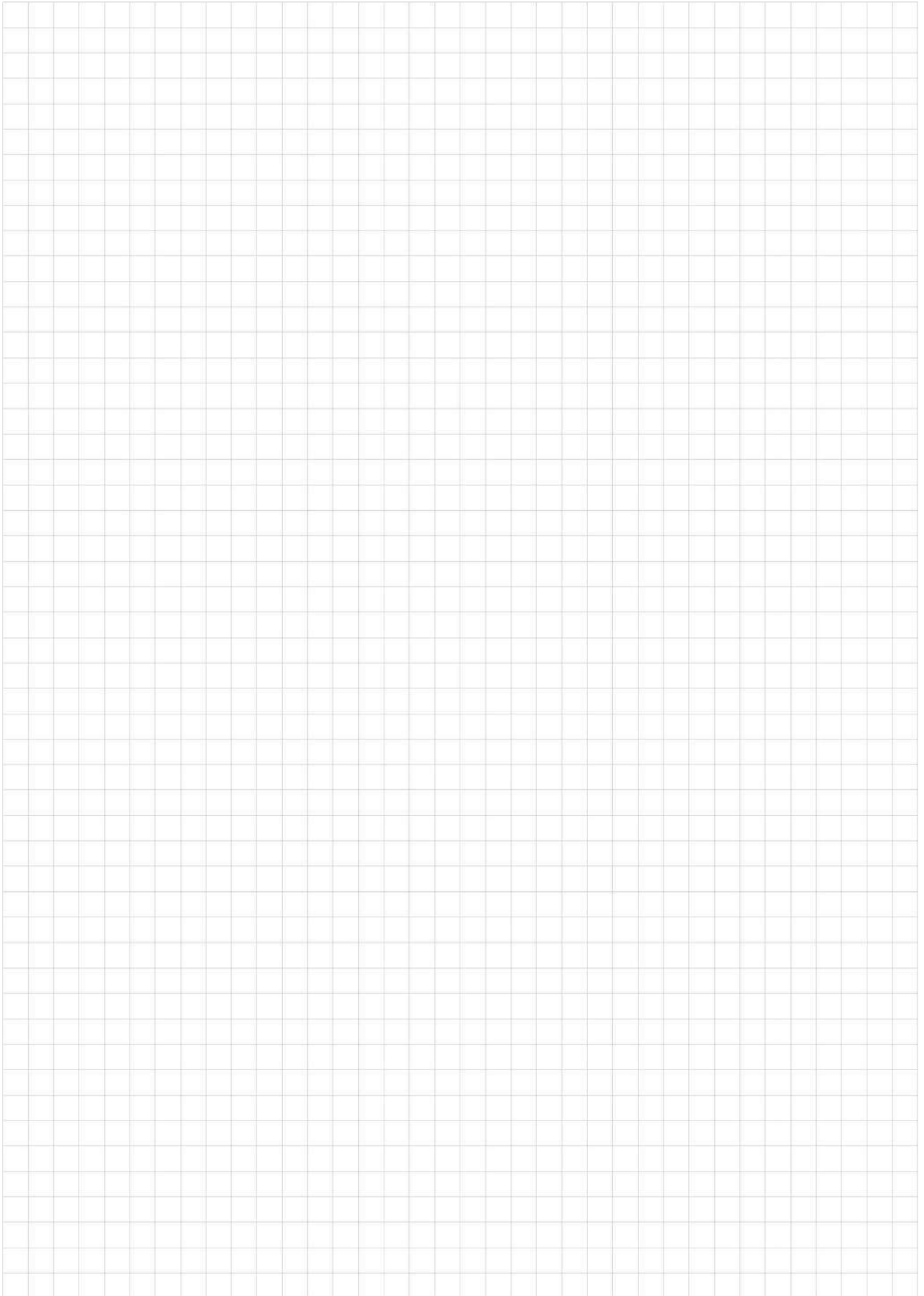

Availabilities

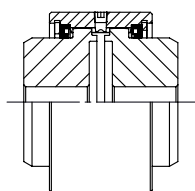

CST/CSU
STANDARD
B3100a
Page 20

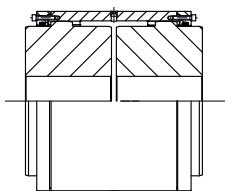

CST...M/CSU...M
STANDARD
B3101a
Page 21

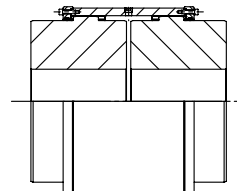

CSS...M/CSUSS...M
SHORT SLEEVE
B3102a
Page 22

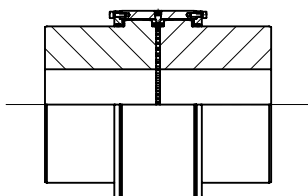

CST...N/CSU...N
STANDARD
B3103a
Page 23

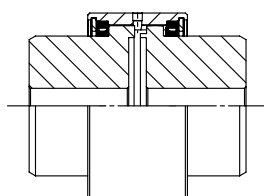

CFS/CSUFS
FLOATING SHAFT
B3110a
Page 24

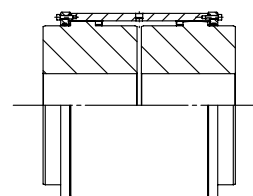

CFS...M/CSUFS...M
FLOATING SHAFT
B3111a
Page 25

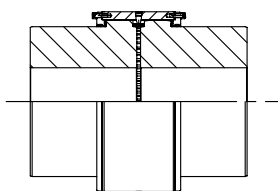

CFS...N/CSUFS...N
FLOATING SHAFT
B3112a
Page 26

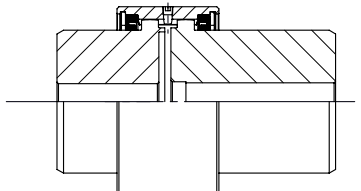

CMM/CSUMM
MILL MOTOR
B3120a
Page 29

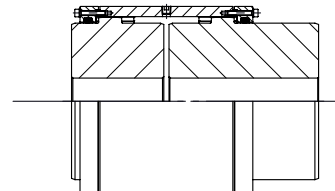

CMM...M/CSUMM...M
MILL MOTOR
B3121a
Page 30

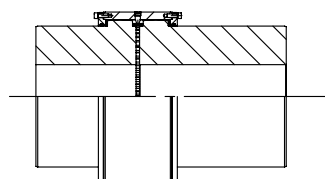

CMM...N/CSUMM...N
MILL MOTOR
B3122a
Page 31

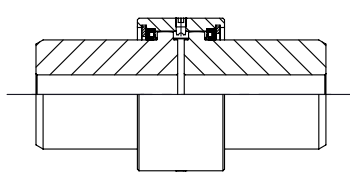

CDMM/CSUDMM
DOUBLE MILL MOTOR
B3130a
Page 32

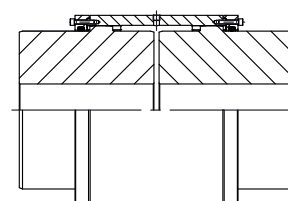

CDMM...M/CSUDMM...M
DOUBLE MILL MOTOR
B3131a
Page 33

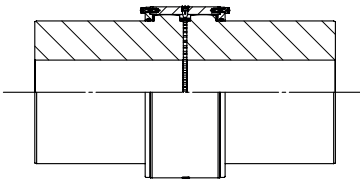

CDMM...N/CSUDMM...N
DOUBLE MILL MOTOR
B3132a
Page 34

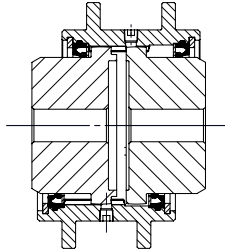

CCO/CSUCO
CUT-OUT
B3140a
Page 35

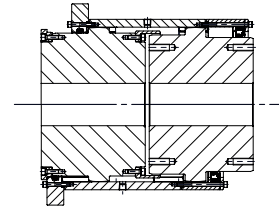

CCO...M/CSUCO...M
CUT-OUT
B3141a
Page 36

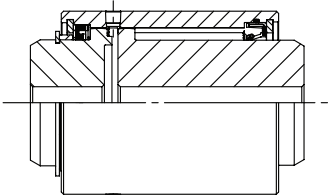

CSH/CSUSH
SLIDING HUB
B3150a
Page 37

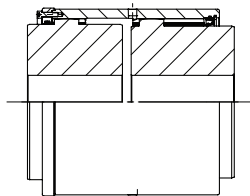

CSH...M/CSUSH...M
SLIDING HUB
B3151a
Page 38

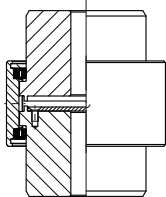

CSV/CSUV
STANDARD VERTICAL
B3160a
Page 40

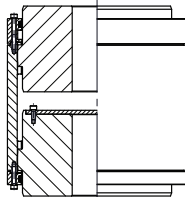

CSV...M/CSUV...M
STANDARD VERTICAL
B3161a
Page 41

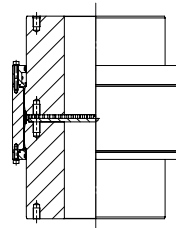

CSV...N/CSUV...N
STANDARD VERTICAL
B3162a
Page 42

In the follow-up you will find the chapters "Further details and options" and "Further design and combinations" for more information.

How to select the right coupling size

Coupling size selection

To be sure to select the right ESCOGEAR C coupling for your application, it is necessary to know the following preliminary data:

- The shaft diameter
- The type of driving machine
- The type of driven machine
- The duration and type of the daily service
- The application peak torque
- The presence of shocks or very high load peaks

To select the right ESCOGEAR C coupling size, please follow these steps:

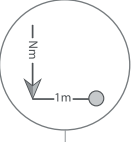
- ① 

Calculate the required torque capacity by using this formula: $T = \frac{9550 \times P \times F_u \times F_{\text{exp}}}{n}$ with

 - a. P = power in kW
 - b. n = speed in rpm
 - c. F_u = service factor according to the application (see TABLE 1).
 - d. $F_{\text{exp}} = 2$ in case of use in potentially explosive atmospheres , European Directive 94/9/EC. In normal atmospheres, $F_{\text{exp}} = 1$.

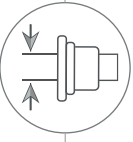
- ② 

Select the size of ESCOGEAR C coupling that will accommodate the largest shaft diameter (see Technical data tables, Ød max. = Maximum possible bore).

- ③ 

Make sure the selected coupling has an equal or greater torque capacity than the result figure obtained in ①. If it is not the case to be used, please select a larger size coupling.

 - Check if the application peak torque does not exceed the chosen coupling peak torque (see Technical data tables, T_p = Maximum peak torque).
 - Check the maximum allowable misalignment using the graph of  (see TABLE 2).
 - Check if the shaft/hub connection will transmit the torque.
If necessary, select a longer hub.

- ④ 

Read carefully the Assembly and Maintenance Instructions IM/B300a.

Table 1: Service factor (F_u)

For ATEX applications the minimum Service Factor (F_u) should be 2.0 independently of the below given values.

Applications		DRIVER MACHINE			
		Electric motors & Turbines	Hydraulic motors & Gear drivers	Reciprocating engine & Electric motors frequent starts	
		Service Factor F_u			
DRIVEN MACHINES	UNIFORM	Generators - Blowers: centrifugal vanes, fans - Centrifugal pumps & compressors - Machine tools: auxiliary drives - Conveyors: belt and chain, uniformly loaded, escalators - Can filling machines & bottling machinery - Agitators: pure liquids	0.8 to 1.25	1 to 1.5	1.25 to 1.75
		Propellers - Waterjet pumps	1.25	1.5	1.75
	MODERATE SHOCKS	Blowers: lobe - Pumps: gear and lobe types - Vane compressors - Machine tools: main drives - Conveyors: belt & chain not uniformly fed bucket & screw - Elevators, cranes, tackles & winches - Wire winding machines, reels, winders (paper industry) - Agitators: liquids and solids, liquids of variable density	1.25 to 1.5	1.5 to 1.75	1.75 to 2
	HEAVY SHOCKS	Generators (welding) - Reciprocating pumps & compressors - Laundry washers - Bending roll, punch press, tapping machines - Barkers, calenders, paper presses - Briquetter machines, cement furnace - Crushers: ore & stone, hammer mill, rubber mill - Metal mills: forming machines, table conveyors - Draw bench, wire-drawing & flattening machines - Road & railroad equipment	1.5 to 2	1.75 to 2.25	2 to 2.5

1) Maximum misalignment

Table 2: CST

CST size	Tn Ref kNm	Tn Ref \odot kNm	n Ref min ⁻¹
30	0,55	0,275	16 000
40	1,10	0,55	13 800
55	1,97	0,985	10 200
65	3,24	1,62	8 660
80	5,60	2,80	6 900
100	8,50	4,25	6 000

Table 3: CST...M / CST...N

CST...M size	Tn Ref kNm	Tn Ref \odot kNm	n Ref min ⁻¹
110	16	8	6 050
130	22	11	5 150
155	32	16	4 300
175	45	23	3 950
195	62	31	3 600
215	84	42	3 450
240	115	58	3 300
275	174	87	3 050

CST...N size	Tn Ref kNm	Tn Ref \odot kNm	n Ref min ⁻¹
280	244	122	2 950
320	290	145	2 800
360N	370	185	2 560
400N	450	225	2 290
450N	560	280	2 000

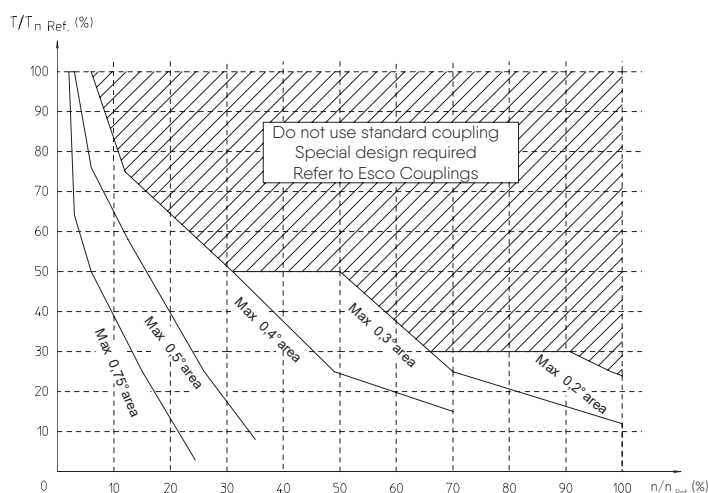
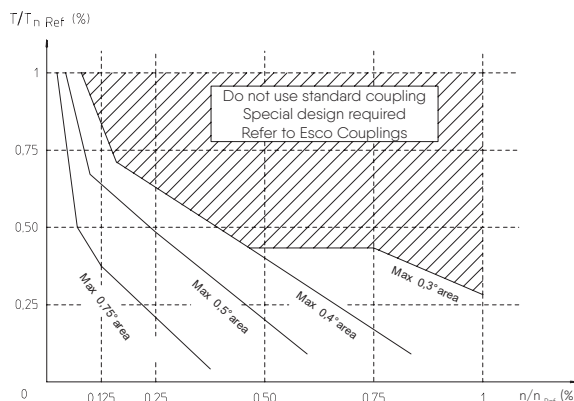

How to use this graph (Tn)?

Maximum torque, maximum speed and maximum misalignment may not occur simultaneously.

1. Calculate Tn (nominal torque) and Tp (peak torque) and select coupling size.
2. Calculate Tn / Tn Ref and n/n Ref and plot the resulting point in the graph.
3. If the resulting point is located in the white area, a standard coupling may be used as far as maximum misalignment does not exceed the minimum misalignment indicated in the graph.
4. If the resulting point is located in the shaded area, please refer to ESCO Couplings.
5. In case of use in potentially explosive atmospheres \odot , proceed with the same way but using Tn Ref \odot for the calculation. Maximum misalignment may not exceed 0.5° per gear mesh.

2) Minimum misalignment:

To ensure proper gear lubrication = $\Delta K_w \min = 0.1^\circ$

3) Misalignment control:

- a) Measure X (Total Indicator Readout - TIR)
- b) Measure Y - Z
- c) Verify the relationship for the misalignment control:

$$\Delta K_w \min \leq \frac{X}{K_x} + \frac{Y - Z}{K_y} \leq 0.75 \times \Delta K_w \max$$

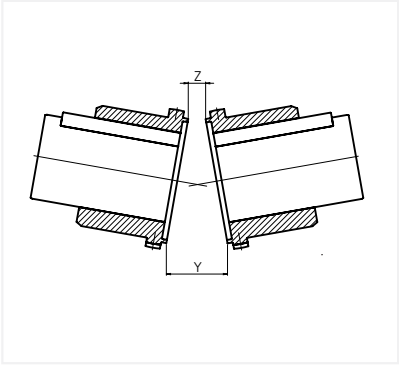
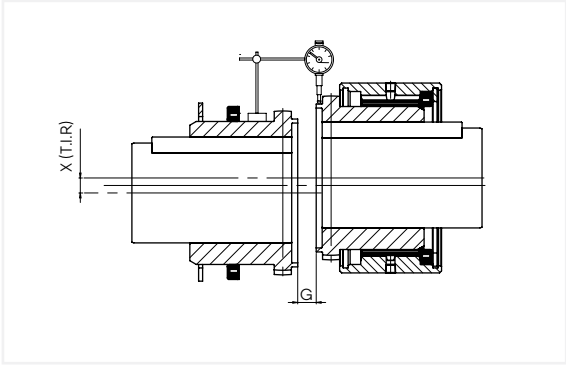

4) Examples:

- Example of calculation:
 $\left. \begin{matrix} T/Tn \text{ ref} = 30\% \\ n/n \text{ ref} = 30\% \end{matrix} \right\} \Delta K_w \max = 0.4^\circ$
 CST...M 175: $K_x = 5.72$ $K_y = 8.2$
- Example of measurement:
 $X \text{ (TIR)} = 0.9 \text{ mm}$ $Y - Z = 0.4 \text{ mm}$

- Example of control:
 Formula: $\Delta K_w \min \leq \frac{X}{K_x} + \frac{Y - Z}{K_y} \leq 0.75 \times \Delta K_w \max$
 Calculation: $0.1^\circ \leq \frac{0.9}{5.7} + \frac{0.4}{8.2} \leq 0.75 \times 0.4$

CST	K_{x0}	K_{y0}
30	0.55	1.78
40	0.78	2.11
55	0.71	2.88
65	1.00	3.49
80	1.19	4.22
100	1.25	4.99

CST...M	K_{x0}	K_{y0}
110	3.80	5.28
130	4.47	6.22
155	5.03	7.55
175	5.72	8.20
195	6.35	9.18
215	7.47	9.98
240	8.24	11.04
275	9.18	12.98

CST...N	K_{x0}	K_{y0}
280	10.82	13.76
320	11.34	15.08
360N	12.32	16.76
400N	13.37	18.50
450N	14.35	20.74

Notes:

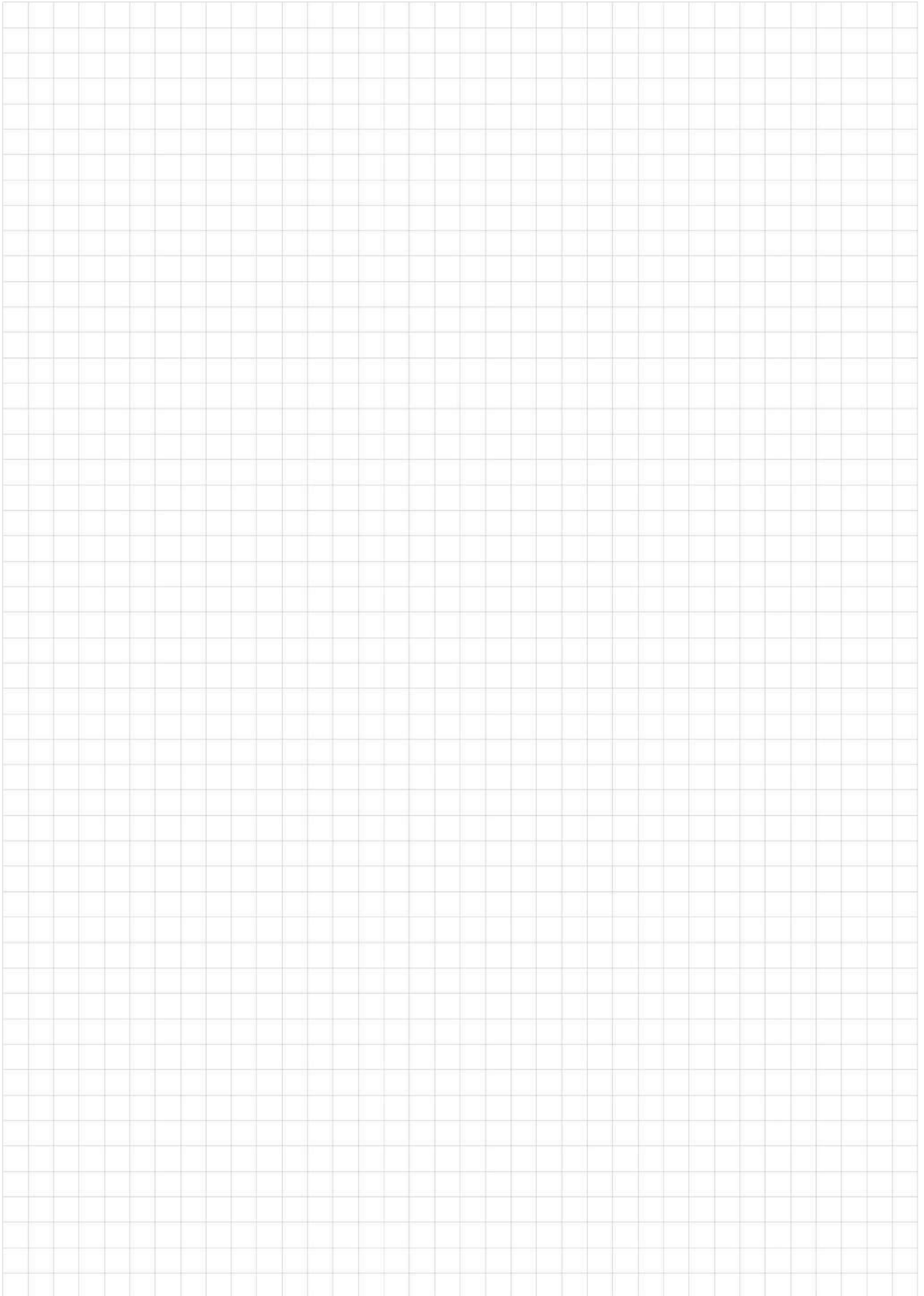

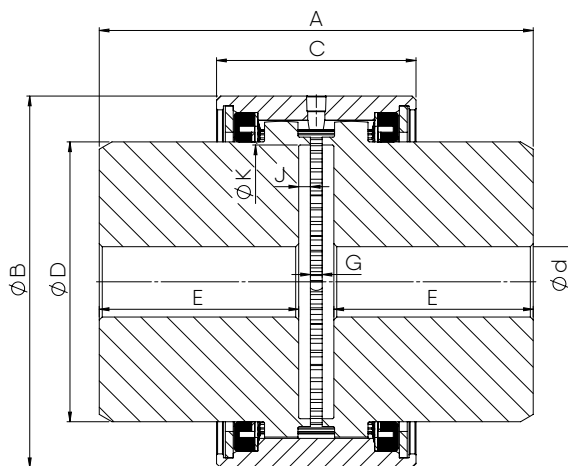

size	torque CST		torque CSU (1)		n1 max.	n2 max. (2)	Ød min. (3)	Ød max. (4)	A	ØB	C	ØD	E	G	J	K	weight (5)	inertia J (5)	max. misalignment		
	nominal Tn	peak Tp	nominal Tn	peak Tp															angular	radial	axial ±
CST CSU	kNm	kNm	kNm	kNm	rpm	rpm	dimensions in mm										kg	kgm²	degree	mm	mm
30	0.55	1.1	1.1	2.2	5 500	7 750	0	35	80	84	50	50.9	38.5	3	3	49	2.2	0.002	2x0.75	0.2	3
40	1.1	2.2	2.2	4.4	5 100	7 200	0	42	95	95	65	60.4	46	3	5	57	3.5	0.004	2x0.75	0.3	3
55	1.97	3.94	3.94	7.88	4 400	6 200	22	63	110	120	68	82.6	53.5	3	5	76	6.2	0.010	2x0.75	0.3	3
65	3.24	6.48	6.48	12.96	4 000	5 600	25	75	120	140	80	100	57	6	6	95	9.6	0.022	2x0.75	0.4	6
80	5.6	11.2	11.2	22.4	3 600	5 100	38	90	140	168	95	121	67	6	6	121	16	0.053	2x0.75	0.5	6
100	8.5	17	17	34	3 400	4 800	38	110	222	190	102	143	108	6	6	140	31	0.118	2x0.75	0.5	6

- (1) Up-rated torque execution
- (2) Special balancing recommended and use of high speed grease
- (3) Min. finish machine bore diameter (size ≥ 55)
- (4) Max. bore diameter with one keyway acc. DIN 6885/1
- (5) For pre-bored/unbored hubs

- Couplings can be supplied with several options (e.g. puller holes, set screws, ATEX, surface protection)
→ refer to page 43 et seqq. (B404a et seqq.)
- For the correct coupling selection please refer to page 16 et seqq. (A150a)
- For special executions or requirements, please contact us
- Technical modifications reserved and given values without engagement

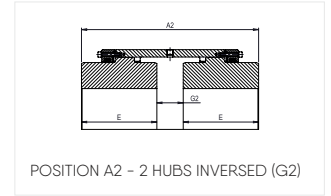
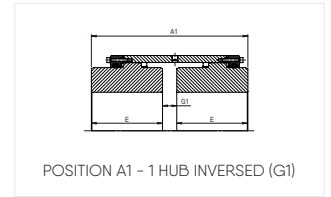
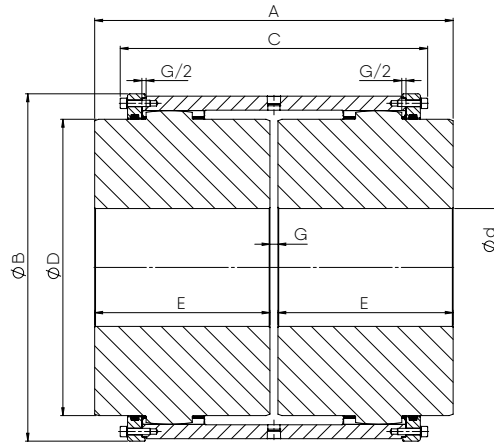
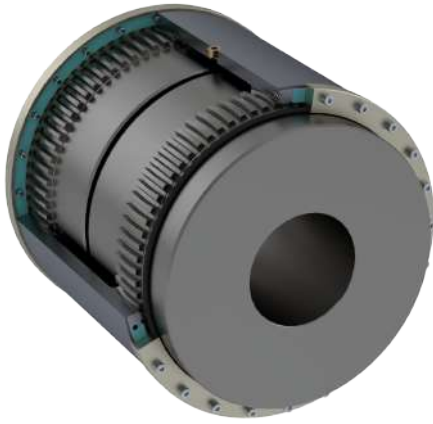

size	torque CST...M		torque CSU...M (1)		n1 max.	n2 max. (2)	Ød min. (3)	Ød max. (4)	A	A1	A2	ØB	C	ØD	E	G	G1	G2	weight (5)	inertia J (5)	max. misalignment			
	nominal Tn	peak Tp	nominal Tn	peak Tp																	angular	radial	axial ±	
CST...M CSU...M	kNm	kNm	kNm	kNm	rpm	rpm	dimensions in mm													kg	kgm²	degree	mm	mm
110M	16	32	32	64	3 350	4 700	0	112	185	199	213	186	177	151	90	5	19	33	34	0.139	2x 0.75	1.4	5	
130M	22	44	44	88	3 100	4 350	55	132	216	233	250	216	209	178	105	6	23	40	51	0.304	2x 0.75	1.6	6	
155M	32	64	64	128	2 800	4 000	65	158	246	264	282	254	230	213	120	6	24	42	81	0.652	2x 0.75	1.8	6	
175M	45	90	90	180	2 700	3 800	80	175	278	299	320	282	257	235	135	8	29	50	111	1.13	2x 0.75	2.0	8	
195M	62	124	124	248	2 550	3 600	90	198	308	332	356	317	279	263	150	8	32	56	153	1.96	2x 0.75	2.4	8	
215M	84	168	168	336	2 450	3 450	100	217	358	389	420	346	322	286	175	8	39	70	207	3.09	2x 0.75	2.8	8	
240M	115	230	230	460	2 300	3 300	120	244	388	426	464	376	349	316	190	8	46	84	262	4.74	2x 0.75	3.0	8	
275M	174	348	348	696	2 150	3 050	150	290	450	483	516	436	386	372	220	10	43	76	398	9.76	2x 0.75	3.4	10	

- (1) Up-rated torque execution
- (2) Special balancing recommended and use of high speed grease
- (3) Min. finish machine bore diameter (size ≥ 130)
- (4) Max. bore diameter with one keyway acc. DIN 6885/1
- (5) For pre-bored/unbored hubs

- Couplings can be supplied with several options (e.g. puller holes, set screws, ATEX, Viton O-Ring, surface protection) → refer to page 43 et seqq. (B404a et seqq.)
- For the correct coupling selection please refer to page 16 et seqq. (A150a)
- For special executions or requirements, please contact us
- Technical modifications reserved and given values without engagement

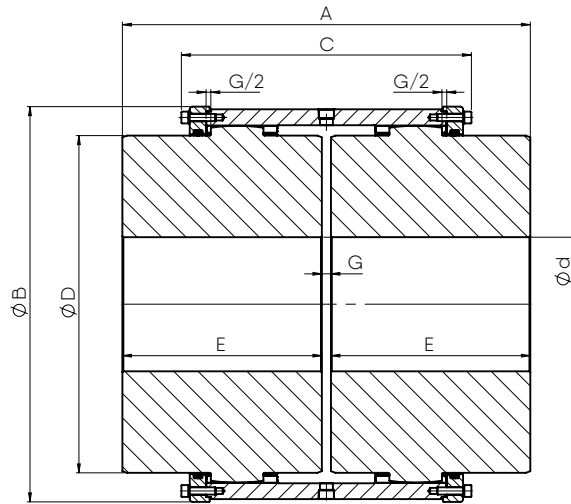

size	torque CSS...M		torque CSUSS...M (1)		n1 max.	n2 max. (2)	Ød min. (3)	Ød max. (4)	A	ØB	C	ØD	E	G	weight (5)	Inertia J (5)	max. misalignment		
	nominal T _n	peak T _p	nominal T _n	peak T _p													angular	radial	axial (±)
CSS...M/ CSUSS...M	kNm	kNm	kNm	kNm	rpm	rpm	dimensions in mm								kg	kgm ²	degree	mm	mm
110M	16	32	32	64	3 350	4 700	0	112	185	186	146	151	90	5	33	0.130	2x0.75	0.5	5
130M	22	44	44	88	3 100	4 350	55	132	216	216	172	178	105	6	49	0.280	2x0.75	0.6	6
155M	32	64	64	128	2 800	4 000	65	158	246	254	191	213	120	6	75	0.610	2x0.75	0.7	6
175M	45	90	90	180	2 700	3 800	80	175	278	282	212	235	135	8	107	1.05	2x0.75	0.8	8
195M	62	124	124	248	2 550	3 600	90	198	308	317	228	263	150	8	147	1.82	2x0.75	0.9	8
215M	84	168	168	336	2 450	3 450	100	217	358	346	257	286	175	8	198	2.87	2x0.75	1.0	8
240M	115	230	230	460	2 300	3 300	120	244	388	376	280	316	190	8	253	4.43	2x0.75	1.0	8
275M	174	348	348	696	2 150	3 050	150	290	450	436	317	372	220	10	383	9.26	2x0.75	1.3	10

- (1) Up-rated torque execution
- (2) Special balancing recommended and use of high speed grease
- (3) Min. finish machine bore diameter (size ≥ 130)
- (4) Max. bore diameter with one keyway acc. DIN 6885/1
- (5) For pre-bored/unbored hubs

- Couplings can be supplied with several options (e.g. puller holes, set screws, ATEX, Viton O-Ring, surface protection)
→ refer to page 43 et seqq. (B404a et seqq.)
- For the correct coupling selection please refer to page 16 et seqq. (A150a)
- For special executions or requirements, please contact us
- Technical modifications reserved and given values without engagement

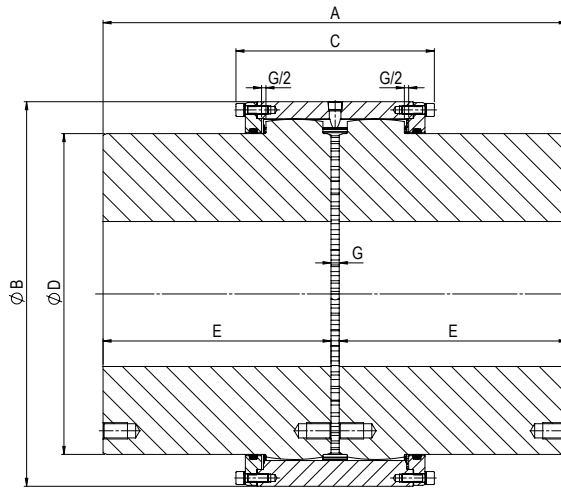
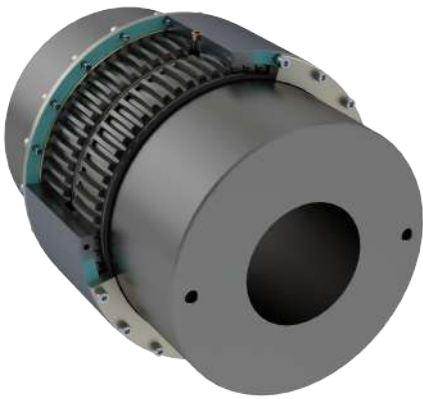

size	torque CST...N		torque CSU...N (1)		n1 max.	Ød min. (2)	Ød max. (3)	A	ØB	C	ØD	E	G	weight (4)	inertia J (4)	max. misalignment		
	nominal Tn	peak Tp	nominal Tn	peak Tp												angular	radial	axial ±
CST...N CSU...N	kNm	kNm	kNm	kNm	rpm	dimensions in mm								kg	kgm ²	degree	mm	mm
280N	244	488	488	976	1900	180	310	570	472	244	394	280	10	544	16	2X0.75	3.6	10
320N	290	580	580	1160	1800	200	340	597	518	250	432	292	13	684	24	2X0.75	3.8	13
360N	370	740	740	1480	1500	220	375	623	562	265	480	305	13	838	35	2X0.75	3.8	13
400N	450	900	900	1800	1400	260	420	673	620	270	530	330	13	1074	55	2X0.75	4.0	13
450N	560	1120	1120	2240	1300	280	470	713	682	270	594	350	13	1412	87	2X0.75	4.2	13

- (1) Up-rated torque execution
- (2) Min. finish machine bore diameter
- (3) Max. bore diameter with one keyway acc. DIN 6885/1
- (4) For pre-bored/unbored hubs

- Couplings can be supplied with several options (e.g. puller holes, set screws, ATEX, Viton O-Ring, surface protection)
 → refer to page 43 et seqq. (B404a et seqq.)
- For the correct coupling selection please refer to page 16 et seqq. (A150a)
- For special executions or requirements, please contact us
- Technical modifications reserved and given values without engagement

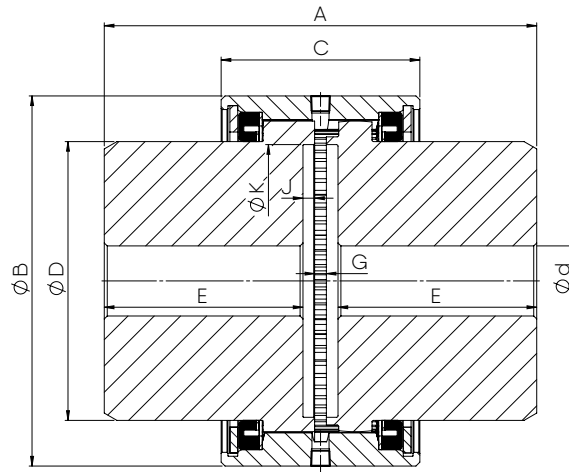

size	torque CFS		torque CSUFS (1)		n1 max.	n2 max. (2)	Ød min. (3)	Ød max. (4)	A	ØB	C	ØD	E	G	J	K	weight (5)	inertia J (5)	max. misalignment		
	nominal T _n	peak T _p	nominal T _n	peak T _p															angular	radial	axial ±
CFS CSUFS	kNm	kNm	kNm	kNm	rpm	rpm	dimensions in mm										kg	kgm ²	degree	mm	mm
30	0.55	1.10	1.10	2.20	5 500	7 750	0	35	80	84	50	50.9	38.5	3	3	49	2.2	0.002	0.75	0.2	3
40	1.10	2.20	2.20	4.4	5 100	7 200	0	42	95	95	65	60.4	46	3	5	57	3.6	0.004	0.75	0.3	3
55	1.97	3.94	3.94	7.9	4 400	6 200	22	63	110	120	68	82.6	53.5	3	5	76	6.2	0.010	0.75	0.3	3
65	3.24	6.5	6.5	13.0	4 000	5 600	25	75	120	140	80	100	57	6	6	95	9.1	0.022	0.75	0.4	6
80	5.6	11.2	11.2	22.4	3 600	5 100	38	90	140	168	95	121	67	6	6	121	15	0.052	0.75	0.5	6
100	8.5	17	17	34	3 400	4 800	38	110	222	190	102	143	108	6	6	140	31	0.119	0.75	0.5	6

- (1) Up-rated torque execution
- (2) Special balancing recommended and use of high speed grease
- (3) Min. finish machine bore diameter (size ≥ 55)
- (4) Max. bore diameter with one keyway acc. DIN 6885/1
- (5) For pre-bored/unbored hubs

- Couplings can be supplied with several options (e.g. puller holes, set screws, ATEX, Viton O-Ring, surface protection) → refer to page 43 et seqq. (B404a et seqq.)
- For the correct coupling selection please refer to page 16 et seqq. (A150a)
- For special executions or requirements, please contact us
- Technical modifications reserved and given values without engagement

CFS...M/CSUFS...M
FLOATING SHAFT
 110M ➤ 275M

B3111a

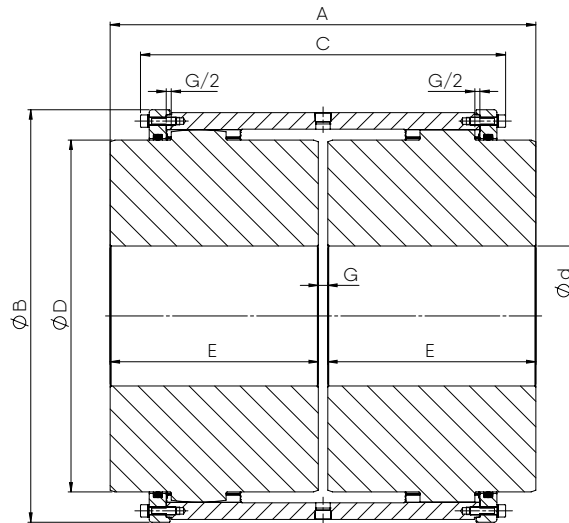
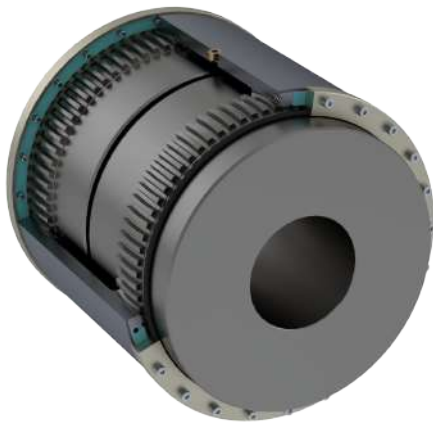

size	torque CFS...M		torque CSUFS...M (1)		n1 max.	n2 max. (2)	Ød min. (3)	Ød max. (4)	A	ØB	C	ØD	E	G	weight (5)	inertia J (5)	max. misalignment		
	nominal T _n	peak T _p	nominal T _n	peak T _p													angular	radial	axial ±
CFS...M CSUFS...M	kNm	kNm	kNm	kNm	rpm	rpm	dimensions in mm								kg	kgm ²	degree	mm	mm
110M	16	32	32	64	3 350	4 700	0	112	185	186	177	151	90	5	34	0.139	0.75	1.4	5
130M	22	44	44	88	3 100	4 350	55	132	216	216	209	178	105	6	51	0.304	0.75	1.6	6
155M	32	64	64	128	2 800	4 000	65	158	246	254	230	213	120	6	81	0.652	0.75	1.8	6
175M	45	90	90	180	2 700	3 800	80	175	278	282	257	235	135	8	111	1.13	0.75	2.0	8
195M	62	124	124	248	2 550	3 600	90	198	308	317	279	263	150	8	153	1.96	0.75	2.4	8
215M	84	168	168	336	2 450	3 450	100	217	358	346	322	286	175	8	207	3.09	0.75	2.8	8
240M	115	230	230	460	2 300	3 300	120	244	388	376	349	316	190	8	262	4.74	0.75	3.0	8
275M	174	348	348	696	2 150	3 050	150	290	450	436	386	372	220	10	398	9.76	0.75	3.4	10

- (1) Up-rated torque execution
- (2) Special balancing recommended and use of high speed grease
- (3) Min. finish machine bore diameter (size ≥ 130)
- (4) Max. bore diameter with one keyway acc. DIN 6885/1
- (5) For pre-bored/unbored hubs

- Couplings can be supplied with several options (e.g. puller holes, set screws, ATEX, Viton O-Ring, surface protection)
→ refer to page 43 et seqq. (B404a et seqq.)
- For the correct coupling selection please refer to page 16 et seqq. (A150a)
- For special executions or requirements, please contact us
- Technical modifications reserved and given values without engagement

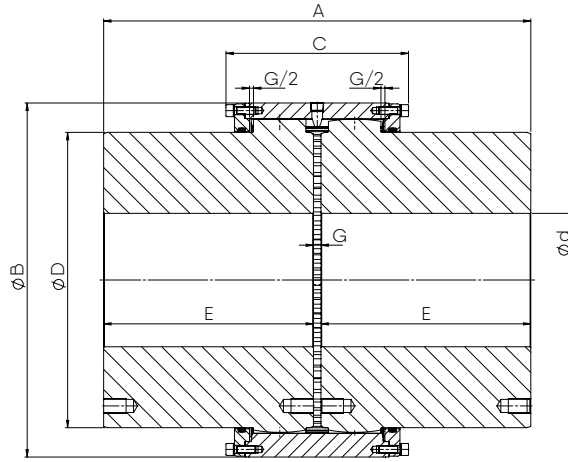
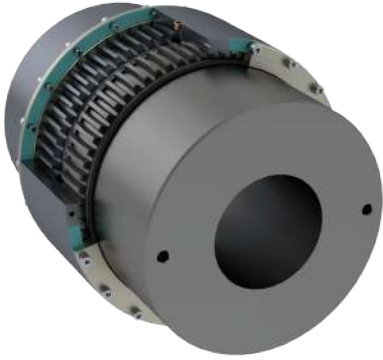

size	torque CFS...N		torque CSUFS...N (1)		n1 max.	$\varnothing d$ min. (2)	$\varnothing d$ max. (3)	A	$\varnothing B$	C	$\varnothing D$	E	G	weight (4)	inertia J (4)	max. misalignment		
	nominal Tn	peak Tp	nominal Tn	peak Tp												angular	radial	axial ±
CFS...N CSUFS...N	kNm	kNm	kNm	kNm	rpm	dimensions in mm							kg	kgm ²	degree	mm	mm	
280N	244	488	488	976	1900	180	310	570	472	244	394	280	10	544	15.8	0.75	3.6	10
320N	290	580	580	1160	1800	200	340	597	518	250	432	292	13	684	24.0	0.75	3.8	13
360N	370	740	740	1480	1500	220	375	623	562	265	480	305	13	838	34.6	0.75	3.8	13
400N	450	900	900	1800	1400	260	420	673	620	270	530	330	13	1074	55.0	0.75	4.0	13
450N	560	1120	1120	2240	1300	280	470	713	682	270	594	350	13	1412	87.0	0.75	4.2	13

- (1) Up-rated torque execution
- (2) Min. finish machine bore diameter
- (3) Max. bore diameter with one keyway acc. DIN 6885/1
- (4) For pre-bored/unbored hubs

- Couplings can be supplied with several options (e.g. puller holes, set screws, ATEX, Viton O-Ring, surface protection)
→ refer to page 43 et seqq. (B404a et seqq.)
- For the correct coupling selection please refer to page 16 et seqq. (A150a)
- For special executions or requirements, please contact us
- Technical modifications reserved and given values without engagement

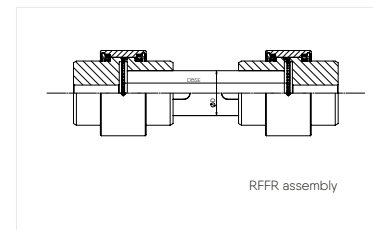
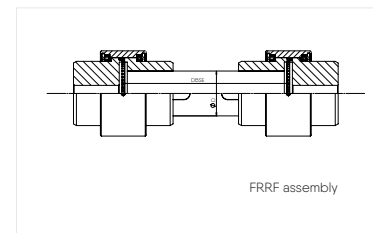
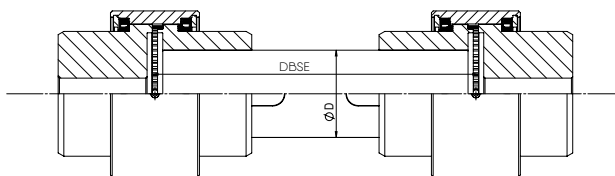

Size	ØD (1)	Max. speed function DBSE									
		600	800	1 000	1 500	2 000	3 000	4 000	5 000	6 000	7 000
CFS CSUFS	dimensions mm										
30	27	7 750	4 753	2 915	1 255	671	290				
40	41	7 200	7 506	4 563	1 898	1 033	445				
55	51	6 200	6 200	5 882	2 415	1 307	560	309			
65	65	5 600	5 600	5 600	3 105	1 677	716	395	250		
80	76	5 100	5 100	5 100	3 737	2 003	849	467	295	203	
100	85	4 800	4 800	4 800	4 731	2 451	1 006	545	341	233	

(1) Diameter D, based on double keyway transmissions, can be adapted depending on application data

- Couplings can be supplied with several options (e.g. puller holes, set screws, ATEX, Viton O-Ring, surface protection)
→ refer to page 43 et seqq. (B404a et seqq.)
- For the correct coupling selection please refer to page 16 et seqq. (A150a)
- For special executions or requirements, please contact us
- Technical modifications reserved and given values without engagement

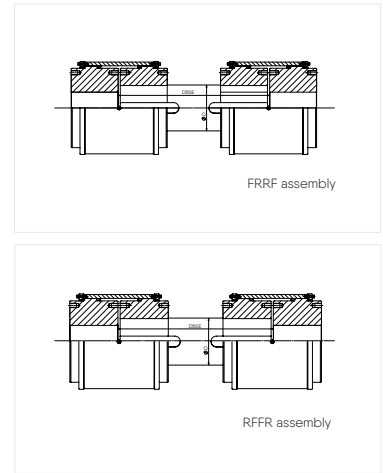
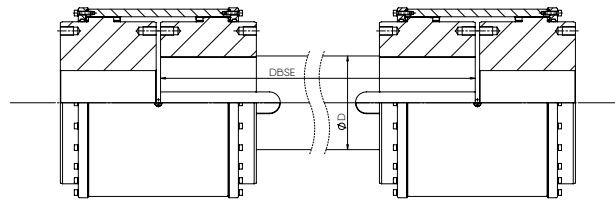
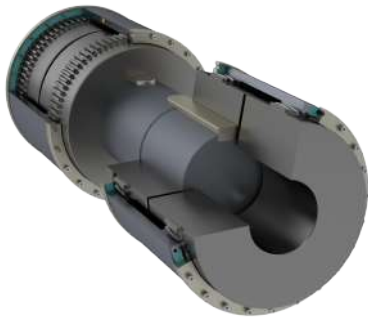

Size	ØD (1)	Max. speed function DBSE										
		600	800	1 000	1 500	2 000	3 000	4 000	5 000	6 000	7 000	
CFS...M CSUFS...M	dimensions mm											
110M	109	4 700	4 700	4 700	4 700	2 967	1 244	680				
130M	121	4 350	4 350	4 350	4 350	3 412	1 412	767				
155M	137	4 000	4 000	4 000	4 000	3 959	1 624	879	550			
175M	153	3 800	3 800	3 800	3 800	3 800	1 846	994	620			
195M	171	3 600	3 600	3 600	3 600	3 600	2 096	1 124	700			
215M	189	3 450	3 450	3 450	3 450	3 450	2 386	1 270	786	535		
240M	210	3 300	3 300	3 300	3 300	3 300	2 703	1 431	884	599		
275M	240	3 050	3 050	3 050	3 050	3 050	3 050	1 669	1 026	694	501	

(1) Diameter D, based on double keyway transmissions, can be adapted depending on application data

- Couplings can be supplied with several options (e.g. puller holes, set screws, ATEX, Viton O-Ring, surface protection)
→ refer to page 43 et seqq. (B404a et seqq.)
- For the correct coupling selection please refer to page 16 et seqq. (A150a)
- For special executions or requirements, please contact us
- Technical modifications reserved and given values without engagement

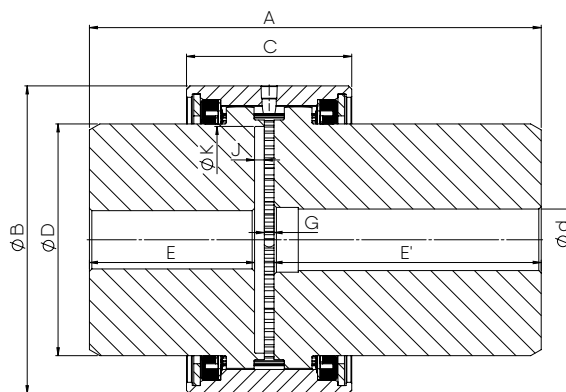

size	torque CMM		torque CSUMM (1)		n1 max.	n2 max. (2)	Ød min. (3)	Ød max. (4)	A	ØB	C	ØD	E	E'	G	J	ØK	weight (5)	inertia J (5)	max. misalignment		
	nominal T _n	peak T _p	nominal T _n	peak T _p																angular	radial	axial ±
CMM CSUMM	kNm	kNm	kNm	kNm	rpm	rpm	dimensions in mm											kg	kgm ²	degree	mm	mm
30	0.55	1.1	1.1	2.2	5 500	7 750	0	32	136.7	84	50	50.9	38.5	95.2	3	3	49	2.8	0.002	2x0.75	0.2	3
40	1.1	2.2	2.2	4.4	5 100	7 200	0	42	150	95	65	60.4	46	101	3	5	57	4.5	0.004	2x0.75	0.3	3
55	1.97	3.94	3.94	7.88	4 400	6 200	22	63	174	120	68	82.6	53.5	117.5	3	5	76	9.2	0.013	2x0.75	0.3	3
65	3.24	6.48	6.48	12.96	4 000	5 600	25	75	193	140	80	100	57	130	6	6	95	15	0.028	2x0.75	0.4	6
80	5.6	11.2	11.2	22.4	3 600	5 100	38	90	219	168	95	121	67	146	6	6	121	21	0.065	2x0.75	0.5	6
100	8.5	17	17	34	3 400	4 800	38	110	279	190	102	143	108	165	6	6	140	38	0.138	2x0.75	0.5	6

- (1) Up-rated torque execution
- (2) Special balancing recommended and use of high speed grease
- (3) Min. finish machine bore diameter (size ≥ 55)
- (4) Max. bore diameter with one keyway acc. DIN 6885/1
- (5) For pre-bored/unbored hubs

- Couplings can be supplied with several options (e.g. puller holes, set screws, ATEX, surface protection)
→ refer to page 43 et seqq. (B404a et seqq.)
- For the correct coupling selection please refer to page 16 et seqq. (A150a)
- For special executions or requirements, please contact us
- Technical modifications reserved and given values without engagement

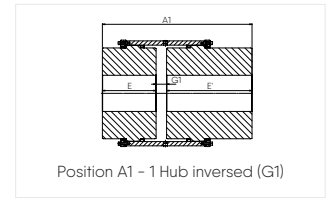
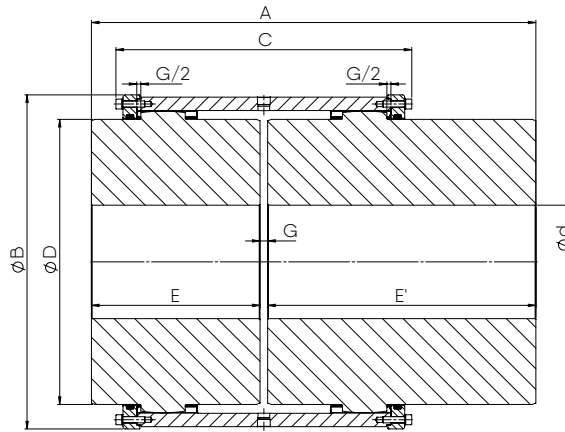
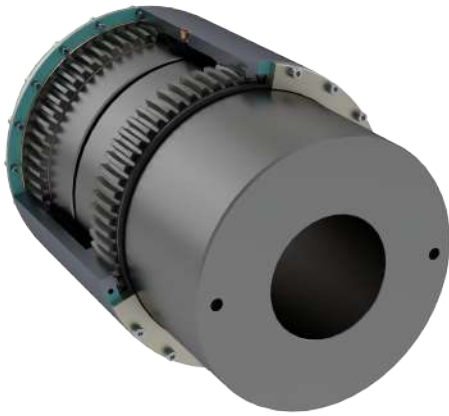

size	torque CMM...M		torque CSUMM...M (1)		n1 max.	n2 max. (2)	Ød min. (3)	Ød max. (4)	A	A1	ØB	C	ØD	E	E'	G	G1	weight (5)	inertia J (5)	max. misalignment		
	nominal Tn	peak Tp	nominal Tn	peak Tp																angular	radial	axial ±
CMM...M CSUMM...M	kNm	kNm	kNm	kNm	rpm	rpm	dimensions in mm											kg	kgm²	degree	mm	mm
110M	16	32	32	64	3 350	4 700	0	112	260	274	186	177	151	90	165	5	19	45	0.169	2x0.75	1.4	5
130M	22	44	44	88	3 100	4 350	55	132	281	298	216	209	178	105	170	6	23	63	0.354	2x0.75	1.6	6
155M	32	64	64	128	2 800	4 000	65	158	316	334	254	230	213	120	190	6	24	99	0.845	2x0.75	1.8	6
175M	45	90	90	180	2 700	3 800	80	175	343	364	282	257	235	135	200	8	29	130	1.28	2x0.75	2.0	8
195M	62	124	124	248	2 550	3 600	90	198	378	402	317	279	263	150	220	8	32	179	2.21	2x0.75	2.4	8
215M	84	168	168	336	2 450	3 450	100	217	433	464	346	322	286	175	250	8	39	240	3.47	2x0.75	2.8	8
240M	115	230	230	460	2 300	3 300	120	244	478	516	376	349	316	190	280	8	46	310	5.42	2x0.75	3.0	8
275M	174	348	348	696	2 150	3 050	150	290	580	613	436	386	372	220	350	10	43	491	13.0	2x0.75	3.4	10

- (1) Up-rated torque execution
- (2) Special balancing recommended and use of high speed grease
- (3) Min. finish machine bore diameter (size ≥ 130)
- (4) Max. bore diameter with one keyway acc. DIN 6885/1
- (5) For pre-bored/unbored hubs

- Couplings can be supplied with several options (e.g. puller holes, set screws, ATEX, Viton O-Ring, surface protection) → refer to page 43 et seqq. (B404a et seqq.)
- For the correct coupling selection please refer to page 16 et seqq. (A150a)
- For special executions or requirements, please contact us
- Technical modifications reserved and given values without engagement

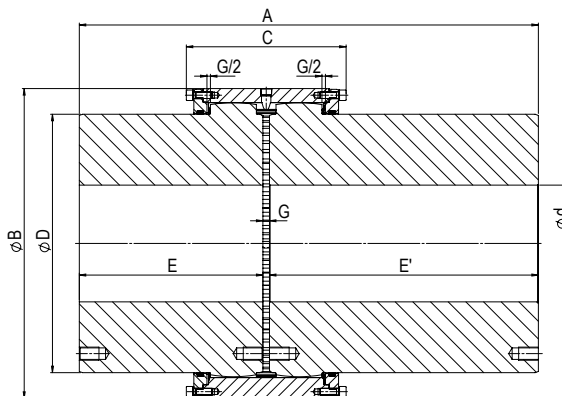
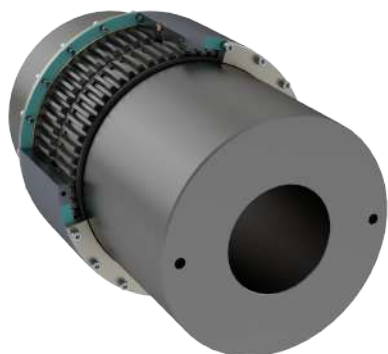

size	torque CMM...N		torque CSUMM...N (1)		n1 max.	Ød min. (2)	Ød max. (3)	A	ØB	C	ØD	E	E'	G	weight (4)	inertia J (4)	max. misalignment			
	nominal T _n	peak T _p	nominal T _n	peak T _p													angular	radial	axial ±	
CMM...N CSUMM...N	kNm	kNm	kNm	kNm	rpm	dimensions in mm										kg	kgm ²	degree	mm	mm
280N	244	488	488	976	1900	180	310	700	472	244	394	280	410	10	627	17.7	2x0.75	3.6	10	
320N	290	580	580	1160	1800	200	340	775	518	250	432	292	470	13	827	28.1	2x0.75	3.8	13	
360N	370	740	740	1480	1500	220	375	788	562	262	480	305	470	13	987	39.8	2x0.75	3.8	13	
400N	450	900	900	1800	1400	260	420	893	620	270	530	330	550	13	1317	65	2x0.75	4.0	13	
450N	560	1120	1120	2.240	1300	280	470	913	682	270	594	350	550	13	1670	101	2x0.75	4.2	13	

(1) Up-rated torque execution

(2) Min. finish machine bore diameter

(3) Max. bore diameter with one keyway acc. DIN 6885/1

(4) For pre-bored/unbored hubs

■ Couplings can be supplied with several options (e.g. puller holes, set screws, ATEX, Viton O-Ring, surface protection)
→ refer to page 43 et seqq. (B404a et seqq.)

■ For the correct coupling selection please refer to page 16 et seqq. (A150a)

■ For special executions or requirements, please contact us

■ Technical modifications reserved and given values without engagement

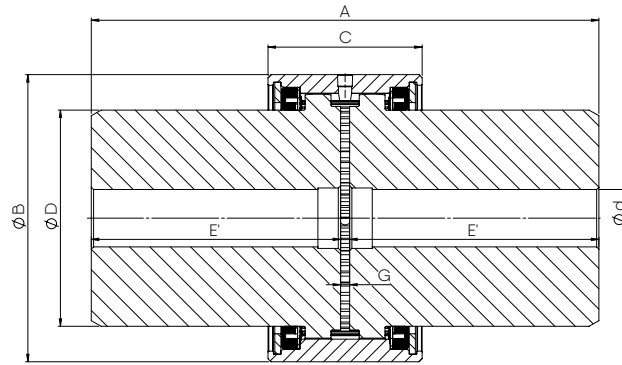

size	torque CDMM		torque CSUDMM (1)		n1 max.	n2 max. (2)	Ød min. (3)	Ød max. (4)	A	ØB	C	ØD	E'	G	weight (5)	Inertia J (5)	max. misalignment		
	nominal T _n	peak T _p	nominal T _n	peak T _p													angular	radial	axial ±
CDMM CSUDMM	kNm	kNm	kNm	kNm	rpm	rpm	dimensions in mm								kg	kgm ²	degree	mm	mm
30	0.55	1.10	1.10	2.20	5 500	7 750	0	35	193	84	50	50.9	95.2	3	3.8	0.003	2x0.75	0.2	3
40	1.10	2.20	2.20	4.4	5 100	7 200	0	42	205	95	65	60.4	101	3	8.5	0.005	2x0.75	0.3	3
55	1.97	3.94	3.94	7.9	4 400	6 200	0	63	238	120	68	82.6	117.5	3	11	0.015	2x0.75	0.3	3
65	3.24	6.48	6.48	13.0	4 000	5 600	0	75	266	140	80	100	130	6	18	0.033	2x0.75	0.4	6
80	5.6	11.2	11.2	22	3 600	5 100	40	90	298	168	95	121	146	6	28	0.078	2x0.75	0.5	6
100	8.5	17	17	34	3 400	4 800	40	110	336	190	102	143	165	6	46	0.158	2x0.75	0.5	6

- (1) Uprated torque execution
- (2) Special balancing recommended and use of high speed grease
- (3) Min. finish machine bore diameter (size ≥ 80)
- (4) Max. bore diameter with one keyway acc. DIN 6885/1
- (5) For pre-bored/unbored hubs

- Couplings can be supplied with several options (e.g. puller holes, set screws, ATEX, surface protection)
→ refer to page 43 et seqq. (B404a et seqq.)
- For the correct coupling selection please refer to page 16 et seqq. (A150a)
- For special executions or requirements, please contact us
- Technical modifications reserved and given values without engagement

CDMM...M/CSUDMM...M
DOUBLE MILL MOTOR
 110M ➤ 275M

B3131a

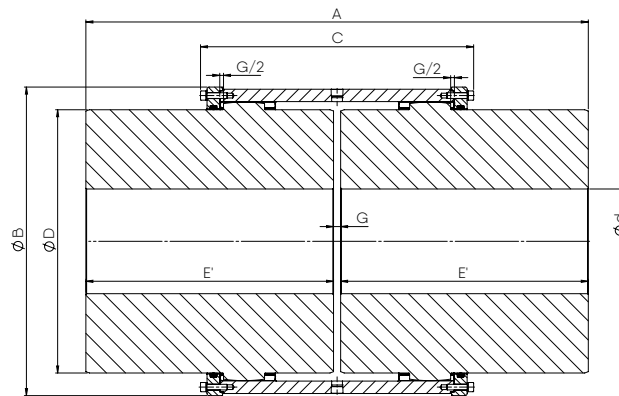

size	torque CDMM...M		torque CSUDMM...M (1)		n1 max.	n2 max. (2)	Ød min. (3)	Ød max. (4)	A	ØB	C	ØD	E'	G	weight (5)	Inertia J (5)	max. misalignment		
	nominal T _n	peak T _p	nominal T _n	peak T _p													angular	radial	axial ±
CDMM...M CSUDMM...M	kNm	kNm	kNm	kNm	rpm	rpm	dimensions in mm								kg	kgm ²	degree	mm	mm
110M	16	32	32	64	3 350	4 700	0	112	335	186	177	151	165	5	55	0.199	2x0.75	1.4	5
130M	22	44	44	88	3 100	4 350	55	132	346	216	209	178	170	6	75	0.404	2x0.75	1.6	6
155M	32	64	64	128	2 800	4 000	65	158	386	254	230	213	190	6	116	0.873	2x0.75	1.8	6
175M	45	90	90	180	2 700	3 800	80	175	408	282	257	235	200	8	150	1.43	2x0.75	2.0	8
195M	62	124	124	248	2 550	3 600	90	198	448	317	279	263	220	8	206	2.47	2x0.75	2.4	8
215M	84	168	168	336	2 450	3 450	100	217	508	346	322	286	250	8	273	3.85	2x0.75	2.8	8
240M	115	230	230	460	2 300	3 300	120	244	568	376	349	316	280	8	358	6.09	2x0.75	3.0	8
275M	174	348	348	696	2 150	3 050	150	290	710	436	386	372	350	10	585	14	2x0.75	3.4	10

- (1) Up-rated torque execution
- (2) Special balancing recommended and use of high speed grease
- (3) Min. finish machine bore diameter (size ≥ 130)
- (4) Max. bore diameter with one keyway acc. DIN 6885/1
- (5) For pre-bored/unbored hubs

- Couplings can be supplied with several options (e.g. puller holes, set screws, ATEX, Viton O-Ring, surface protection)
→ refer to page 43 et seqq. (B404a et seqq.)
- For the correct coupling selection please refer to page 16 et seqq. (A150a)
- For special executions or requirements, please contact us
- Technical modifications reserved and given values without engagement

CDMM...N/CSUDMM...N
DOUBLE MILL MOTOR
 280N ➤ 450N

B3132a

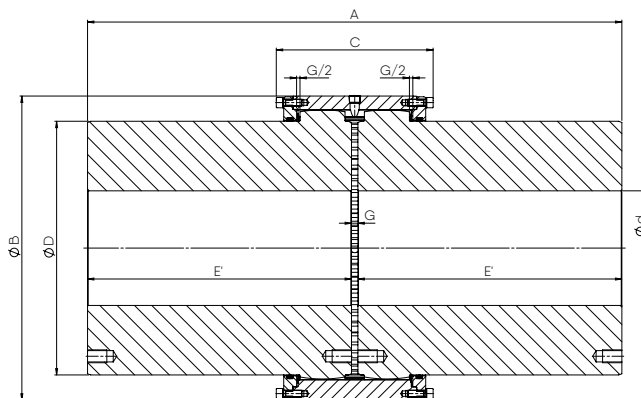
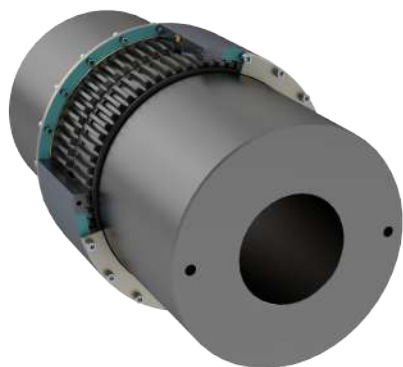

size	torque CDMM...N		torque CSUDMM...N (1)		n max.	Ød min. (2)	Ød max. (3)	A	ØB	C	ØD	E	G	weight (4)	Inertia J (4)	max. misalignment		
	nominal T _n	peak T _p	nominal T _n	peak T _p												angular	radial	axial ±
CDMM...N CSUDMM...N	kNm	kNm	kNm	kNm	rpm	dimensions in mm							kg	kgm ²	degree	mm	mm	
280N	244	488	488	976	1900	180	310	830	472	244	394	410	10	710	19.7	2x0.75	3.6	10
320N	290	580	580	1160	1800	200	340	953	518	250	432	470	13	971	32	2x0.75	3.8	13
360N	370	740	740	1480	1500	220	375	953	562	262	480	470	13	1136	45	2x0.75	3.8	13
400N	450	900	900	1800	1400	260	420	1113	620	270	530	550	13	1559	76	2x0.75	4.0	13
450N	560	1120	1120	2 240	1300	280	470	1113	682	270	594	550	13	1929	114	2x0.75	4.2	13

- (1) Uprated torque execution
- (2) Min. finish machine bore diameter
- (3) Max. bore diameter with one keyway acc. DIN 6885/1
- (4) For pre-bored/unbored hubs

- Couplings can be supplied with several options (e.g. puller holes, set screws, ATEX, Viton O-Ring, surface protection) → refer to page 43 et seqq. (B404a et seqq.)
- For the correct coupling selection please refer to page 16 et seqq. (A150a)
- For special executions or requirements, please contact us
- Technical modifications reserved and given values without engagement

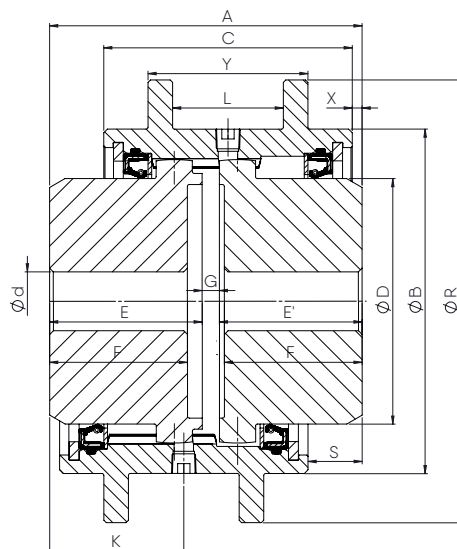
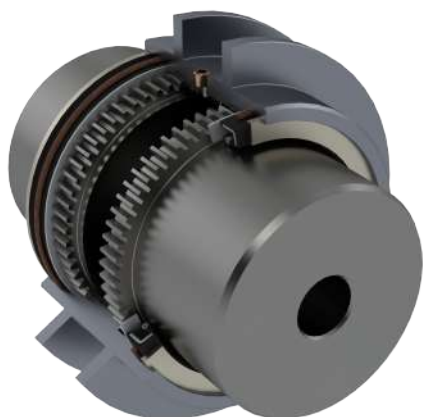

size	torque CCO		torque CSUCO (1)		n max.	Ød min. (2)	Ød max. (3)	A	ØB	C	ØD	E	E'	F	G	K	ØR	L	S	X	Y	weight (4)	inertia J (4)	max. misalignment		
	nominal T _n	peak T _p	nominal T _n	peak T _p																				angular	radial	axial ±
CCO CSUCO	kNm	kNm	kNm	kNm	rpm	dimensions in mm															kg	kgm ²	degree	mm	mm	
30	0.55	1.10	1.10	2.20	4 500	0	32	80	84	68	50	38.5	35.5	35.5	6	35.5	120	30	9.5	0.9	45	3.0	0.004	2x0.5	0.2	3
40	1.10	2.20	2.20	4.40	3 800	0	42	94.8	95	87	60	46	42.8	41	6	39.5	135	35	16	-4.1	55	5.0	0.009	2x0.5	0.3	3
55	1.97	3.94	3.94	7.9	2 750	22	57	110	120	93.5	82	53.5	50.5	48.5	6	47.5	170	40	14	1.4	60	8.5	0.022	2x0.5	0.3	3
65	3.24	6.48	6.48	13.0	2 200	25	70	117	140	101	100	57	53	51	7	50.5	180	45	17.5	-1.5	65	11.4	0.035	2x0.5	0.4	6
80	5.6	11.2	11.2	22.4	1 850	38	85	139	168	111	120	67	61	61	11	60	215	45	19	4.3	70	18.9	0.08	2x0.5	0.5	6
100	8.5	17	17	34	1 600	38	100	222.5	190	125.5	140.5	108	102	102	12.5	101.5	240	50	20.5	37.5	65	34.5	0.16	2x0.5	0.5	6

- (1) Up-rated torque execution
- (2) Min. finish machine bore diameter (size ≥ 55)
- (3) Max. bore diameter with one keyway acc. DIN 6885/1
- (4) For pre-bored/unbored hubs

- Couplings can be supplied with several options (e.g. puller holes, set screws, ATEX, surface protection) → refer to page 43 et seqq. (B404a et seqq.)
- For the correct coupling selection please refer to page 16 et seqq. (A150a)
- For special executions or requirements, please contact us
- Technical modifications reserved and given values without engagement

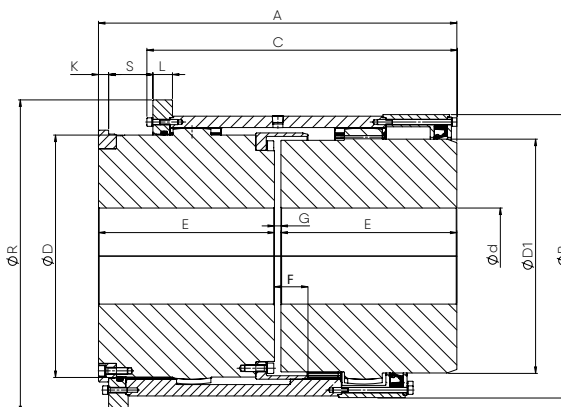

size	torque CCO...M		torque CSUCO...M (1)		n max.	Ød min. (2)	Ød max. (3)	A	ØB	C	ØD	ØD1	E	F	G	K	ØR	L	S	weight (4)	inertia J (4)	max. misalignment			
	nominal T _n	peak T _p	nominal T _n	peak T _p																		angular	radial	axial ±	
CCO...M CSUCO...M	kNm	kNm		kNm	rpm	dimensions in mm															kg	kgm ²	degree	mm	mm
120M	22	44	44	88	1300	55	120	286	216	248	178	165	140	22	6	12	260	22	32	67	0.409	2x0.75	1.6	6	
150M	32	64	64	128	1100	65	150	316	254	275	213	199.5	155	22.5	6	8.5	300	25	37	103	0.858	2x0.75	1.8	6	
165M	45	90	90	180	1000	80	165	358	282	309.5	235	224	175	27	8	12	330	25	42	143	1.59	2x0.75	2.0	8	
185M	62	124	124	248	900	90	185	388	317	333.5	263	250	190	30	8	12	365	25	46	193	1.82	2x0.75	2.4	8	
210M	84	168	168	336	800	100	210	448	346	382	286	280	220	35.5	8	19.5	390	25	53	263	4.28	2x0.75	2.8	8	
230M	115	230	230	460	750	120	230	488	376	417	316	300	240	41.5	8	21	420	25	58	325	5.91	2x0.75	3.0	8	
270M	174	348	348	696	620	150	270	550	435	476.7	372	360	270	39.5	10	23.5	480	30	68	494	13.2	2x0.75	3.4	10	

- (1) Uprated torque execution
- (2) Min. finish machine bore diameter
- (3) Max. bore diameter with one keyway acc. DIN 6885/1
- (4) For pre-bored/unbored hubs

- Couplings can be supplied with several options (e.g. puller holes, set screws, ATEX, Viton O-Ring, surface protection) → refer to page 43 et seqq. (B404a et seqq.)
- For the correct coupling selection please refer to page 16 et seqq. (A150a)
- For special executions or requirements, please contact us
- Technical modifications reserved and given values without engagement

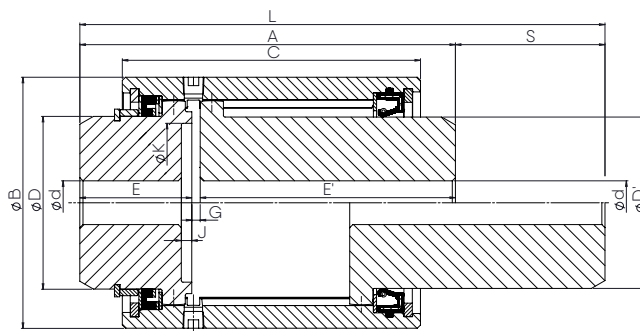

size	torque CSH		torque CSUSH (1)		n max.	Ød min. (2)	Ød max. (3)	A	ØB	C	ØD	ØD'	E	E'	G	J	ØK	L	S	weight (4)	inertia J (4)	max. misalignment			
	nominal T _n	peak T _p	nominal T _n	peak T _p																		angular	radial	axial ±	
CSH CSUSH	kNm	kNm	kNm	kNm	rpm	dimensions mm															kg	kgm ²	degree	mm	mm
30	0.55	1.10	1.10	2.20	5 500	0	32	110	84	83	51	50	38.5	67	4	3	49	140.5	30.5	3.5	0.003	2x0.5	0.2	4	
40	1.10	2.20	2.20	4.40	5 100	0	42	117	95	90.5	60.4	60	46	67	4	5	57	141	24	4.8	0.005	2x0.5	0.3	4	
55	1.97	3.94	3.94	7.9	4 400	22	57	180	120	142.5	82.6	82	53.5	122	4	5	76	251.5	71.4	11.4	0.020	2x0.5	0.3	4	
65	3.24	6.48	6.48	13.0	4 000	25	70	186	140	143.5	100	100	57	125	4.2	6	95	253.5	67.5	15.9	0.036	2x0.5	0.4	4.2	
80	5.6	11.2	11.2	22.4	3 600	38	85	216	168	166.5	121	120	67	145	4.2	6	121	297	81	25.6	0.084	2x0.5	0.5	4.2	
100	8.5	17	17	34	3 400	38	100	263	190	169.5	143	140	108	150	5	6	140	342	79	40.8	0.166	2x0.5	0.5	5	

- (1) Up-rated torque execution
- (2) Min. finish machine bore diameter (size ≥ 55)
- (3) Max. bore diameter with one keyway acc. DIN 6885/1
- (4) For pre-bored/unbored hubs

- Couplings can be supplied with several options (e.g. puller holes, set screws, ATEX, surface protection)
→ refer to page 43 et seqq. (B404a et seqq.)
- For the correct coupling selection please refer to page 16 et seqq. (A150a)
- For special executions or requirements, please contact us
- Technical modifications reserved and given values without engagement

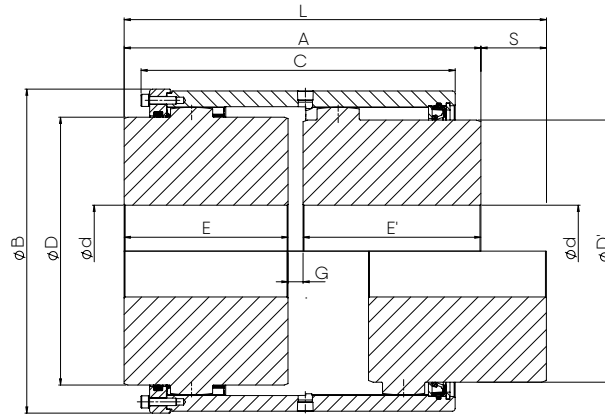

size	torque CSH...M		torque CSUSH...M (1)		n max.	Ød min. (2)	Ød max. (3)	A	ØB	C	ØD	ØD'	E	E'	G min	S	weight (4)	Inertia J (4)	max. misalignment	
	nominal T _n	peak T _p	nominal T _n	peak T _p															angular	axial ±
CSH...M CSUSH...M	kNm	kNm	kNm	kNm	rpm	dimensions mm										kg	kgm ²	degree	mm	
110M	16	32	32	64	3 350	0	112	250	186	248.6	151	140	90	150	10	90	44.9	0.184	2x0.5	5
130M	22	44	44	88	3 100	55	132	276	216	264.6	178	165	105	160	11	85	67.9	0.861	2x0.5	6
155M	32	64	64	128	2 800	65	158	291	254	279.1	213	195	120	160	11	80	107	1.49	2x0.5	6
175M	45	90	90	180	2 700	80	175	319	282	297.6	235	230	135	170	14	75	146	2.58	2x0.5	8
195M	62	124	124	248	2 550	90	198	344	317	306.1	263	260	150	180	14	70	202	4.08	2x0.5	8
215M	84	168	168	336	2 450	100	217	381	346	335.5	286	280	175	190	16	70	215	3.22	2x0.5	8
240M	115	230	230	460	2 300	118	244	406	376	363.8	316	300	190	200	16	81	346	6.16	2x0.5	8
275M	174	348	348	696	2 150	148	290	458	436	404.3	372	340	220	220	18	87	525	12.7	2x0.5	10

- (1) Up-rated torque execution
- (2) Min. finish machine bore diameter (size ≥ 130)
- (3) Max. bore diameter with one keyway acc. DIN 6885/1
- (4) For pre-bored/unbored hubs

- Couplings can be supplied with several options (e.g. puller holes, set screws, ATEX, Viton O-Ring, surface protection) → refer to page 43 et seq. (B404a et seq.)
- For the correct coupling selection please refer to page 16 et seq. (A150a)
- For special executions or requirements, please contact us
- Technical modifications reserved and given values without engagement

Notes:

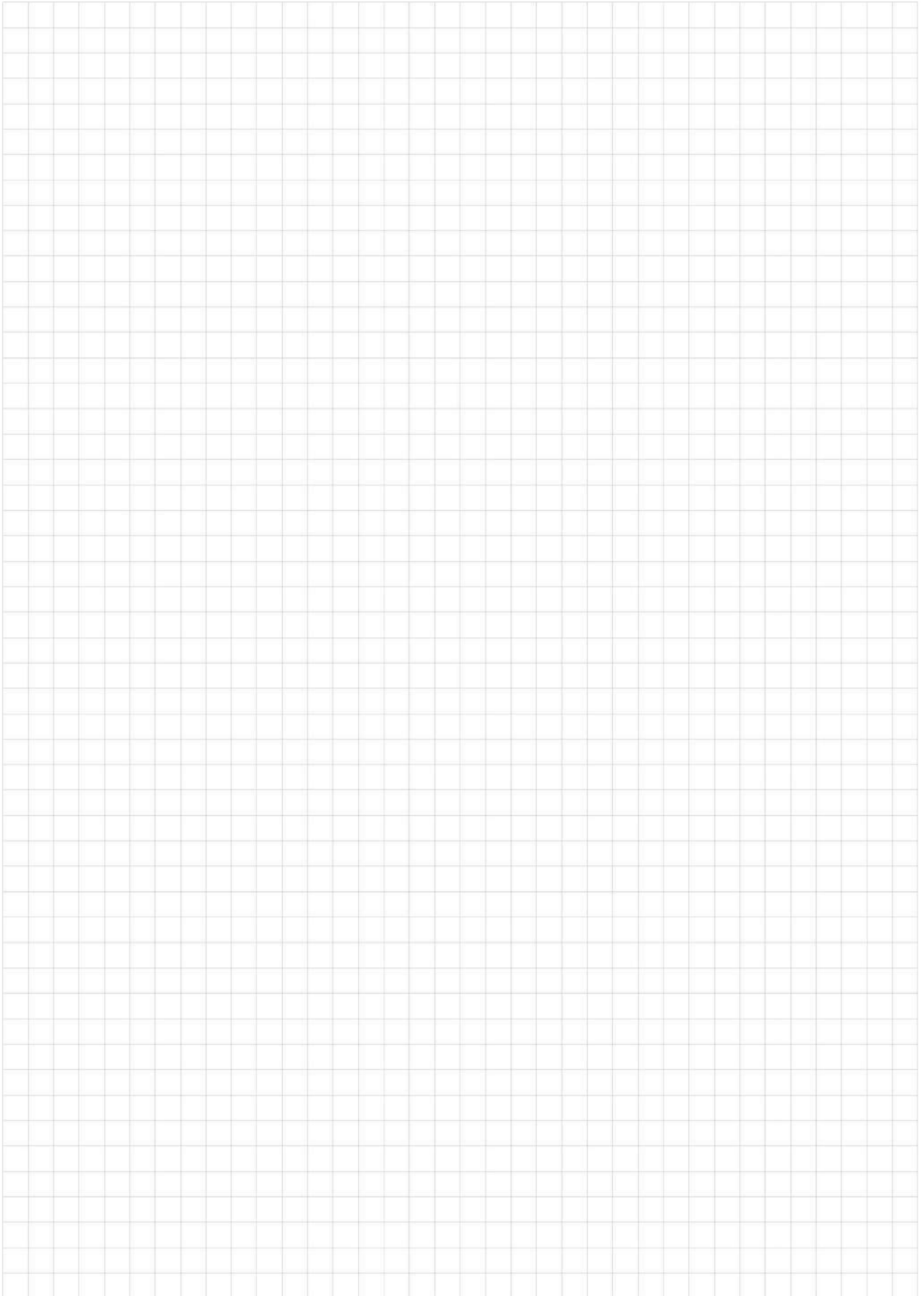

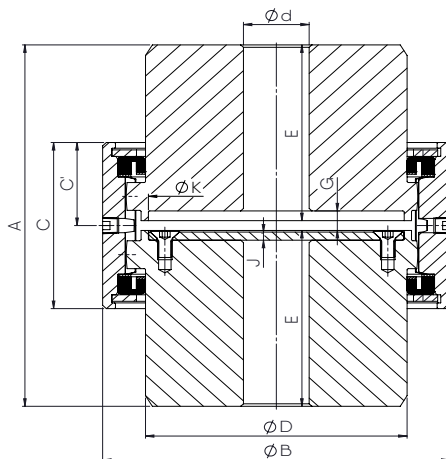

size	torque CSV		torque CSUV (1)		n max.	Ød min. (2)	Ød max. (3)	A	ØB	C	C'	ØD	E	G	J	ØK	weight (4)	inertia J (4)	max. misalignment		
	nominal T _n	peak T _p	nominal T _n	peak T _p															angular	radial	axial ±
CSV CSUV	kNm	kNm	kNm	kNm	rpm	dimensions in mm											kg	kgm ²	degree	mm	mm
30	0.55	1.10	1.10	2.20	5 500	0	35	80	84	50	25	50.9	38.5	3	3	49	2.0	0.002	2x0.5	0.1	1.5
40	1.10	2.20	2.20	4.40	5 100	0	42	95	95	65	32.5	60.4	46	3	5	57	3.4	0.004	2x0.5	0.1	2.5
55	1.97	3.94	3.94	7.9	4 400	22	63	110	120	68	34	82.6	53.5	3	5	76	6.0	0.010	2x0.5	0.1	2.5
65	3.24	6.48	6.48	13.0	4 000	25	75	120	140	80	40	100	57	6	6	95	9.8	0.021	2x0.5	0.3	3.0
80	5.6	11.2	11.2	22.4	3 600	38	90	140	168	95	47.5	121	67	6	6	121	15	0.052	2x0.5	0.1	3.0
100	8.5	17	17	34	3 400	38	110	222	190	102	51	143	108	6	6	140	32	0.171	2x0.5	0.3	3.0

- (1) Up-rated torque execution
- (2) Min. finish machine bore diameter (size ≥ 55)
- (3) Max. bore diameter with one keyway acc. DIN 6885/1
- (4) For pre-bored/unbored hubs

- Couplings can be supplied with several options (e.g. puller holes, set screws, ATEX, surface protection) → refer to page 43 et seqq. (B404a et seqq.)
- For the correct coupling selection please refer to page 16 et seqq. (A150a)
- For special executions or requirements, please contact us
- Technical modifications reserved and given values without engagement

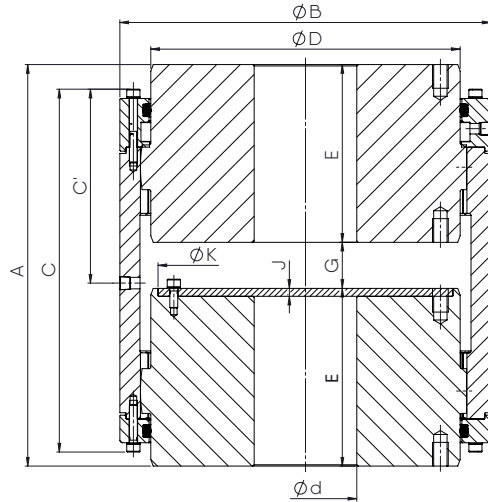
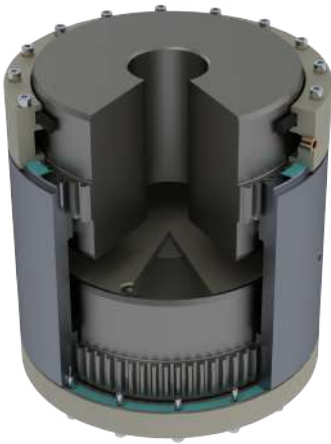

size	torque CSV...M		torque CSUV...M (1)		n1 max.	n2 max. (2)	Ød min. (3)	Ød max. (4)	A	ØB	C	C'	ØD	E	G	J	ØK	weight (5)	Inertia J (5)	max. misalignment		
	nominal Tn	peak Tp	nominal Tn	peak Tp																angular	radial	axial ±
CSV...M CSUV...M	kNm	kNm	kNm	kNm	rpm	rpm	dimensions in mm										kg	kgm ²	degree	mm	mm	
110M	16	32	32	64	3 350	4 700	0	112	199	186	196	109	151	90	19	5	140	34	0.45	2x0.75	1.6	2.5
130M	22	44	44	88	3 100	4 350	55	132	233	216	228	125	178	105	23	6	165	51	0.67	2x0.75	1.6	3.0
155M	32	64	64	128	2 800	4 000	65	158	264	254	250	136	213	120	24	6	200	80	1.01	2x0.75	2.1	3.0
175M	45	90	90	180	2 700	3 800	80	175	299	282	276	148	235	135	29	6	224	113	1.42	2x0.75	2.1	4.0
195M	62	124	124	248	2 550	3 600	90	198	332	317	301	161	263	150	32	6	250	156	2.10	2x0.75	2.3	4.0
215M	84	168	168	336	2 450	3 450	100	217	389	346	341	182	286	175	39	6	274	207	2.53	2x0.75	1.8	4.0
240M	115	230	230	460	2 300	3 300	120	244	426	376	368	195	316	190	46	6	302	262	3.06	2x0.75	2.0	4.0
275M	174	348	348	696	2 150	3 050	150	290	483	436	408	217	372	220	43	6	356	398	4.37	2x0.75	2.2	5.0

- (1) Up-rated torque execution
- (2) Special balancing recommended and use of high speed grease
- (3) Min. finish machine bore diameter (size ≥ 130)
- (4) Max. bore diameter with one keyway acc. DIN 6885/1
- (5) For pre-bored/unbored hubs

- Couplings can be supplied with several options (e.g. puller holes, set screws, ATEX, Viton O-Ring, surface protection) → refer to page 43 et seqq. (B404a et seqq.)
- For the correct coupling selection please refer to page 16 et seqq. (A150a)
- For special executions or requirements, please contact us
- Technical modifications reserved and given values without engagement

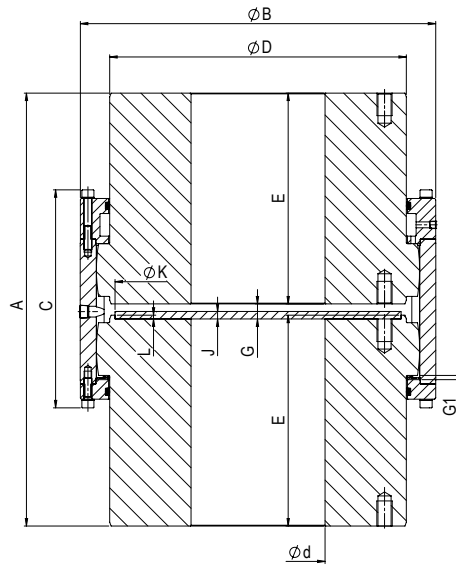
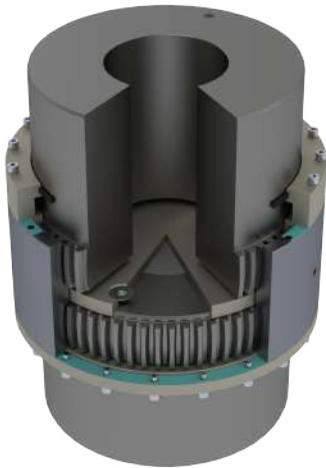

size	torque CSV		torque CSUV...N (1)		n max. rpm	Ød min. (2)	Ød max. (3)	A	ØB	C	ØD	E	G	G1	J	ØK	L	weight (4) kg	Inertia J (4) kgm ²	max. misalignment			
	nominal T _n	peak T _p	nominal T _n	peak T _p																angular degree	radial mm	axial ± mm	
CSV...N CSUV...N	kNm	kNm	kNm	kNm		dimensions mm													kg	kgm ²	degree	mm	mm
280N	244	488	488	976	1900	180	310	575	472	460	394	280	20	5.6	10	380	5	565	23	2x0.75	3.6	10	
320N	290	580	580	1160	1800	200	340	604	518	470	432	292	23	6.6	10	418	3	705	32	2x0.75	3.8	13	
360N	370	740	740	1480	1500	220	375	630	562	476	480	305	23	6.6	10	466	3	859	44	2x0.75	3.8	13	
400N	450	900	900	1800	1400	260	420	680	620	513	530	330	23	6.6	10	516	3	1098	67	2x0.75	4.0	13	
450N	560	1120	1120	2 240	1300	280	470	720	682	525	594	350	23	6.6	10	580	3	1432	101	2x0.75	4.2	13	

- (1) Up-rated torque execution
- (2) Min. finish machine bore diameter
- (3) Max. bore diameter with one keyway acc. DIN 6885/1
- (4) For pre-bored/unbored hubs

- Couplings can be supplied with several options (e.g. puller holes, set screws, ATEX, Viton O-Ring, surface protection) → refer to page 43 et seqq. (B404a et seqq.)
- For the correct coupling selection please refer to page 16 et seqq. (A150a)
- For special executions or requirements, please contact us
- Technical modifications reserved and given values without engagement

Further details and options

Puller holes and set screw

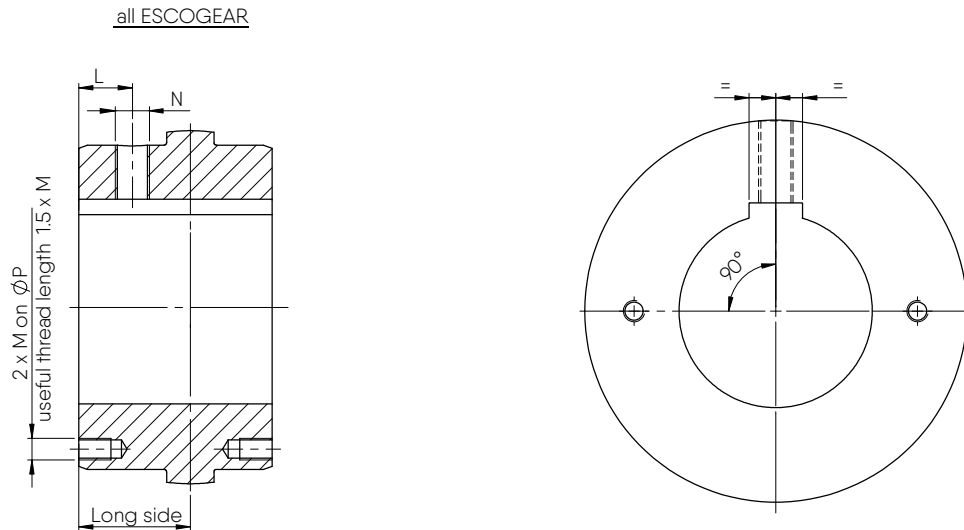

Size	Puller holes (mm) (1)		Set screw (mm)	
	M	P	L	N
30	M5	42	10	M6x6
40		50		
55	M6	70	15	M8x8
65		86		M10x10
80	M8	102	40	M12x12
100		125		
110M	M10	132	32	M16x16
130M		155	48	
155M	M12	186	42	M20x20
175M		205	50	
195M	M16	226	55	M24x24
215M		250	65	
240M	M20	276	70	M24x24
275M		330	82	
280N	M20	336	100	M24x24
320N		377	106	
360N	M24	420	114	M30x40
400N		480	129	
450N		544	142	

Size	Puller holes (mm) (1) (CCO)		Set screw (mm)	
	M	P	L	N
120M	M10	155	38	M16x16
150M		186	42	M20x20
165M	M12	205	50	
185M	M16	226	55	M24x24
210M		250	65	
230M	M20	276	70	M24x24
270M		330	82	

Balancing

Thanks to our high manufacturing quality, ESCOGEAR couplings have a high degree of natural inherent balance and generally don't require additional balancing for normal speed (N1) applications. Up to size 195, CST, CST...M & CST...N couplings have a minimum balance quality of Q6.3 at 800 rpm. For larger sizes, Q6.3 is reached without any additional balancing until 400 rpm.

Special balancing can be done on request. for higher speed bigger than N1 special balancing is mandatory.

1) Puller holes available as options from size 30 - 155. For sizes 175 and bigger puller holes are included by default.

Shaft connection

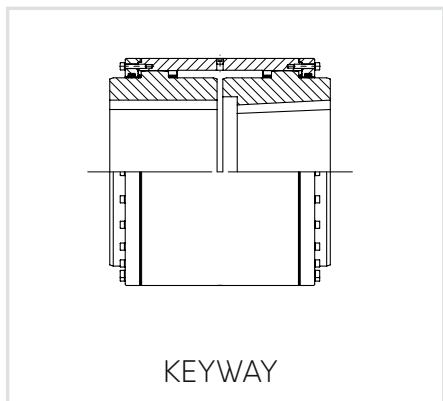

KEYWAY

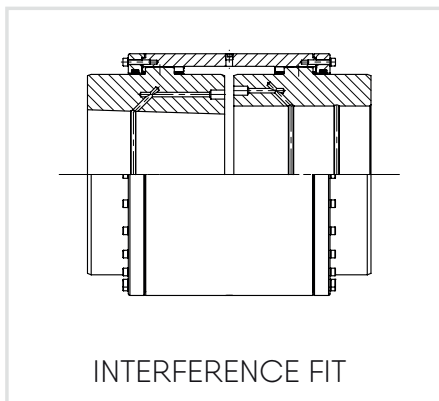

INTERFERENCE FIT

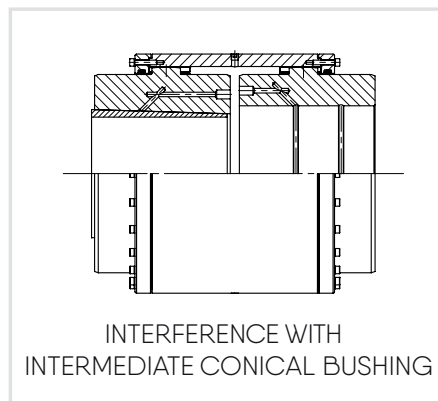

INTERFERENCE WITH
INTERMEDIATE CONICAL BUSHING

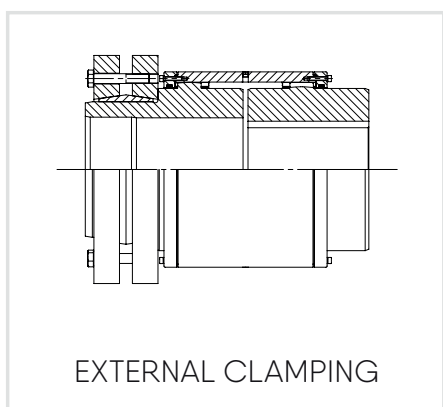

EXTERNAL CLAMPING

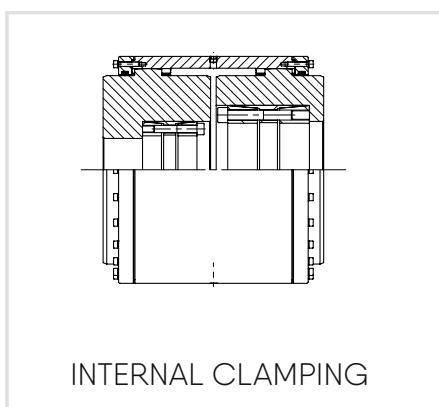

INTERNAL CLAMPING

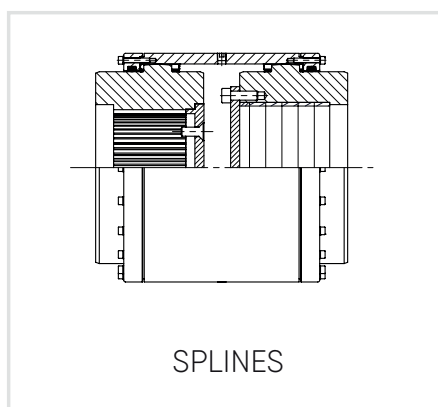

SPLINES

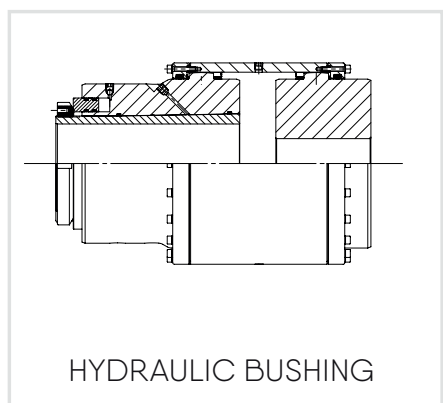

HYDRAULIC BUSHING

Protection

Coupling parts up to size 320 are black oxidized by default. Above that size coupling parts are oil waxed. Fitted bolts and screws are GEOMET 500 coated and nuts zinc plated. Additional black oxide or special paintings can be done on request.

Further designs and combinations

All ESCOGEAR couplings can be combined and extended almost without limit.
Please contact us for further details.

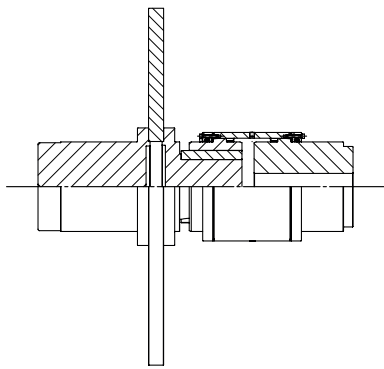

CDMMBD
DOUBLE MILL MOTOR WITH DYNAMIC BRAKE DISC

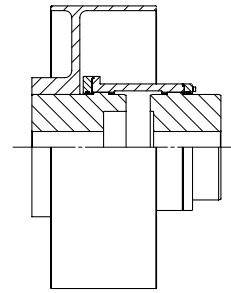

CMMBP
MILL MOTOR WITH BRAKE PULLEY

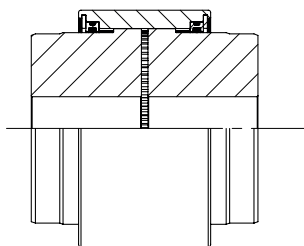

CDSH
DOUBLE SLIDING HUB

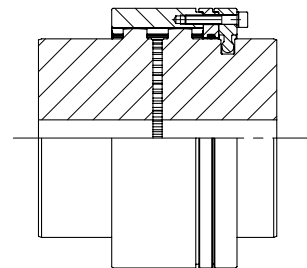

CLE
LIMITED END FLOAT

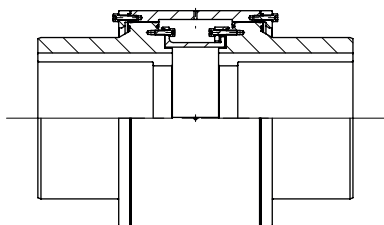

COFLE
OIL FLOW WITH LIMITED END

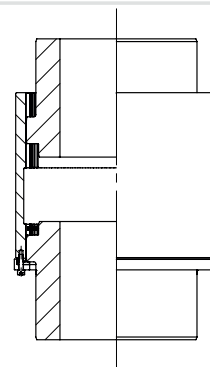

COFV
OIL FLOW WITH VERTICAL EXECUTION

Installation and maintenance

C..., C...M & C...N series

1) Introduction

Coupling must be properly selected according to selection chart on page A150a and corresponding charts. These documents are available in coupling catalogue ESCOGEAR C series or on our website www.escogroup.com.

Maximum misalignment figures during assembly and operations are given in above-cited document (values used in section 4 Assembly). Maximum misalignment, speed and torque may not be applied simultaneously as mentioned in the selection chart.

In case of any change or adaptation not performed by ESCO on the coupling, it is customers responsibility to size and manufacture it properly to guarantee safe torque transmission and absence of unbalance that could affect the life of the coupling and the connected machines.

If the interfaces are not calculated and machined by ESCO, it is customers responsibility to make sure that:

- In case of key
 - Shaft and key material, size and tolerance to suit the application
 - Hub length, bore diameter and machining tolerances will allow to transmit the torque; maximum bore capacity is given for information in the catalogue for DIN 6885/1 or NF E22-175.
- In case of interference fit
 - Interference and machining tolerances will transmit the torque and not exceed the permissible stress of hub material.

In case of spacer or floating shaft not supplied by ESCO, it is customer's responsibility to size and manufacture it properly to guarantee safe torque transmission and absence of unbalance that could affect the life of gearing on the connected machines.

The hubs must be axially secured on the shaft by means of either a setscrew or an end plate or a sufficient interference. It is customers responsibility to protect the coupling and to comply with the local safety rules regarding the protection of rotating parts.

e.g.: coupling guards

2) Preparation

Ensure the conformity of the supplied equipment:

- Verify coupling size and conformity (see catalogue or website)
- Check for any damaged and/or missing parts
- Verify conformity of the coupling/machine interfaces
- Coupling original protection allows for storage indoors dry 18 months, indoors humid 12 months, outdoors covered 9 months and outdoors open 3 months. For longer periods, it is customers responsibility to protect the parts properly.
- Instructions are a part of the supply of the coupling. Be sure that valid and complete Assembly, operation and maintenance instructions are available and well understood. In case of doubt, refer to ESCO.
- Please verify the BOM provided in the drawing for the conformity of the parts.

Before starting, verify the availability of the necessary tooling to:

- Manipulate the parts
- Assemble the interfaces
- Align the coupling
- Tighten the screws and nuts

Assembly, disassembly and maintenance must be performed by qualified, trained and competent fitters.

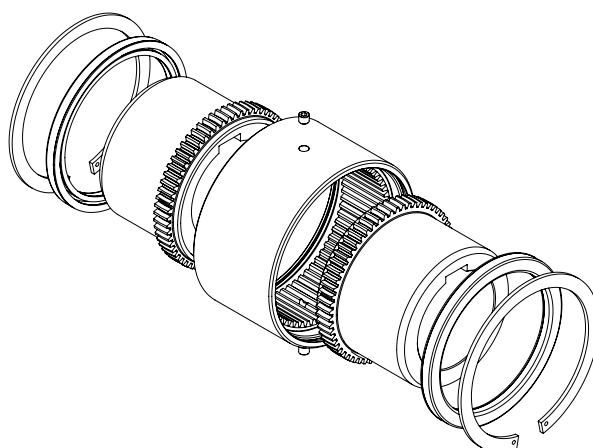

3) Warnings

In-charge installer and plan foreman are responsible of the installation safety. All adequate safety rules must be put in place for the assembly process.

Before removing the coupling guard and proceeding with any assembly, operation or maintenance operation of the coupling, make sure the complete system is completely shut down and definitively disengaged from any possible source of rotation, such as e.g.: electrical power supply or any loss of

braking effect.

Make sure everyone present in the equipment area will be properly informed (for example by means of warnings properly located) about the maintenance or assembly situation. In case of use in explosive atmospheres Ex specific protective measures must be considered.

They are described in an extra attachment (IM/A200d-EX) to the instructions with the couplings marked Ex .

4) Assembly C... couplings

4.1. C... couplings

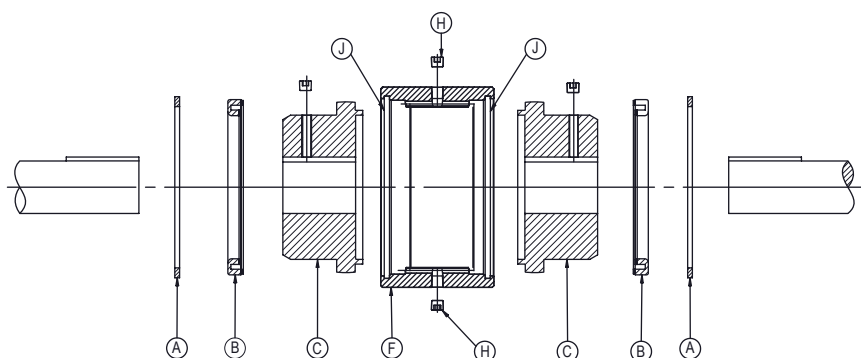

- 4.1.1. Ensure all parts are clean.
- 4.1.2. Place a snap ring (A) and a seal (B) on each shaft.
- 4.1.3. Install the hubs (C) on their respective shafts. For the assembly of the type CFS, see fig. 1 or 2. If needed, for keyway assembly, uniformly heat hubs (C) (max 120°C) to install them easily on the shaft, in this case, avoid any contact between the hub (C) and seal (B). Hub faces must be flush with shaft end. In case of doubt, please consult us. Introduce setscrew on key with Loctite and tighten properly. In case of interference fit, refer to ESCO for proper instructions.
- 4.1.4. Engage the sleeve (F) on the longest shaft.
- 4.1.5. Install units to be connected in place and check the spacing G between hubs. See tabulation 1 or approved drawing for correct hub spacing G, according to coupling size. In case of doubt, please consult us.
- 4.1.6. Align the two shafts, check alignment using an indicator. Alignment precision depends on running speed (see tabulation 4).
- 4.1.7. Coat hub and sleeve gearings with grease (see tabulation 3) and fill up with grease lubricant reservoir K. Lightly coat the aerofoil of both seals (B) with grease and slide sleeves (F) over hubs (C).
- 4.1.8. Slide the sleeve (F) over the hubs. Insert the seals (B) using a blunt tool. Insert the snap rings (A) in the grooves (J).

- 4.1.9. Remove both lube plugs (H) and force grease into bottom hole until clean grease flows out of top hole, holding the coupling to position lube holes at 45° to horizontal. For the type CFS, repeat this operation for the second sleeve. For quantity and quality of grease, see tabulation 3.
- 4.1.10. Re-install the 2 plugs (H). Tightening torque: 10 Nm, key size: s=5mm.

5) Inspection and maintenance C... couplings

- 5.1. Inspection

Regular inspection (audio-visual) must occur for leakage, noise, vibration, and loss of parts.
- 5.2. Maintenance
 - 5.2.1. Every 4 000 hours or every year:
 - Remove the 2 plugs (H).
 - Hold the coupling to position, lube holes at 45° to horizontal.
 - Force grease into bottom hole until clean grease flows out of top hole.
 - Re install the plugs (H). Tightening torque: 10 Nm.
 - 5.2.2. Every 8 000 hours or every 2 years:
 - Remove the snap rings (A) with tongs (F).
 - Clean and control gearing and sealing.
 - Control alignment; see point 4.1.6.
 - Reassemble coupling as per point 4.

4) Assembly C...M & C...N couplings

4.2. C...M & C...N couplings

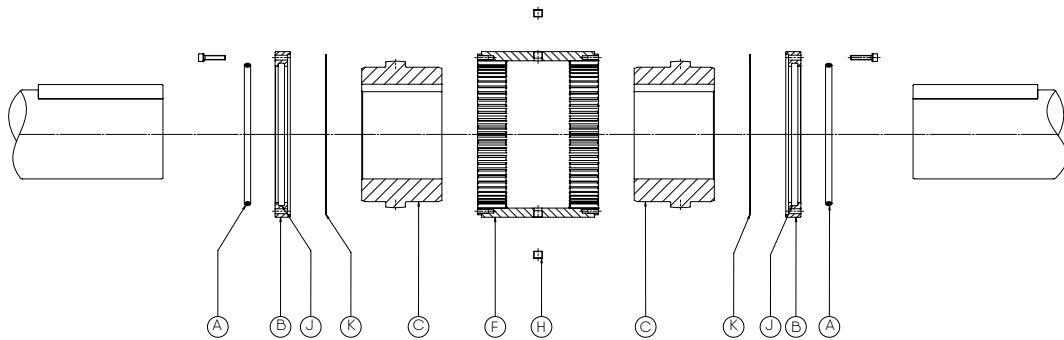

- 4.2.1. Ensure all parts are clean
- 4.2.2. Apply a light coat of grease to the O-Rings (A) and insert O-Rings into grooves (J) of end caps (B).
- 4.2.3. Place gaskets (K) and end caps (B) over both shafts. Care should be taken not to damage O-Rings (A).
- 4.2.4. Install hubs (C) on their respective shafts with the longest hub end towards shaft end or towards machine bearing depending on the type (see fig. 1 and 2). If needed, uniformly heat hubs (C) (max 120°C) to install them easily on the shaft, in this case, avoid any contact between the hub (C) and O-Ring (A). Hub faces must be flush with shaft ends. In case of doubt, please consult us. Introduce setscrew on key with Loctite and tighten properly. In case of interference fit, refer to ESCO for proper instructions.
- 4.2.5. Engage the sleeve (F) on the hub (C) on the longest shaft side.
- 4.2.6. Install units to be connected in place and check if the spacing G between hubs is the same as mentioned in tabulation 1 or in the approved drawing. In case of doubt, please consult us.
- 4.2.7. Align the two shafts, check alignment using an indicator. Alignment precision depends on running speed and torque (see tabulation 4).
- 4.2.8. Coat hub and sleeve gearings with grease (see tabulation 3) and slide the sleeve (F) over the hubs (C).

- 4.2.9. Coat with grease both ends of sleeve (F) and assemble end caps (B) with the gaskets (K) on sleeve (F). Tighten screws uniformly. See tabulation 2 for correct tightening torque (T1 Nm) and key size (s mm). Make sure that sleeve is freely sliding above hubs by axially displacing it to a value equal to G.
- 4.2.10. Remove both lube plugs (H) of sleeve (F) and add grease in sufficient amount to overflow with lubricant holes in horizontal position. For quantity and quality of grease, see tabulation 3. For the type of CSV...M, please consult us. Re-install the 2 plugs (H); see tabulation 2 for correct tightening torque (T2 Nm) and key size (s mm).

5) Inspection and maintenance C...M & C...N couplings

- 5.1. Inspection
 - Regular inspection (audio-visual) must occur for leakage, noise, vibration, and loss of parts.
- 5.2. Maintenance
 - 5.2.1. Every 4 000 hours or every year:
 - Check that sleeve is freely moving axially: follow instructions as indicated in Point 4.2.9.
 - Fill up grease level: Proceed as mentioned under 4.2.10.
 - 5.2.2. Every 8 000 hours or every 2 years:
 - Remove the screws and end caps (B).
 - Clean and control gearing and sealing.
 - Control alignment; see point 4.2.7.
 - Reassemble coupling as per point 4.

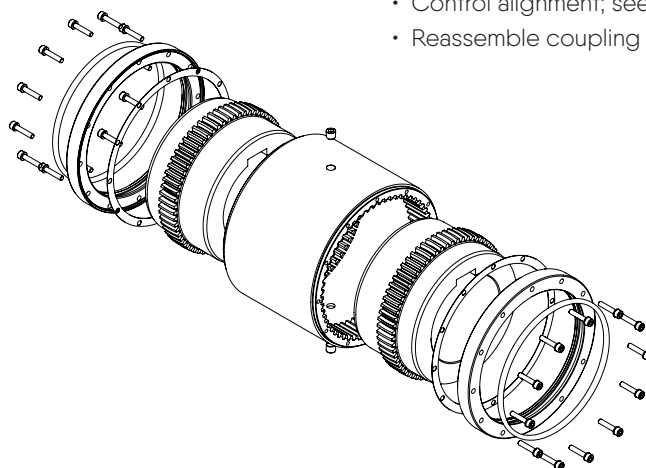

6) Tabulation and figures

TABLE 1 - DISTANCE BETWEEN SHAFT ENDS IN DIFFERENT COUPLING TYPES					
TYPE SIZE	CST, CMM, CDMM, CFS	CCO	CSS	CSV	CSH (min.)
30	3	6		3	4
40	3	6		5	4
55	3	6		5	4
65	6	7		6	4.2
80	6	11		6	4.2
100	6	12.5		6	5
110M	5	6	5	19	10
130M	6	6	6	23	11
155M	6	8	6	24	11
175M	8	8	8	29	14
195M	8	8	8	32	14
215M	8	8	8	39	16
240M	8	10	8	46	16
275M	10	10	10	43	18
280N	10			15	
320N	13			18	
360N	13			18	
400N	13			18	
450N	13			18	

TABLE 2 - TIGHTENING TORQUE					
TYPE SIZE	End Cap			Plug	
	T1	Hexagonal Socket head screw		T2	s
	Nm	M mm	s inch	Nm	mm
30	N/a	N/a	N/a	10	5
40	N/a	N/a	N/a	10	5
55	N/a	N/a	N/a	10	5
65	N/a	N/a	N/a	10	5
80	N/a	N/a	N/a	10	5
100	N/a	N/a	N/a	10	5
110M	8	5	4	10	5
130M	8	5	4	10	5
155M	8	5	4	10	5
175M	13	6	5	10	5
195M	13	6	5	10	5
215M	33	8	6	29	8
240M	33	8	6	29	8
275M	33	10	6	29	8
280N	65	10	8	29	8
320N	65	10	8	29	8
360N	65	10	8	29	8
400N	112	12	10	29	8
450N	112	12	10	29	8

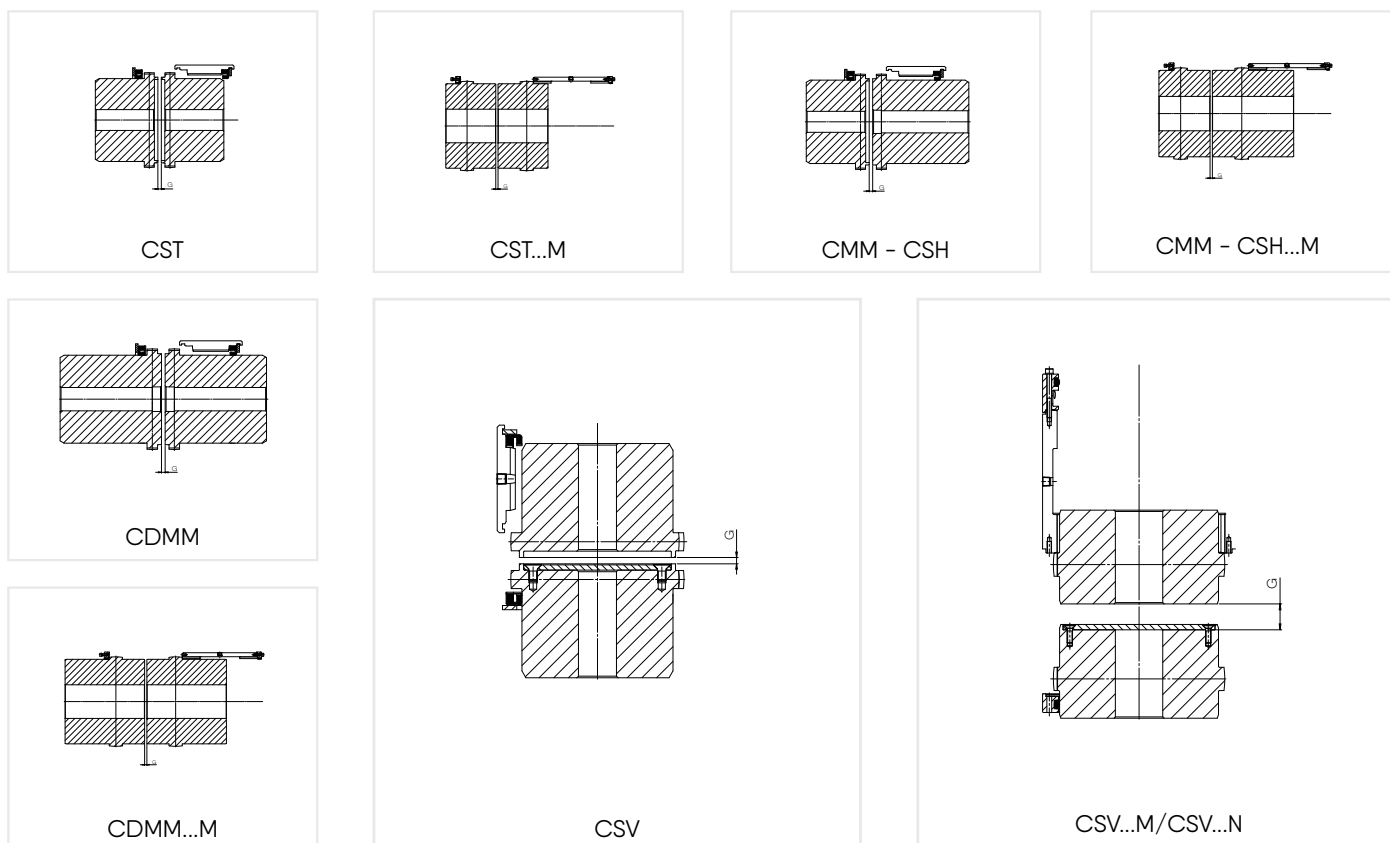
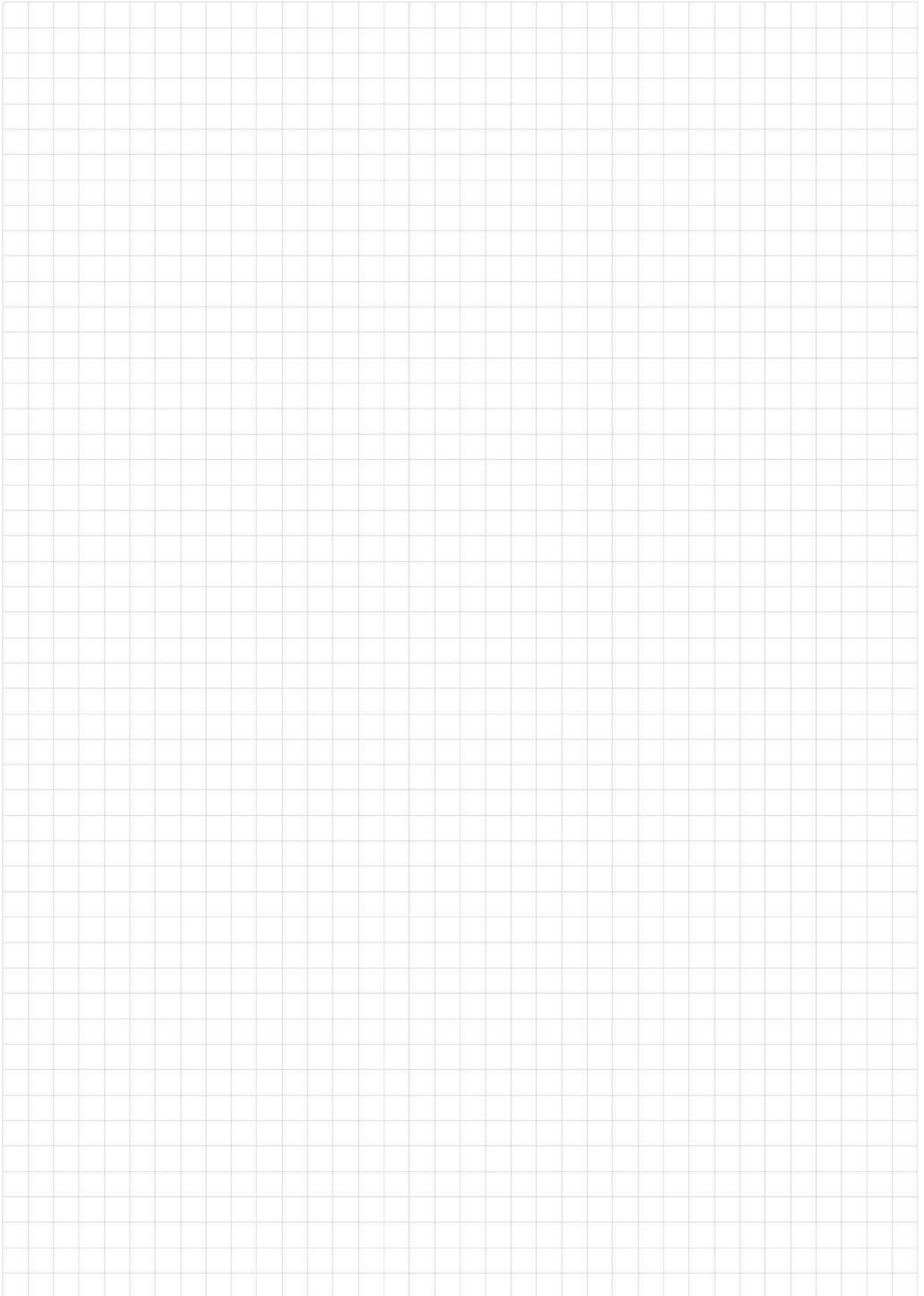

TABLE 3 - RECOMMENDED LUBRICANTS AND QUANTITY				TYPE SIZE	CST CMM CDMM dm ³	CFS dm ³	CSV dm ³	CCO dm ³
NORMAL SPEED AND DUTY		HIGH SPEED, HEAVY DUTY AND ATEX						
Eni	GR MU/EP1			30	0.022	2x0.022	0.022	0.035
Caltex	Coupling Grease	Caltex	Coupling Grease	40	0.036	2x0.036	0.036	0.058
Chevon	Coupling Grease	Chevon	Coupling Grease	55	0.063	2x0.063	0.063	0.094
Klüber	Klüberplex GE 11-680	Klüber	Klüberplex GE 11-680	65	0.114	2x0.114	0.114	0.172
Mobil	Mobilus EPO or EP004	Mobil	Mobilgrease XTC	80	0.201	2x0.201	0.201	0.295
Mobil	Mobilgrease XTC	Texaco	Coupling Grease	100	0.27	2x0.27	0.27	0.435
Q8	Rembrandt EPO			110M	0.33	2x0.17	0.316	0.62
Shell	Gadus S2 V220			130M	0.48	2x0.24	0.465	0.96
Shell	Gadus S3 V220C			155M	0.74	2x0.38	0.739	1.18
Texaco	Coupling Grease			175M	0.89	2x0.45	0.872	1.82
Total	MULTIS EP 1			195M	1.39	2x0.7	1.403	2.44
				215M	1.87	2x0.92	1.909	2.94
				240M	2.26	2x1.17	2.437	4.02
				275M	3.4	2x1.701	4.37	
				280N	6.07			
				320N	7.81			
				360N	9.16			
				400N	11.66			
				450N	13.62			

Notes:



ATEX

Specific protective measures taken for ESCOGEAR couplings in case of use in explosive atmospheres.

1) Introduction

General assembly and maintenance instructions (called IM in this attachment) are established for standard ESCOGEAR couplings according to the following list:

- IM/B200a for ESCOGEAR NST couplings
- IM/B300a for ESCOGEAR CST couplings
- IM/B400a for ESCOGEAR FST couplings

In case of use in potentially explosive atmospheres, further to the general assembly and maintenance instructions (IM/...), the specific measures described in this attachment must be taken.

2) Coupling Selection

The coupling must be selected according to the general assembly and maintenance instruction IM/...

In explosive atmosphere Ex , the following specific rules must apply:

- A Service Factor of 2 must be applied on the max. torque values given in the charts in catalogue (see Selection chart A140ff.).
- A Service Factor of 2 must be applied on the reference torque values given on the selection chart A140a for the calculation of max. misalignment in operation.
- Max. misalignment (combination of angular and offset) may not exceed 0.5° per gear mesh.

3) Use of the coupling

The coupling is dedicated to be used in potentially explosive atmospheres according to European Directive 2014/34/EU (ATEX 100A).

Coupling is classified in equipment group II, equipment category 2 and 3, intended to be used in areas in which explosive atmospheres caused by gases, vapours, mists of air/dust mixtures are likely to occur.

In function of the ambient temperature in the coupling proximity (65, 55, 40°C), the temperature classes have been defined (T4, T5, T6).

This is based on a temperature increase of the machine shafts (in regard of the ambient temperature) that will not exceed 40°C in operation.

The coupling is marked as follows:

**CE Ex II 2 G T4/T5/T6 D 105°C
 $-20^\circ\text{C} \leq T_a \leq 65^\circ\text{C}/55^\circ\text{C}/40^\circ\text{C}$**

This marking covers the T3 temperature category.

This marking covers all gas categories: G IIA, G IIB and G IIC.

4) Warnings

The warnings mentioned in the general assembly and maintenance instructions IM/... must apply in any case.

In explosive atmospheres Ex , the following specific warnings must apply:

- Complete machining of the coupling parts (bores, keyways, spacers, floating shafts etc...) must be performed by ESCO Couplings SRL. No modification shall be made on the supplied and marked product without the agreement of ESCO Couplings SRL.
- In case of supply by ESCO Couplings SRL of couplings with a rough bore or a solid bore, the sole allowed operation that may be performed by customer is the boring and keywaying of the coupling hubs.

When machining the bore and the keyway, the following instructions must be followed:

- This job must be performed by an authorised and adequately trained and informed operator.
- The bore and keyway tolerances must be selected to ensure the proper fit between shaft and bore. In case of loose fit, a set screw must be foreseen to locate the hub axially.
- The max. bore may not exceed the value stated in the catalogue. The tabulated values in the catalogue are based on key dimensions according to ISO R773.
- The reference used to center the piece when boring, is the one referenced D in the figures of the catalogue.
- Before proceeding with any assembly, operation or maintenance operation on the coupling, make sure that the necessary measures have been taken to ensure safety, such as but not limited to:
 - Proper ventilation of the area
 - Proper lightning and electrical tools.
- If hub must be heated for assembly on the shaft, make sure heating source and surface temperature will not affect the safety of the working area.

- It is recommended to have a strong coupling guard, preferably in stainless steel with openings (if any) smaller than the smallest centrifugable part (plug is 6 mm dia). The coupling guard is intended to protect the environment from the centrifugation of any rotating part and the rotating coupling from any falling part. To limit ventilation effects, distance between cover and coupling outside surface should be at least 10 mm.

5) Assembly

The general assembly and maintenance instructions IM/... must apply in any case.

In explosive atmospheres Ex , the following specific instructions must apply:

- Alignment of the machine in cold condition must take into account the possible heat expansion to make sure that in continuous running conditions, max. misalignment calculated in A152a will not be exceeded.
- Max. misalignment may never exceed 0.5° per gear mesh.
- To improve the coefficient of friction and the leakage resistance, use following lubricants dedicated for gear couplings:
 - CHEVRON Coupling Grease
 - CALTEX Coupling Grease
 - KLÜBER Klüberplex GE11-680
 - MOBIL Mobilgrease XTC
 - TEXACO/MULTIFAK Coupling Grease

6) Operation

The general assembly and maintenance instructions IM/... must apply in any case.

In explosive atmospheres Ex , the following specific instructions must apply:

- Before Start-up
 - Make sure, screws, nuts and plugs are properly tightened.
 - Coupling guard must be properly installed and fixed.
 - Monitoring system, if any, must be tested to verify its effectiveness.

- During start up
 - Check for any leakage. In case of abnormal leakage, immediate stop is mandatory and appropriate actions must be taken.
 - Check for any abnormal noise and/or vibration. If any, immediate stop is mandatory and appropriate actions must be taken.
- Checking intervals during operation
 - After the first 2 000 hours or 6 months; check:
 - For leakage, noise, vibration and loss of parts.
 - For free axial movement of the sleeves in regard of the hubs.
 - After 4 000 hours or one year
 - For leakage, noise, vibration and loss of parts.
 - For free axial movement of the sleeves in regard of the hubs.
- Continuous checking
 - Immediately stop the machine if noise, vibrations or other abnormal phenomena are detected during operation.
 - Further more, if direct check is not possible for access or safety reasons, proper monitoring system has to be installed to follow up couplings behaviour.

7) Maintenance

The general assembly and maintenance instructions IM/... must apply in any case.

In explosive atmospheres Ex , the following specific instructions must apply:

- Every 6 000 hours or 1.5 years:
 - Dismount the coupling and inspect
 - Proceed as indicated in point 4.



ESCO worldwide

ESCO Couplings SRL

Avenue Ernest Solvay, 48

B - 1480 Saintes

Belgium

Tel + 32 (0) 2 715 65 60

Fax + 32 (0) 2 720 83 62

e-mail: info@esco-couplings.be

website: www.escogroup.com



ESCO Couplings & Transmissions Pvt. Ltd.

Plot No. 69-D

Bengaluru Aerospace Park

Unachuru Village Jala Hobli

Bengaluru

India

Tel +91 80 7100 1800

e-mail: info@esco-couplings.co.in

website: www.escogroup.com

Local Contact

Authorised distributor



TYMA CZ, s.r.o.

Na Pískách 731/12

CZ - 40004 Trmice, Czech Republic

Phone: +420 475 655 010

Email: info@tyma.cz

www.tyma.cz

Version 01-2025