

# ESCODISC D series

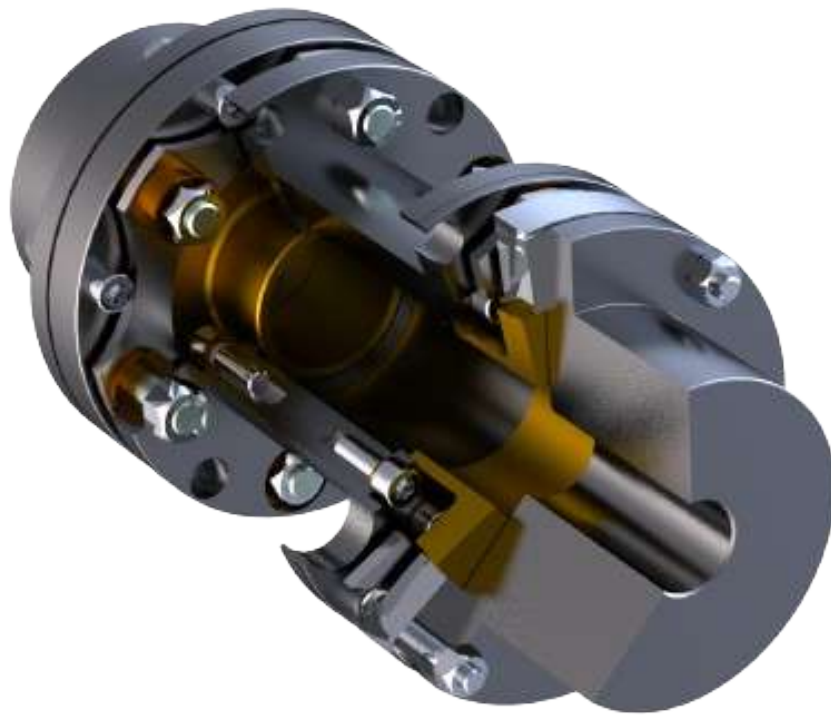

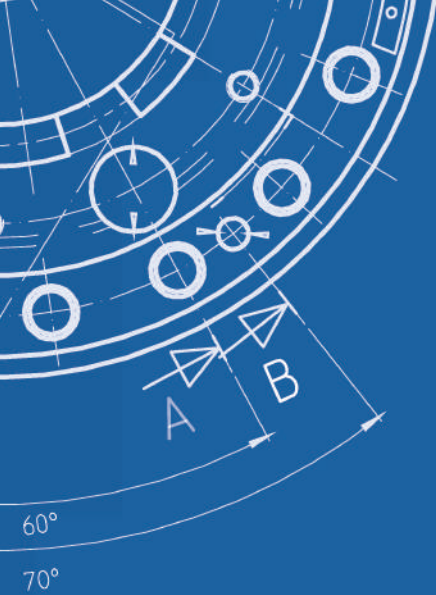

## INDEX

We connect the world .....	5	DMUFR 190-220 to 360-370 .....	27
Global footprint .....	6	DPU 28-45 to 160-220 .....	28
The right solution for your application .....	8	DPU Corrosive environment 28-45 to 160-220 ..	29
Why ESCODISC D? .....	10	DPU 190-290 to 360-575 .....	30
Availabilities .....	14	Notes .....	31
How to select the right coupling size .....	15	Further details and options .....	32
DLC 28-28 to 85-105 .....	18	Further designs and combinations .....	35
DLCC 28-20 to 85-85 .....	19	Installation and maintenance DLC series .....	38
DLFR 28-28 to 85-105 .....	20	Installation and maintenance DMU series .....	41
Notes .....	21	Installation and maintenance DMUCC series ....	45
DMU 28-28 to 160-185 .....	22	Notes .....	49
DMU 190-220 to 360-370 .....	23	Installation and maintenance DPU series .....	50
DMUCC 28-20 to 160-170 .....	24	ATEX .....	54
DMUCC 190-210 to 360-360 .....	25	Contact us! .....	56
DMUFR 28-28 to 160-185 .....	26		





## We connect the world

We are more than a 75 years old family-owned company specialized in designing and manufacturing high-quality custom-made power transmission products.

Because we believe each transmission challenge is different, we create much more than off-the shelf products: we work hand in hand with our customers to develop the coupling solutions that best fit their specific needs.

Superior product quality is what guarantees our customer's success, it is what enables us to cherish long term partnerships with them. The ESCO quality has been worldly renown for decades and we work tirelessly to raise these standards even further.

We strive to be a significant contributor to the development of effective and clean industrial, transportation and energy supply applications. We want our couplings to power a more sustainable world.

We strongly believe that both the future of our economy and the best guarantee for long term return lie in sustainable development. And we want to do our part.

Once we get involved into a specific sector, we make sure to embrace the quality standards that the market requires. This is why, we are ISO 9001 certified.



A global footprint, with a family of  
9 companies located all across the world



9

offices across  
the world

3

manufacturing  
sites

● ESCO Couplings SRL  
*Saintes, Belgium*  
Tel. +32 (0) 2 715 65 60  
info@esco-couplings.be

● ESCO Couplings & Transmissions Pvt. Ltd.  
*Bengaluru, India*  
Tel. +91 80 7100 1800  
info@esco-couplings.co.in

● ESCO Power SRL  
*Saintes, Belgium*  
Tel. +32 (0) 2 717 64 90  
info@escopower.be

● EFECO Services Pvt. LTd  
*Bengaluru, India*  
Tel. +91 80 4977 7088

● ESCO Couplings Ltd.  
*Jinan, China*  
Tel. 86 (531) 827 625 65  
info@esco-couplings.com



- Head-office & Manufacturing site
- Manufacturing sites
- Sales offices & Service centres

● ESCO Aandrijvingen B.V.  
*Alphen A/D Rijn, The Netherlands*  
Tel. +31 (0) 172 42 33 33  
[info@esco-aandrijvingen.nl](mailto:info@esco-aandrijvingen.nl)

● esco antriebstechnik gmbh  
*Troisdorf, Germany*  
Tel. +49 (0) 2241 48 07 0  
[info@esco-antriebstechnik.com](mailto:info@esco-antriebstechnik.com)

● ESCO Drives SRL  
*Saintes, Belgium*  
Tel. +32 (0) 2 717 64 60  
[sales@esco.be](mailto:sales@esco.be)

● ESCO Transmissions SAS.  
*Saint Witz, France*  
Tel. +33 (1) 34 31 95 95  
[info@esco-transmissions.fr](mailto:info@esco-transmissions.fr)

We work with you to design the right  
solution for your application





---

Versatility, robustness, efficiency and long life, these are only a few of the many high demands on the gear couplings. These properties are the reason why gear couplings are that popular in multiple industries as they can get along with all different harsh conditions.

---

Since the competitiveness of the technical and economic aspects of the production needs to be more and more effective in the long-term, the machines used in the applications need to be able to run continuously, without failure. Furthermore, maintenance operations should be as short and seamless as possible to minimize costly production down time.

Minimizing the life cycle cost of the installation requires careful attention when selecting the elements of the driveline. A high-quality coupling will make a difference between an efficient, cost effective transmission, and a poorly optimized one.

This is where ESCO can help you. We have been helping our customers by designing high-quality tailor-made couplings for more than 40 years:

**Quality is our motto, our core competency:** ESCO products are amongst the most reliable in the market; so much so that the main hurdle in our capacity to innovate is the lack of market feedback: our couplings just keep running without issues.

**Low lifecycle cost might well be the biggest challenge for ESCO to tackle, but we do work tirelessly to optimize the life time value of our couplings:** fair initial price, smaller footprint (space and weight), longer design life, lubrication-free alternatives, extended maintenance steps...

**Service is an important part of our business:** to best serve your needs, you can count on our experienced team and advanced testing capability. We are more than happy to assist in performing field interventions, maintenance and repair.

Our relationship with customers does not stop once couplings are delivered. We have a team of experienced people ready to perform service on the field, repair, inspections, testing... We can also do the maintenance on our couplings for you. This guarantees proper execution of the maintenance instructions and contributes to improving the lifetime of your application.

**ESCO specializes in the design of custom made couplings. If you cannot find a solution that fits your needs, please contact us: we will work hard to engineer the coupling that fits your application specifications.**

# Why ESCODISC D?

---

## Improves efficiency of machine design and coupling selection

---

### High torque and misalignment capacity

Thanks to the optimised disc shape and thickness (which could be obtained by finite element analysis and laser cutting), the optimised number of bolts and the standard use of 12.9 quality bolts, ESCODISC couplings have a high torque and misalignment capacity combined with reduced reaction forces on connected equipment (bearings, mechanical seals...).

### Infinite life

All ESCODISC couplings have been calculated, designed and tested for infinite life. This is possible thanks to the use of discs in AISI 301 stainless steel with special surface treatment, the standard use of fillers between the discs to eliminate fretting corrosion and the use of high safety margin on catalogue values.

### No buckling

In order to guarantee perfect centring of the spacer under all working condition (very important for long DBSE applications) and well controlled stresses in the disc pack, ESCODISC couplings have been calculated and tested to have no buckling up to the peak torque. This results in trouble free operation, maximum efficiency and reduced risk for disc failure.

### Flexible spacer design

Thanks to the unique design of the ESCODISC spacer (flanges bolted to the intermediate tube section - see catalogue drawings DMU/DPU), its length is easily adaptable to customer requirements. Therefore quick delivery (even for non-standard DBSE) is possible and customer stock can be reduced to a minimum level.

### Suitable for extreme temperatures and corrosive environment

ESCODISC couplings can operate at temperatures as high as 270°C and as low as -20°C, (lower or higher temperature level on request). Furthermore, thanks to the use of stainless steel discs, the standard use of Dacromet protection for the hardware and a special surface treatment, ESCODISC couplings are ideal for use in a corrosive environment.

### Easy assembly and disassembly

To save cost at the assembly and the disassembly stages, the design of all ESCODISC couplings has been optimised (factory assembled disc pack or transmission unit, ship- ping screws...).

### Torque transmission in case of disc pack failure

In the unlikely event of a disc pack failure, the ESCODISC couplings have been designed in such a way that torque transmission remains guaranteed for a limited time (through the bolts). This system furthermore keeps the spacer well centred and works as an anti-fly system through which optimum user safety can be assured.

# DLC

The Economic Single Disc Concept for low to medium duty applications  
 Maximum torque capacity: up to 1 600 Nm – Bore Capacity: up to 105 mm

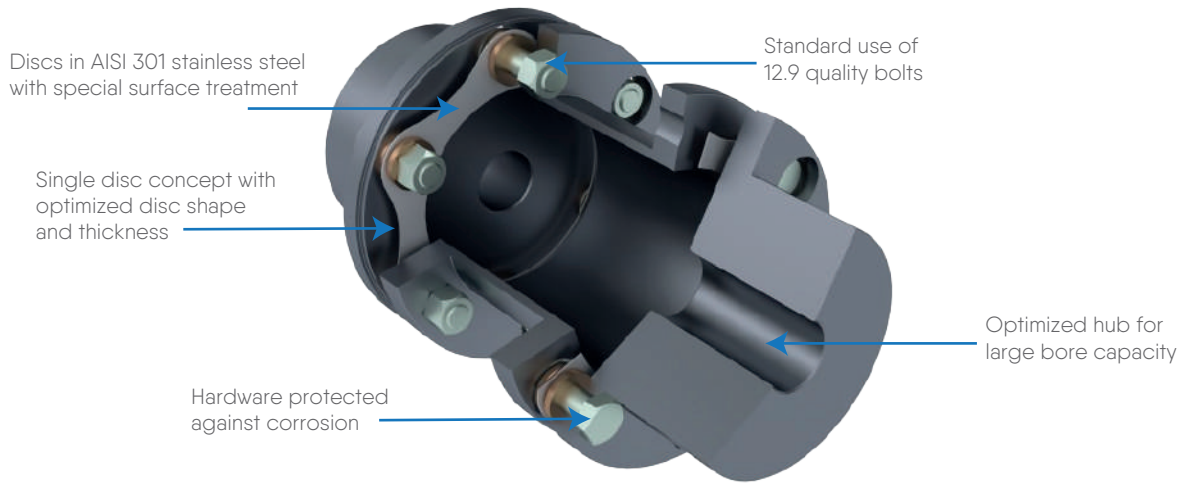

## Economic solution

The simplified design and single disc concept of the ESCODISC DLC makes it the most cost effective solution for simple low to medium torque/speed applications where a maintenance free coupling is required.

## Close coupled design

The ESCODISC DLC coupling is also available in close coupled design (DLCC) to provide the user with a very compact solution for his application. A distance between shaft ends as small as 3 mm can be obtained with maximum misalignment capacity.

## Single disc concept

Thanks to finite element analysis and the standard use of laser cutting, the single disc concept can be used without problems (no fretting corrosion, no buckling) for low to medium duty applications.

## ESCODISC Series DLC - Quick selection table

Coupling size	maximum power (kW)															max. speed (rpm)	max. bore (mm)
	1 000 rpm			1 500 rpm			1 800 rpm			3 000 rpm			3 600 rpm				
	SF 1	SF 1.5	SF 2	SF 1	SF 1.5	SF 2	SF 1	SF 1.5	SF 2	SF 1	SF 1.5	SF 2	SF 1	SF 1.5	SF 2		
28-28	7	5	4	11	7	5	13	9	7	22	15	11	26	18	13	5 800	28
38-45	12	8	6	17	12	9	21	14	10	35	23	17	41	28	21	5 000	45
45-55	21	14	10	31	21	16	38	25	19	63	42	31	75	50	38	5 600	55
55-65	37	24	18	55	37	27	66	44	33	110	73	55	132	88	66	4 600	65
65-75	68	45	34	102	68	51	123	82	61	204	136	102	245	163	123	3 900	75
75-90	105	70	52	157	105	79	188	126	94	314	209	157	377	251	188	3 500	90
85-105	168	112	84	251	168	126	302	201	151	503	335	251	603	402	302	3 000	105

The General Purpose High Torque/High Misalignment Solution

Maximum torque capacity: up to 260 000 Nm – Bore Capacity: up to 370 mm

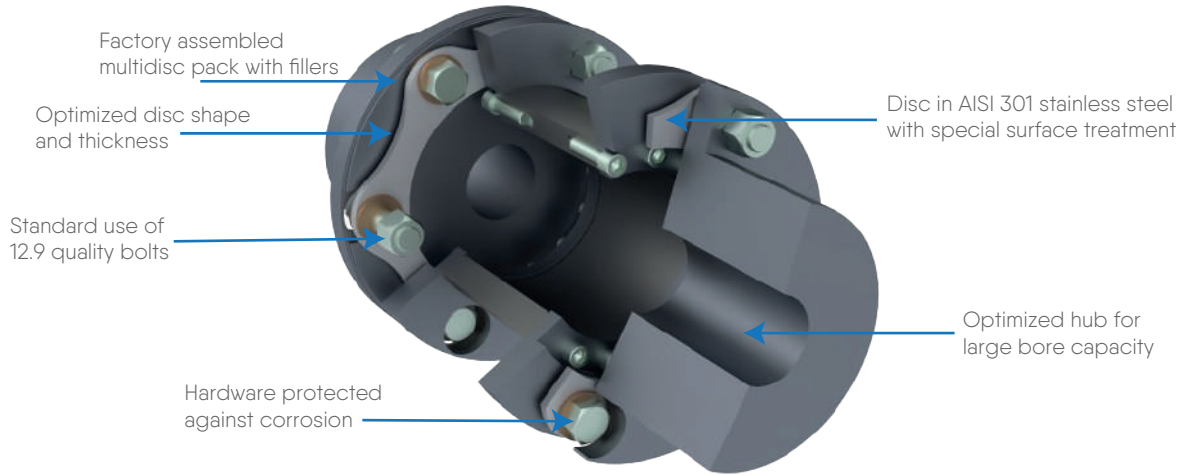

General purpose design

Because of the high torque, bore and misalignment capacity of the ESCODISC DMU coupling range, its high degree of natural inherent balance (AGMA class 9) up to size 85, this coupling is the ideal solution in a multitude of applications up to 260 000 Nm (and larger upon request).

Close coupled design

The ESCODISC DMU coupling is also available in close coupled design (DMUCC). The high torque/bore capacity makes it an ideal maintenance free alternative for close coupled gear and elastic type couplings and can be modified in such a way that replacement of gear and elastic couplings is possible without modifications to an existing installation. Furthermore, thanks to the split spacer design, disconnection of the two machines and replacement of the disc pack is possible without axial displacement of the connected machines.

Unitised disc pack

The DMU disc pack consists of an optimised number of discs or separated links (for sizes greater or equal to size 190) and has been factory assembled for easy field assembly. To eliminate fretting corrosion (which limits disc type coupling life), stainless steel fillers between the discs are used.

ESCODISC Series DMU - Quick selection table

Coupling size	maximum power (kW)															max. speed (rpm)	max. bore (mm)
	1 000 rpm			1 500 rpm			1 800 rpm			3 000 rpm			3 600 rpm				
	SF 1	SF 1.5	SF 2	SF 1	SF 1.5	SF2	SF 1	SF 1.5	SF2	SF 1	SF 1.5	SF2	SF 1	SF 1.5	SF2		
38-45	20	13	10	30	20	15	36	24	18	60	40	30	72	48	36	16 000	45
45-55	35	23	17	52	35	26	62	41	31	104	69	52	124	83	62	13 600	55
55-65	79	52	39	118	79	59	141	94	71	236	157	118	283	188	141	12 000	65
65-75	139	93	70	209	139	104	251	167	125	418	279	209	501	334	251	10 000	75
75-90	230	154	115	346	230	173	415	276	207	691	461	346	829	553	415	8 600	90
85-105	366	244	183	550	366	275	660	440	330	1 099	733	550	1 319	880	660	7 200	105
95-105	586	391	293	880	586	440	1 056	704	528	1 759	1 173	880	2 111	1 407	1 056	6 400	105
110-120	838	558	419	1 257	838	628	1 508	1 005	754	2 513	1 675	1 257	3 016	2 010	1 508	5 600	120
125-135	1 141	761	571	1 712	1 141	856	2 054	1 370	1 027	3 424	2 283	1 712	4 109	2 739	2 054	5 000	135
140-160	1 487	991	744	2 231	1 487	1 115	2 677	1 784	1 338	4 461	2 974	2 231	5 353	3 569	2 677	4 600	160
160-185	2 074	1 383	1 037	3 109	2 073	1 554	3 735	2 490	1 868	6 226	4 151	3 113	11 245	7 497	5 623	4 000	185

Coupling size	maximum power (kW)															max. speed (rpm)	max. bore (mm)
	200 rpm			400 rpm			600 rpm			750 rpm			850 rpm				
	SF 1	SF 1.5	SF 2	SF 1	SF 1.5	SF2	SF 1	SF 1.5	SF2	SF 1	SF 1.5	SF2	SF 1	SF 1.5	SF2		
190-220	643	429	321	1 286	857	429	1 929	1 286	964	2 411	1 607	1 205	2 732	1 822	1 366	1 800	220
220-255	1 110	740	555	2 220	1 480	740	3 330	2 220	1 665	4 162	2 775	2 081	4 717	3 145	2 359	1 500	255
250-290	1 948	1 298	974	3 895	2 597	1 298	5 843	3 895	2 921	7 304	4 869	3 652	8 277	5 518	4 139	1 300	290
280-320	2 513	1 675	1 257	5 026	3 351	1 675	7 539	5 026	3 770	9 424	6 283	4 712	10 681	7 120	5 340	1 200	320
320-360	3 497	2 332	1 749	6 995	4 663	2 332	10 492	6 995	5 246	13 115	8 743	6 558	14 864	9 909	7 432	1 050	360
360-370	5 445	3 630	2 723	10 890	7 260	3 630	16 335	10 890	8 168	20 419	13 613	10 209	23 141	15 428	11 571	900	370

The easy to assemble High Torque/High Misalignment Solution

Maximum torque capacity: up to 260 000 Nm – Bore Capacity: up to 575 mm

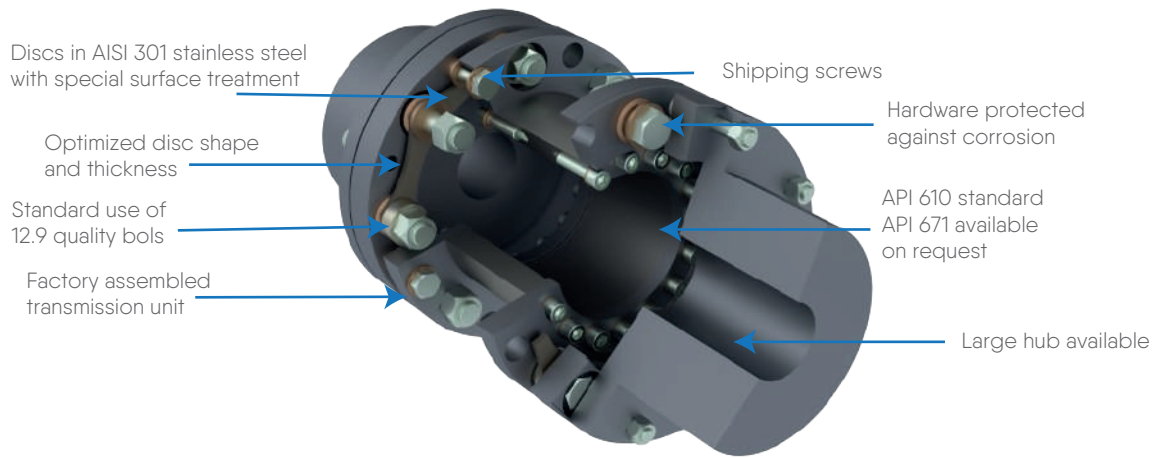

**Easy assembly and disassembly**

Thanks to the standard use of shipping screws and the factory assembled transmission unit, ESCODISC DPU couplings combine the high torque and misalignment capacity of the DMU couplings with easiness of assembly. On average users can cut down assembly and disassembly costs by 50% when using ESCODISC DPU couplings. Furthermore, because the transmission unit is factory assembled, the risk for assembly errors is reduced to an absolute minimum level which results in reliable operation and extended life of the coupling.

**High speed/long DBSE applications**

Thanks to the concept of the DPU coupling range (centring spigots) and the high manufacturing standards, it is ideal for use in medium to high speed applications with no or minor modifications. Furthermore, thanks to the perfect centring of the transmission unit, it can be used in applications where a long DBSE is required (e.g. cooling towers) and it can be adapted to meet the API 671 requirements.

**Large bore capacity**

The Large hub execution (L-hub) of the ESCODISC DPU series makes selection virtually independent of the shaft size which makes it possible in several applications to downsize compared with DLC or DMU type couplings.

**ESCODISC Series DPU – Quick selection table**

Coupling size	maximum power (kW)															max. speed (rpm)	max. bore	
	1 000 rpm			1 500 rpm			1 800 rpm			3 000 rpm			3 600 rpm				S-hub (mm)	L-hub (mm)
	SF 1	SF 1.5	SF 2	SF 1	SF 1.5	SF 2	SF 1	SF 1.5	SF 2	SF 1	SF 1.5	SF 2	SF 1	SF 1.5	SF 2			
38-60	20	13	10	30	20	15	36	24	18	60	40	30	72	48	36	24 000	45	60
45-70	35	23	17	52	35	26	62	41	31	104	69	52	124	83	62	20 400	55	70
55-80	79	52	39	118	79	59	141	94	71	236	157	118	283	188	141	18 000	65	80
65-100	139	93	70	209	139	104	251	167	125	418	279	209	501	334	251	15 000	75	100
75-110	230	154	115	346	230	173	415	276	207	691	461	346	829	553	415	12 900	90	110
85-130	366	244	183	550	366	275	660	440	330	1 099	733	550	1 319	880	660	10 800	105	130
95-145	696	464	348	1 044	696	522	1 253	836	627	2 089	1 393	1 044	2 507	1 671	1 253	9 600	105	145
110-160	979	653	490	1 469	979	734	1 762	1 175	881	2 937	1 958	1 469	3 525	2 350	1 762	8 400	120	160
125-180	1 330	887	665	1 995	1 330	997	2 394	1 596	1 197	3 990	2 660	1 995	4 887	3 192	2 394	7 500	135	180
140-200	1 738	1 159	869	2 607	1 738	1 304	3 129	2 086	1 564	5 215	3 476	2 607	6 258	4 172	3 129	6 900	160	200
160-220	2 149	1 613	1 075	3 626	2 418	1 813	4 358	2 906	2 179	7 624	4 843	3 626	8 719	5 811	4 359	6 000	185	220

Coupling size	maximum power (kW)															max. speed (rpm)	max. bore	
	200 rpm			400 rpm			600 rpm			750 rpm			850 rpm				S-hub (mm)	L-hub (mm)
	SF 1	SF 1.5	SF 2	SF 1	SF 1.5	SF 2	SF 1	SF 1.5	SF 2	SF 1	SF 1.5	SF 2	SF 1	SF 1.5	SF 2			
190-220	779	519	390	1 558	1 039	779	2 337	1 558	1 169	2 921	1 948	1 461	3 311	2 207	1 655	1 800	220	290
220-255	1 340	894	670	2 681	1 787	1 340	4 021	2 681	2 010	5 026	3 351	2 513	5 696	3 798	2 848	1 500	255	365
250-290	1 895	1 264	948	3 791	2 527	1 895	5 686	3 791	2 843	7 107	4 738	3 554	8 055	5 370	4 027	1 300	290	400
280-320	2 775	1 850	1 387	5 550	3 700	2 775	8 325	5 550	4 162	10 406	6 937	5 203	11 793	7 862	5 897	1 200	290	450
320-360	3 351	2 234	1 675	6 702	4 468	3 351	10 052	6 702	5 026	12 565	8 377	6 283	14 241	9 494	7 120	1 000	320	475
360-370	5 445	3 630	2 723	10 890	7 260	5 445	16 335	10 890	8 168	20 419	13 613	10 209	23 141	15 428	11 571	900	360	575

# Availabilities

ESCO proposes a range of couplings available with Exposed Metric (EM) or Exposed Inch (IM) bolts and nuts.

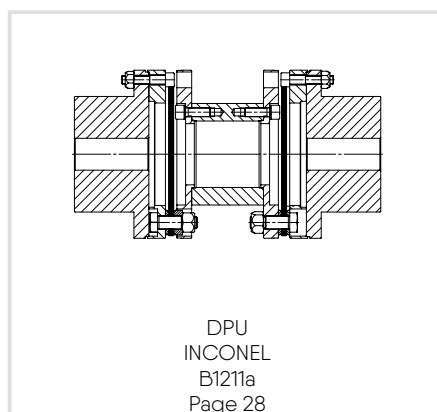
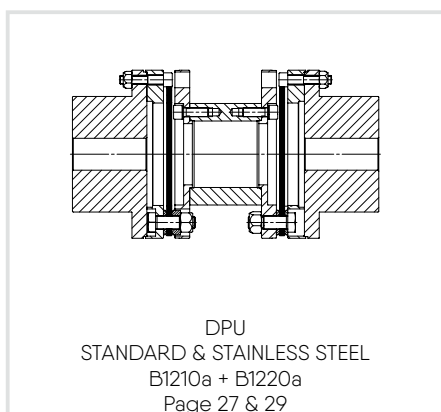
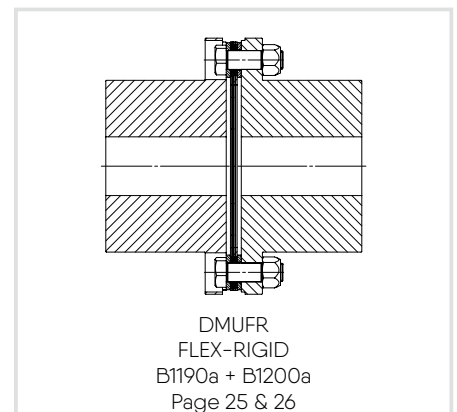
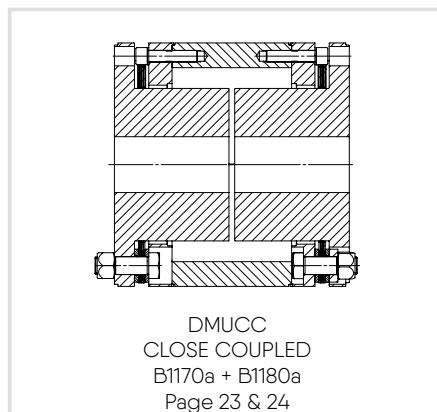
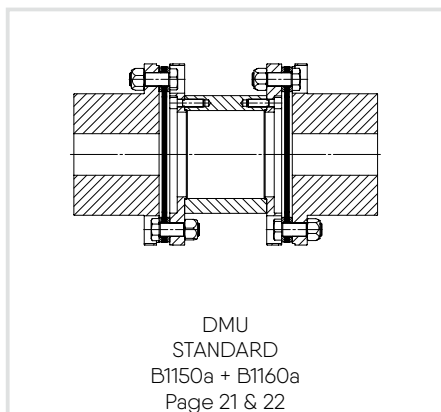
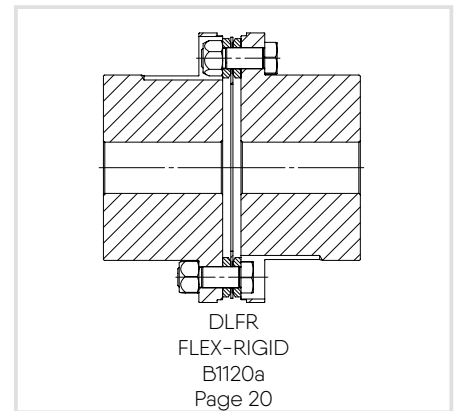
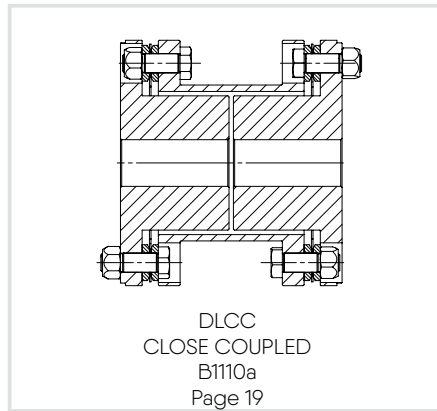
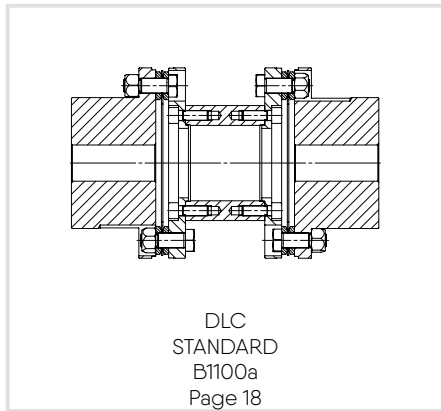

In the follow-up you will find the chapters „Further details and options“ and „Further designs and combinations“ for more information.

## How to select the right coupling size

### Coupling size selection

#### 1. Based on application data

Depending on torque, speed, distance between shaft ends and the shaft sizes of the two machines to be connected, a first selection can be made. DLC couplings are limited in torque and bore capacity so for medium to high torque application DMU or DPU series have to be used. For torques > 231 00 Nm, DMU is preferred. High Speed applications are, thanks to its concept, best covered by the DPU series. For short DBSE application, DLCC or DMUCC can be selected while for long DBSE application (DBSE > 1 000 mm) requiring balancing, ESCODISC DMU or DPU have to be used. In the below table an overview of the coupling characteristics are given for quick selection.

#### 2. Based on specific application requirements

Specific application requirements can also determine the ESCODISC type to be used. These requirements might be balancing, conformity to API specifications, non-sparking execution, special materials, assembly, available space etc...

#### 3. Based on commercial requirements

#### 4. Based on customer standardisation/preference

	DLC	DLCC	DMU	DMUCC	DPU
Torque capacity Nm (1)	1 600	1 600	260 000	19 800	260 000
Bore capacity mm	105	85	370	170	575
Balancing (2)			Q 2.5		Q 2.5
Short DBSE (<50 mm)		Yes		Yes	
Long DBSE (>1 000 mm)			Yes		Yes
Large hub					Yes
Non sparking				Optional	Optional
High speed applications (>3 000 rpm)					Optional
API 610			Yes		Yes
API 671					Optional
Electrical insulation	Optional		Optional		Optional
Limited end float			Optional		Optional
Shear pin overload protection					Optional
Esco torque overload protection					Optional
Overload spacer			Optional		Optional
Vertical execution					Optional

Remarks: (1) Indicated torque capacity is for standard range. Larger sizes are available on request.

(2) Indicated balance degree gives the maximum advisable balance degree. Standard couplings are not balanced.

## 1) Misalignment capacity

ESCODISC coupling can accommodate 3 types of misalignment:

Axial displacement:  
 $d_a$  mm per coupling  
 $\Delta K_a$  = max. axial displacement  
 (see data sheet)

Angular misalignment:  
 $\alpha$  degree per half coupling:  
 $\alpha$  = max. ( $\alpha_1, \alpha_2$ )  
 $\Delta K_w$  = max. angular misalignment  
 (see data sheet)

Offset misalignment:  
 $d_r$  mm per coupling  
 $\Delta K_r$  = max. offset misalignment:  
 (see data sheet) ( $\Delta K_r = S \text{ tg } \Delta K_w$ )

Max. combined misalignment during operation is calculated by using the graph:

or the formula: 
$$\frac{d_a}{\Delta K_a} + \frac{\alpha}{\Delta K_w} + \frac{d_r}{\Delta K_r} \leq 1$$

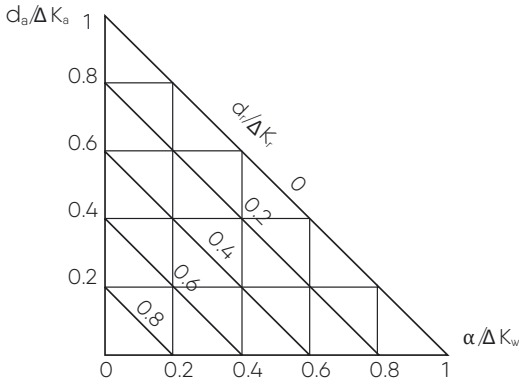

Example:  
 For ESCODISC DMU 65 - 75, max. values given in data sheet are:  
 $\Delta K_a = 2.6$  mm;  $\Delta K_w = 0.5^\circ$ ;  $\Delta K_r = 0.8$  mm.

Check if actual misalignment values are permissible:  
 $d_a = 0.8$  mm;  $\alpha = 0.15^\circ$  and  $d_r = 0.2$  mm

$$\frac{d_a}{\Delta K_a} + \frac{\alpha}{\Delta K_w} + \frac{d_r}{\Delta K_r} = \frac{0.8}{2.6} + \frac{0.15}{0.5} + \frac{0.2}{0.8} = 0.85 \leq 1 \text{ : OK}$$

In case of use in potentially explosive atmospheres  $\text{Ex}$ , European Directive 2014/34/EU (\*\*ATEX) & 1999/92/EC (\*\*ATEX 137) the combination of misalignment may not exceed 0.8.

$$\frac{d_a}{\Delta K_a} + \frac{\alpha}{\Delta K} + \frac{d_r}{\Delta K_r} \leq 0.8$$

At assembly, we however recommend not to exceed 20% of the complete misalignment capacity of the coupling] See installation and maintenance instructions (IM).

## 2) Torque capacity and selection

2.1. Tabulated torques are independent from misalignment and speed conditions as far as combined misalignment is within the specified values (see above) and speed does not exceed tabulated values.

2.2. How to select?

- A. First select the size of ESCODISC coupling that will accommodate the largest shaft diameter.
- B. Make sure this coupling has the required nominal torque capacity according to the formula:

$$\text{Torque in Nm} = \frac{9550 \times P \times F_u \times F_{\text{Ex}}}{n}$$

Where  $P_{\text{Ex}}$  = Power in kW,  $n$  = speed in rpm

$F_u$  = Service factor depending on the connected machine (see below)

$F_{\text{Ex}}$  = 1.5 in case of use in potentially explosive atmospheres  $\text{Ex}$ . In normal atmospheres,  $F_{\text{Ex}} = 1$ .

The coupling selected per A must have an equal or greater nominal torque capacity  $T_n$  (see planographs B1100a to B1220a) than the result of the formula B. If not, select a larger size coupling.

- C. Check that the selected coupling has the required peak torque capacity according to the following formula :

Calculated peak torque = Peak torque of the application  $\times F_{\text{Ex}}$ ;  $F_{\text{Ex}}$ , see above (Point B)

For application with direct starting of an AC motor, the transmitted peak torque has to be calculated with the following formula :

$$\text{Calculated Peak Torque} = 7 \times T \text{ Nm}^x \quad \text{where} \quad T \text{ Nm} = \text{nominal torque of motor (Nm)}$$

$J_1$  = inertia of motor (kgm<sup>2</sup>)

$J_2$  = inertia of the driven machine (kgm<sup>2</sup>)

$F_{\text{Ex}}$  = see above (point B).

For application using a brake, calculated peak torque = brake torque  $\times 1.5 \times F_{\text{Ex}}$ .

Peak torque capacity  $T_p$  of the coupling (see planographs B1100a to B1220a) must be higher than the calculated peak torque. If not, select a larger coupling.

- D. Check if shaft/hub assembly will transmit the torque. (If in doubt, please contact us.)
- E. Read carefully assembly and maintenance instructions (IM).

**Table 1: Service factor ( $F_u$ )**

Service factor depends on coupled machines (driver and driven =  $F_m$ ) and on the working condition ( $F_w$ ).  $F_u = F_m \cdot F_w$

	DRIVER MACHINE	DRIVEN MACHINE
$F_m = F_n$	Electric and hydraulic motors, turbines	See tabulation
$F_m = F_n + 0.4$	Piston engine with 4 cylinders and more	
$F_m = F_n + 0.9$	Piston engine with 1 to 3 cylinders	

$F_w = 1$  for non reversing applications -  $F_w = 1.25$  for reversing applications - for more than 2 starts per min.

DRIVEN MACHINE	$F_n$	DRIVEN MACHINE	$F_n$
<u>Agitators</u>		<u>Handling equipment</u>	
- High inertia* and/or heavy liquids	1.75	- Conveyor	1.75
- Low inertia and light liquids	1	- Crane	2
<u>Compressors</u>		- Elevator	1.5
- Centrifugal	1.5	- Hoist	1.75
- Reciprocating	2.5	<u>Machines - Various</u>	
<u>Generators</u>		- Laundry washer	1.75
- Continuous duty	1	- Packing and bottling	1.5
- Welding	1.75	- Paper and textile	2
<u>Machine tool</u>		- Rubber mill	2
- Auxiliary drivers	1	- Wood and plastic Metallurgy	1.5
- Main drivers	1.75	<u>Metallurgy</u>	
<u>Pumps</u>		- Continuous casting	2.5
- Reciprocating	2.5	- Wood and plastic Metallurgy	2.5
- Gear	1.5	- Shear, Stripmill	2.25
- Centrifugal		<u>Mining, cement, briquetting</u>	
- High inertia* and/or heavy liquids	1.75	- Crusher	3
- Low inertia and light liquids	1	- Mixer (concrete)	1.75
- Propeller	1.25	- Rotating oven	2
- Waterjet pump	1.25	<u>Wire drawing</u>	2
<u>Ventilators, axial or radial blowing</u>			
- Great capacity*, cooling tower	2		
- Low inertia	1		

If  $J_1 < 2J_2$  with  $J_1$  = inertia of electric motor and  $J_2$  = inertia of the driven machine.

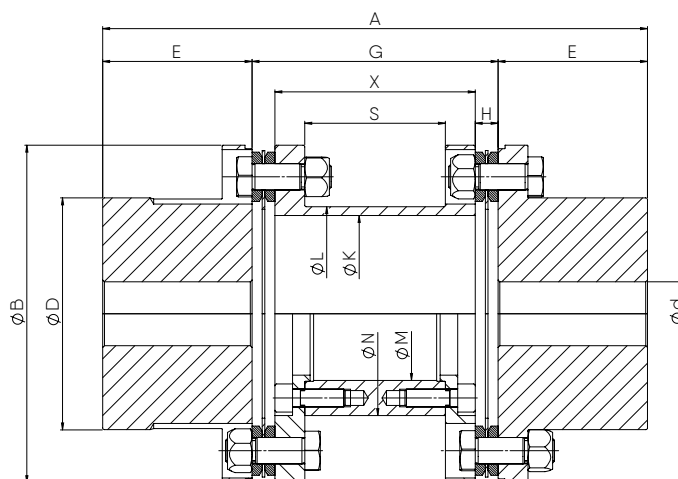

size	torque DLC		n max.	Ød min. (1)	Ød max. (2)	A	ØB	ØD	E	G (3)	H	ØK	ØL	ØM	ØN	S	X	weight (4)	inertia J (4)	max. misalignment		
	nominal T <sub>n</sub>	peak T <sub>p</sub>																		angular	radial	axial (±)
DLC	kNm	kNm	rpm	dimensions in mm														kg	kgm <sup>2</sup>	degree	mm	mm
28-28	0.07	0.125	5 800	0	28	156	76	40	28	100	6.5	30	36	- (*)	- (*)	71	87	1.6	0.001	2x0.75	0.8	1.2
38-45	0.11	0.19	5 000	0	45	170	88	58.5	35	100	6.7	43	49	21	41	70.6	86.6	2.6	0.002	2x0.75	0.8	1.8
45-55	0.2	0.35	5 600	0	55	190	102	69.5	45	100	6.5	54	60	37	61	71	87	4.2	0.004	2x0.5	0.8	1.2
55-65	0.35	0.62	4 600	0	65	200	123	82	50	100	7	67	74	48	72	64	86	7.0	0.01	2x0.5	0.8	1.4
65-75	0.65	1.15	3 900	25	75	220	147	97.5	60	100	9	81	88	54	86	60	82	10.6	0.022	2x0.5	0.8	1.6
75-90	1	1.75	3 500	32	90	240	166	113	70	140	10	96	104	65	98	48	80	16.9	0.048	2x0.5	0.8	2
85-105	1.6	2.8	3 000	38	105	310	192	132	85	140	13	112	122	76	116	80	114	26.9	0.101	2x0.5	1.1	2.4

- (1) Min. finish machine bore diameter
- (2) Max. bore diameter with one keyway acc. DIN 6885/1
- (3) Other lengths are available. Please contact us.
- (4) For pre-bored/unbored hubs
- (\*) Size 28 is not available

- Couplings can be supplied with several options (e.g. puller holes, set screws, ATEX, surface protection)  
→ refer to page 32 et seqq. (B106a et seqq.)
- For the correct coupling selection please refer to page 15 et seqq. (B103a)
- For special executions or requirements, please contact us
- Technical modifications reserved and given values without engagement

DLCC  
CLOSE COUPLED  
28-20 ➤ 85-85

B1110a

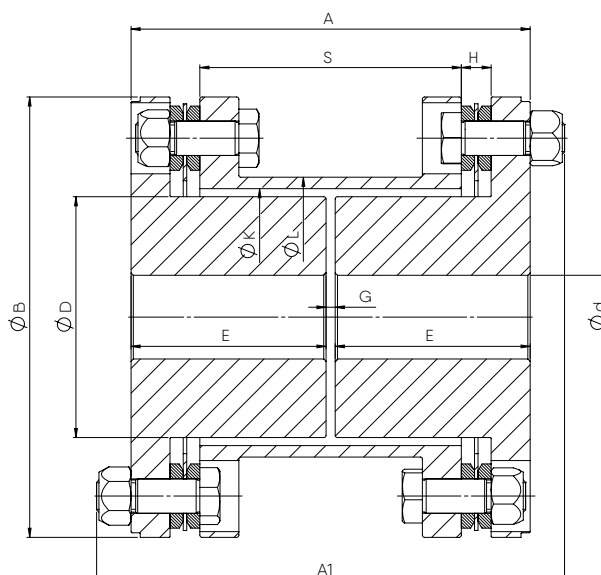

size	torque DLCC		n max.	Ød min. (1)	Ød max. (2)	A	ØB	ØD	E	G (3)	H	K	L	S	A1	weight (4)	inertia J (4)	max. misalignment		
	nominal T <sub>n</sub>	peak T <sub>p</sub>																angular	radial	axial (±)
DLCC	kNm	kNm	rpm	dimensions in mm												kg	kgm <sup>2</sup>	degree	mm	mm
28-20	0.07	0.125	5 800	0	20	116 (66)	76	29	28	60 (10)	6.5	30	36	87 (37)	133 (83)	1.4	0.0008	2x0.75	0.8	1.2
38-28	0.11	0.19	5 000	0	28	116 (73)	88	40	35	46 (3)	6.7	43	49	86.6 (43.6)	133 (90)	2.1	0.002	2x0.75	0.8	1.8
45-40	0.2	0.35	5 600	0	40	116 (93)	102	52	45	26 (3)	6.5	54	60	87 (64)	133 (110)	3.2	0.003	2x0.5	0.8	1.2
55-50	0.35	0.62	4 600	0	50	122 (103)	123	65	50	22 (3)	7	67	74	86 (67)	142 (123)	5.8	0.009	2x0.5	0.8	1.4
65-60	0.65	1.15	3 900	25	60	122	147	78	59	4	9	81	88	82	148	8.5	0.018	2x0.5	0.8	1.6
75-70	1	1.75	3 500	32	70	132	166	92	64	4	10	96	104	80	162	13.5	0.041	2x0.5	0.8	2
85-85	1.6	2.8	3 000	38	85	174	192	108	85	4	13	112	122	114	210	22.1	0.084	2x0.5	1.1	2.4

- (1) Min. finish machine bore diameter
- (2) Max. bore diameter with one keyway acc. DIN 6885/1
- (3) Other lengths are available. Please contact us.
- (4) For pre-bored/unbored hubs

- Couplings can be supplied with several options (e.g. puller holes, set screws, ATEX, surface protection) → refer to page 32 et seqq. (B106a et seqq.)
- For the correct coupling selection please refer to page 15 et seqq. (B103a)
- For special executions or requirements, please contact us
- Technical modifications reserved and given values without engagement

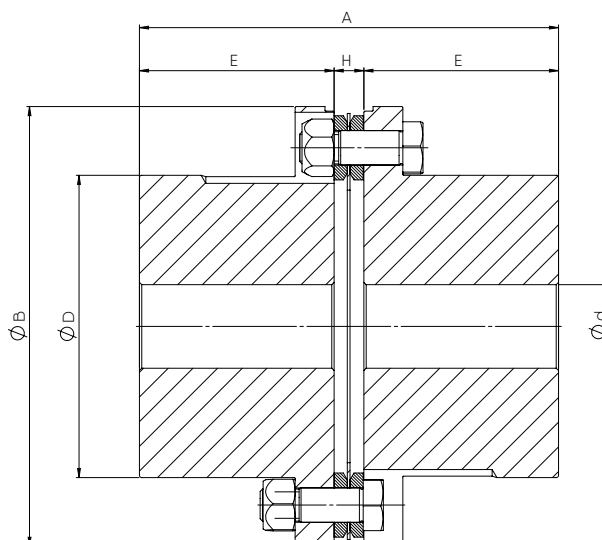
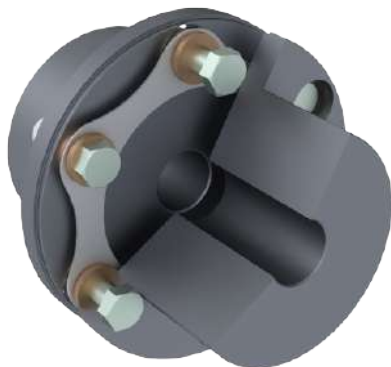

size	torque DLFR		n1 max.	Ød min. (1)	Ød max. (2)	A	ØB	ØD	E	H	weight (3)	inertia J (4)	max. misalignment		
	nominal T <sub>n</sub>	peak T <sub>p</sub>											angular	axial (±)	
DLFR	kNm	kNm	rpm	dimensions in mm								kg	kgm <sup>2</sup>	degree	mm
28-28	0.07	0.125	5 800	0	28	62.5	76	40	28	6.5	1	0.0005	0.75	0.6	
38-45	0.11	0.19	5 000	0	45	76.7	88	58.5	35	6.7	1.9	0.0012	0.75	0.9	
45-55	0.2	0.35	5 600	0	55	96.5	102	69.5	45	6.5	3.2	0.0027	0.5	0.6	
55-65	0.35	0.62	4 600	0	65	107	123	82	50	7	5.3	0.007	0.5	0.7	
65-75	0.65	1.15	3 900	25	75	129	147	97.5	60	9	8.3	0.015	0.5	0.8	
75-90	1	1.75	3 500	32	90	150	166	113	70	10	13.1	0.032	0.5	1	
85-105	1.6	2.8	3 000	38	105	183	192	132	85	13	21	0.068	0.5	1.2	

(1) Min. finish machine bore diameter

(2) Max. bore diameter with one keyway acc. DIN 6885/1

(3) For pre-bored/unbored hubs

- Couplings can be supplied with several options (e.g. puller holes, set screws, ATEX, surface protection)  
→ refer to page 32 et seqq. (B106a et seqq.)
- For the correct coupling selection please refer to page 15 et seqq. (B103a)
- For special executions or requirements, please contact us
- Technical modifications reserved and given values without engagement

Notes:

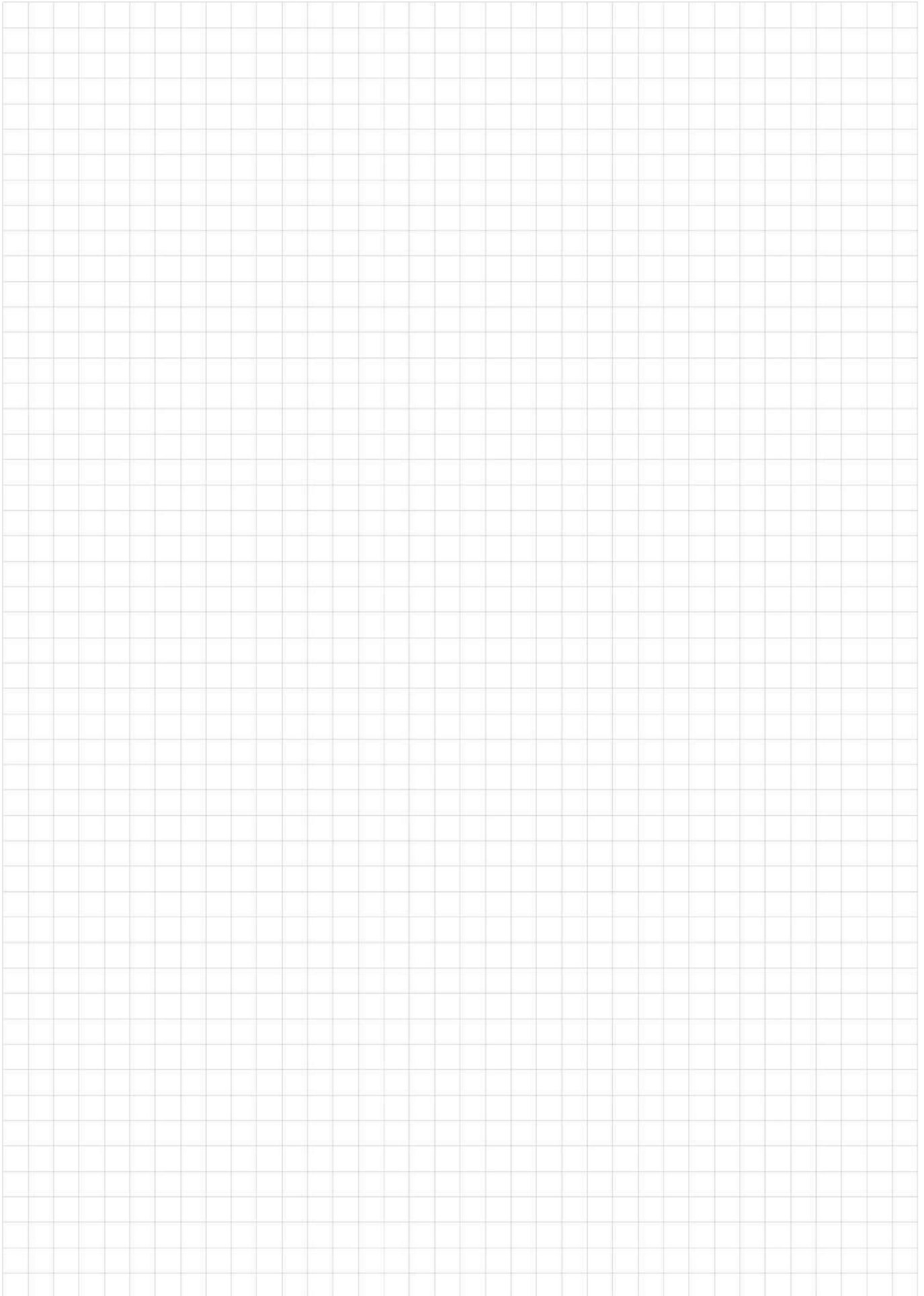

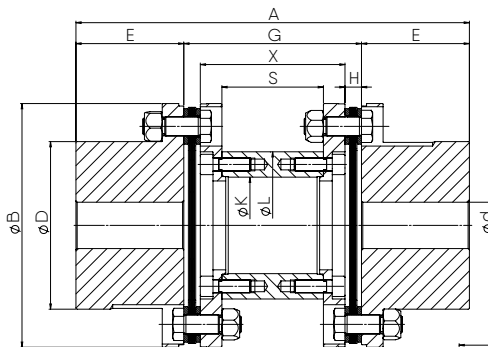

size 38-45 to 85-105

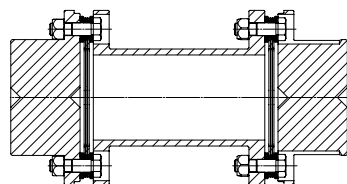

size 28-28

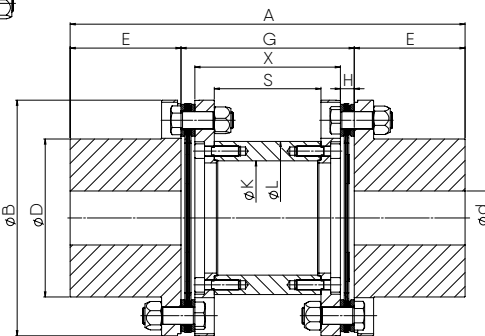

size 95-105 to 160-185

size	torque DMU		n1 max.	n2 max. (1)	Ød min. (2)	Ød max. (3)	A	ØB	ØD	E	G (4)	H	ØK	ØL	S	X	weight (5)	inertia J (5)	max. misalignment		
	nominal Tn	peak Tp																	angular	radial	axial (±)
DMU	kNm	kNm	rpm	rpm	dimensions in mm											kg	kgm <sup>2</sup>	degree	mm	mm	
28-28	0.07	0.125	10 000	20 000	0	28	156	76	40	28	100	6.5	36	41	72	7.25	1.64	0.001	2x0.25	0.4	1.2
38-45	0.19	0.29	8 000	16 000	0	45	170	88	58.5	35	100	6.7	21	41	70.6	86.6	3.1	0.001	2x0.75	0.8	2.4
45-55	0.33	0.5	6 800	13 600	0	55	190	102	69.5	45	100	6.5	37	61	71	87	5.0	0.004	2x0.5	0.8	2.0
55-65	0.75	1.12	6 000	12 000	0	65	200	123	82	50	100	7	48	72	64	86	8.0	0.008	2x0.5	0.8	2.4
65-75	1.33	2.0	5 000	10 000	24	75	220	147	97.5	60	100	9	54	86	60	82	12	0.018	2x0.5	0.8	2.6
75-90	2.2	3.3	4 300	8 600	31	90	280	166	113	70	140	10	65	98	88	120	20	0.040	2x0.5	1.1	3.0
85-105	3.5	5.2	3 600	7 200	37	105	310	192	132	85	140	13	76	116	80	114	31	0.084	2x0.5	1.1	4.0
95-105	5.6	8.4	3 200	6 400	43	105	330	224	133	95	140	14	94	134	76	112	40	0.136	2x0.5	1.1	4.0
110-120	8.0	12.0	2 800	5 600	53	120	400	244	154	110	180	15.5	108	156	103	149	60	0.262	2x0.5	1.4	4.4
125-135	10.9	16.4	2 500	5 000	63	135	430	273	175	125	180	19	123	171	96	142	79	0.434	2x0.5	1.4	5.2
140-160	14.2	21.2	2 300	4 600	63	160	530	303	196	140	250	20	143	191	160	210	116	0.779	2x0.5	2	6.6
160-185	19.8	29.6	2 000	4 000	78	185	570	340	228	160	250	20	165	221	154	210	164	1.44	2x0.5	2	6.8

- (1) Balancing needed
  - (2) Min. finish machine bore diameter
  - (3) Max. bore diameter with one keyway acc. DIN 6885/1
  - (4) Other lengths are available. Please contact us.
  - (5) For pre-bored/unbored hubs
- Couplings can be supplied with several options (e.g. puller holes, set screws, ATEX, surface protection) → refer to page 32 et seqq. (B106a et seqq.)
  - For the correct coupling selection please refer to page 15 et seqq. (B103a)
  - For special executions or requirements, please contact us
  - Technical modifications reserved and given values without engagement

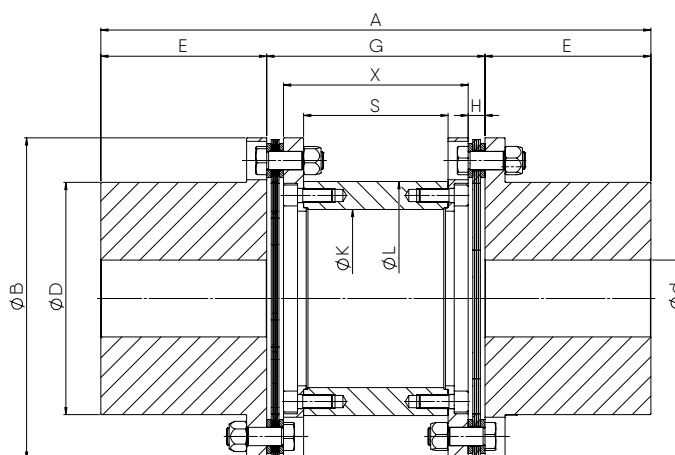

size	torque DMU		n max. (1)	Ød min. (2)	Ød max. (3)	A	ØB	ØD	E	G (4)	H	ØK	ØL	S	X	weight (5)	inertia J (5)	max. misalignment		
	nominal T <sub>n</sub>	peak T <sub>p</sub>																angular	radial	axial (±)
DMU	kNm	kNm	rpm	dimensions in mm												kg	kgm <sup>2</sup>	degree	mm	mm
190-220	30.7	46	1800	90	220	630	383	266	190	250	22	204	268	158	206	222	3	2x0.33	1.4	5
220-255	53	80	1500	120	255	720	445	320	220	280	24.6	254	318	174.8	230.8	358	7.3	2x0.33	1.6	6.6
250-290	93	140	1300	150	290	800	515	350	250	300	38	292	364	160	224	418	11.6	2x0.25	1.3	7.6
280-320	120	180	1200	180	320	900	554	392	280	340	41	314	394	186	258	680	23	2x0.25	1.4	8
320-360	167	250	1050	200	360	1020	604	431	320	380	44.9	330	426	217.2	290.2	916	36	2x0.2	1.3	9
360-370	260	390	900	200	370	1120	704	504	360	400	47.8	432	528	252	332	1400	72	2x0.2	1.4	6

(1) For higher speed please contact us.

(2) Min. finish machine bore diameter

(3) Max. bore diameter with one keyway acc. DIN 6885/1

(4) Other lengths are available. Please contact us.

(5) For pre-bored/unbored hubs

■ Couplings can be supplied with several options (e.g. puller holes, set screws, ATEX, surface protection)  
 → refer to page 32 et seqq. (B106a et seqq.)

■ For the correct coupling selection please refer to page 15 et seqq. (B103a)

■ For special executions or requirements, please contact us

■ Technical modifications reserved and given values without engagement

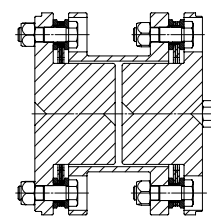
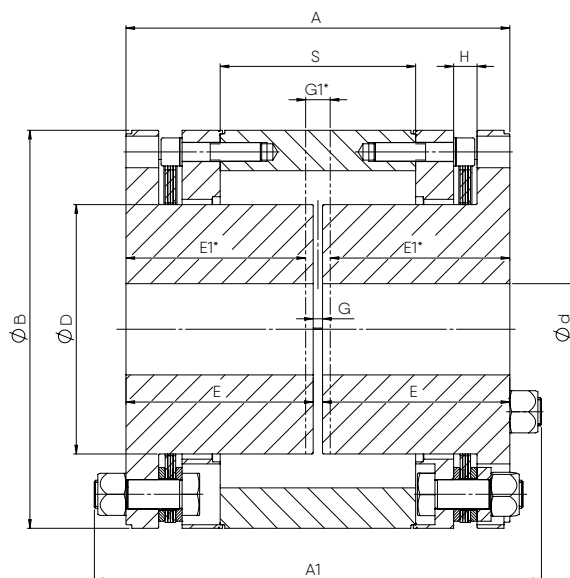
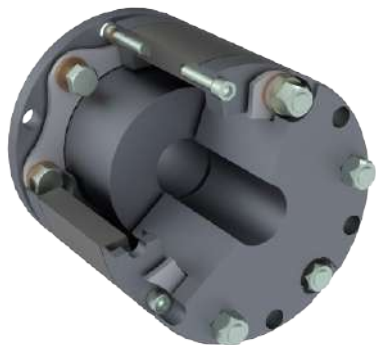

size 28-20

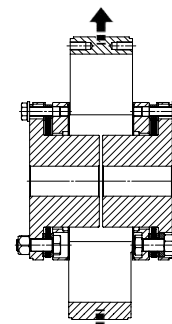

Split spacer

size	torque DMUCC		n1 max.	Ød min. (1)	Ød max. (2)	A	A1	ØB	ØD	E	E1* (3)	G (4)	G1* (3)	H	S	weight (5)	inertia J (5)	max. misalignment			
	nominal Tn	peak Tp																angular	radial	axial (±)	
DMUCC	kNm	kNm	rpm	dimensions in mm													kg	kgm <sup>2</sup>	degree	mm	mm
28-20	0.07	0.125	10 000	0	20	59	65	76	34	28	26	3	7.5	6.5	12	1.37	0.0009	2x0.25	0.19	1	
38-35	0.19	0.29	8 000	0	30	73	87.6	88	40	35	33	3	7.5	6.5	25.6	2.4	0.0024	2x0.75	0.3	2.4	
45-45	0.33	0.5	6 800	0	45	93	108	102	59	45	43	3	7.5	6.5	46	4.52	0.006	2x0.5	0.8	2	
55-50	0.75	1.12	6 000	0	50	103	123	123	70	50	47.5	3	8	7	43	7.57	0.014	2x0.5	0.8	2.4	
65-65	1.33	2	5 000	25	65	122	146	147	84	59	56	4	10	9	54	12.01	0.032	2x0.5	0.8	2.6	
75-75	2.2	3.32	4 300	32	75	132	160	166	97	64	60.5	4	11	10	46	17.42	0.062	2x0.5	0.8	3	
85-90	3.5	5.2	3 600	38	90	174	204	192	112	85	80	4	14	13	76	29.08	0.135	2x0.5	1.1	4	
95-95	5.6	8.4	3 200	45	95	194	230	224	126	95	89.5	4	15	14	88	42.7	0.272	2x0.5	1.1	4	
110-115	8	12	2 800	55	115	226	269	244	151	110	104.8	6	16.5	15.5	98	61.2	0.459	2x0.5	1.4	4.4	
125-130	10.9	16.4	2 500	65	130	256	302	273	166	125	118	6	20	19	117	84.3	0.8	2x0.5	1.4	5.2	
140-140	14.2	21.2	2 300	65	140	286	336	303	182	140	132.5	6	21	20	135	118	1.36	2x0.5	2	6.6	
160-170	19.8	29.6	2 000	80	170	328	382	340	213	160	153.5	8	21	20	167	170	2.5	2x0.5	2	6.8	

- (1) Min. finish machine bore diameter
- (2) Max. bore diameter with one keyway acc. DIN 6885/1
- (3) E1\* and G1\* are min. dimensions to allow disc-pack disassembly without moving the machines
- (4) Other lengths are available. Please contact us.
- (5) For pre-bored/unbored hubs

- Couplings can be supplied with several options (e.g. puller holes, set screws, ATEX, surface protection) → refer to page 32 et seqq. (B106a et seqq.)
- For the correct coupling selection please refer to page 15 et seqq. (B103a)
- For special executions or requirements, please contact us
- Technical modifications reserved and given values without engagement

DMUCC  
CLOSE COUPLED  
190-210 ➤ 360-360

B1180a

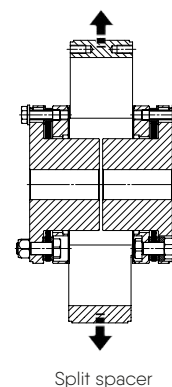
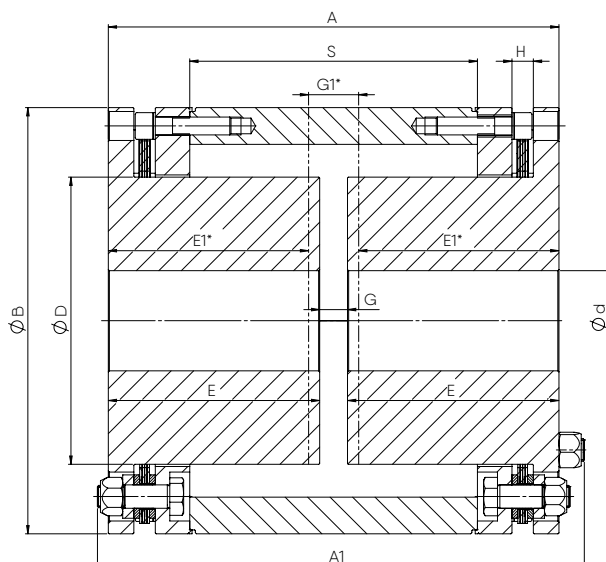

size	torque DMUCC		n1 max. (1)	Ød min. (2)	Ød max. (3)	A	A1	ØB	ØD	E	E1 (4)	G (5)	G1 (4)	H	S	weight (6)	inertia J (6)	max. misalignment			
	nominal Tn	peak Tp																angular	radial	axial (±)	
DMUCC	kNm	kNm	rpm	dimensions in mm													kg	kgm <sup>2</sup>	degree	mm	mm
190-210	30.7	46	1800	90	210	386	431.5	383	258	190	181.5	6	23	22	239.5	259	4.8	2x0.33	1.8	5	
220-255	53	80	1500	120	225	445	508.8	445	282	220	211.2	8	25.6	24.6	248.8	423	11.5	2x0.33	2.1	6.6	
250-244	93	140	1300	150	244	510	590	515	310	250	235.5	10	39	38	306	458	14.8	2x0.25	1.8	7.6	
280-290	120	180	1200	180	290	570	656	554	378	280	264	10	42	41	350	728	30	2x0.25	2	8	
320-320	167	250	1000	200	320	652	732.2	615	410	320	303.1	12	45.9	44.9	398.2	975	48	2x0.2	1.9	9	
360-360	260	390	900	200	360	732	772	704	480	360	341.6	12	48.8	47.8	440.4	1506	89.7	2x0.2	2.1	6	

- (1) For higher speed please contact us.
- (2) Min. finish machine bore diameter
- (3) Max. bore diameter with one keyway acc. DIN 6885/1
- (4) E1\* and G1\* are min. dimensions to allow disc-pack disassembly without moving the machines
- (5) Other lengths are available. Please contact us.
- (6) For pre-bored/unbored hubs

- Couplings can be supplied with several options (e.g. puller holes, set screws, ATEX, surface protection) → refer to page 32 et seqq. (B106a et seqq.)
- For the correct coupling selection please refer to page 15 et seqq. (B103a)
- For special executions or requirements, please contact us
- Technical modifications reserved and given values without engagement

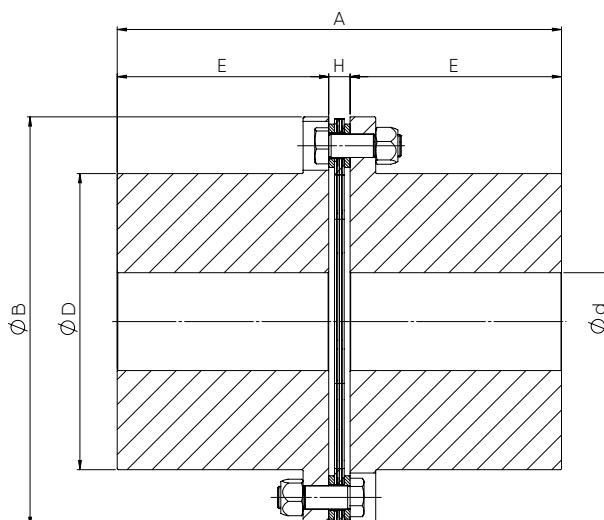

size	torque DMUFR		n1 max.	n2 max. (1)	Ød min. (2)	Ød max. (3)	A	ØB	ØD	E	H	weight (4)	inertia J (4)	max. misalignment		
	nominal T <sub>n</sub>	peak T <sub>p</sub>												rpm	rpm	angular
DMUFR	kNm	kNm	rpm	rpm	dimensions in mm							kg	kgm <sup>2</sup>	degree	mm	mm
28-28	0.07	0.125	10 000	20 000	0	28	62.5	76	40	28	6.5	0.97	0.0005	0.25	0	0.8
38-45	0.19	0.29	8 000	16 000	0	45	76.7	88	58.5	35	6.7	1.91	0.001	0.75	0	1.2
45-55	0.33	0.5	6 800	13 600	0	55	96.5	102	69.5	45	6.5	3.23	0.003	0.5	0	1
55-65	0.75	1.12	6 000	12 000	0	65	107	123	82	50	7	5.31	0.007	0.5	0	1.2
65-75	1.33	2	5 000	10 000	25	75	129	147	97.5	60	9	8.3	0.015	0.5	0	1.3
75-90	2.2	3.32	4 300	8 600	32	90	150	166	113	70	10	13.15	0.032	0.5	0	1.5
85-105	3.5	5.2	3 600	7 200	38	105	183	192	132	85	13	21.13	0.0683	0.5	0	2
95-105	5.6	8.4	3 200	6 400	45	105	204	224	133	95	14	26.21	0.1095	0.5	0	2
110-120	8	12	2 800	5 600	55	120	235.5	244	154	110	15.5	38.94	0.2035	0.5	0	2.2
125-135	10.9	16.4	2 500	5 000	65	135	269	273	175	125	19	54.3	0.3493	0.5	0	2.6
140-160	14.2	21.2	2 300	4 600	65	160	300	303	196	140	20	77.35	0.601	0.5	0	3.3
160-185	19.8	29.6	2 000	4 000	80	185	340	340	228	160	20	113.6	1,136	0.5	0	3.4

- (1) Min. finish machine bore diameter
- (2) Max. bore diameter with one keyway acc. DIN 6885/1
- (3) Other lengths are available. Please contact us.
- (4) For pre-bored/unbored hubs

- Couplings can be supplied with several options (e.g. puller holes, set screws, ATEX, surface protection) → refer to page 32 et seqq. (B106a et seqq.)
- For the correct coupling selection please refer to page 15 et seqq. (B103a)
- For special executions or requirements, please contact us
- Technical modifications reserved and given values without engagement

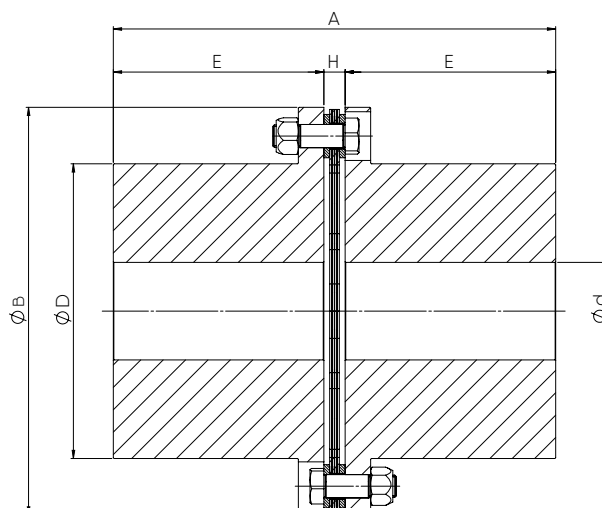
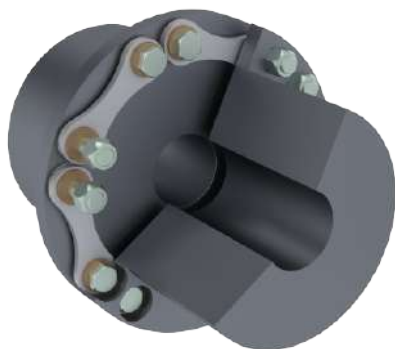

size	torque DMUFR		n1 max. (1)	$\varnothing d$ min. (2)	$\varnothing d$ max. (3)	A	$\varnothing B$	$\varnothing D$	E	H	weight (4)	inertia J (4)	max. misalignment		
	nominal Tn	peak Tp											angular	axial ( $\pm$ )	
DMUFR	kNm	kNm	rpm	dimensions in mm								kg	kgm <sup>2</sup>	degree	mm
190-220	30.7	46	1800	90	220	402	383	266	190	22	168	1.97	2x0.33	5	
220-255	53	80	1500	120	255	465	445	320	220	24.6	279	4.93	2x0.33	6.6	
250-290	93	140	1300	150	290	538	515	350	250	38	381	8.98	2x0.25	7.6	
280-320	120	180	1200	180	320	601	554	392	280	41	505	14.5	2x0.25	8	
320-360	167	250	1050	200	360	685	604	431	320	44.9	685	23.5	2x0.2	9	
360-370	260	390	900	200	370	768	704	504	360	47.8	1089	47.7	2x0.2	6	

- (1) For higher speed please contact us.
- (2) Min. finish machine bore diameter
- (3) Max. bore diameter with one keyway acc. DIN 6885/1
- (4) For pre-bored/unbored hubs

- Couplings can be supplied with several options (e.g. puller holes, set screws, ATEX, surface protection)  
→ refer to page 32 et seqq. (B106a et seqq.)
- For the correct coupling selection please refer to page 15 et seqq. (B103a)
- For special executions or requirements, please contact us
- Technical modifications reserved and given values without engagement

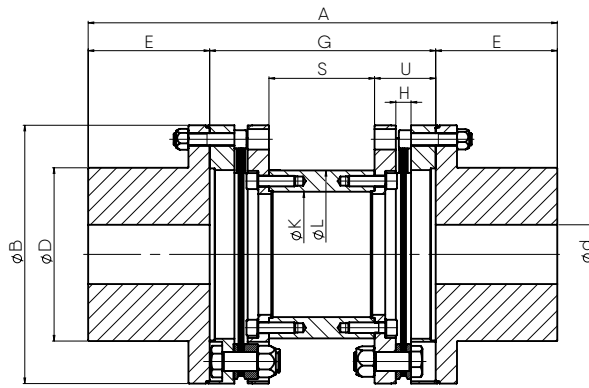

DPUSS 38-60 to 160-220

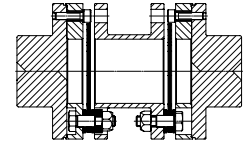

DPUSS 28-45

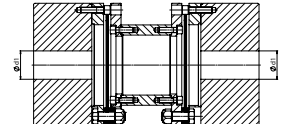

DPULL 38-60 to 160-220

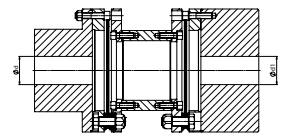

DPUSL 38-60 to 160-220

size	torque DPU (std. material)		torque DPU (AISI 301) (1)		n1 max.	n2 max.	S Hub		L Hub		A	ØB	ØD	E	G (4)	H	ØK	ØL	S	U	weight (5)	inertia J (5)	max. misalignment (std. material & AISI 301)			
	nominal T <sub>n</sub>	peak T <sub>p</sub>	torque T <sub>n</sub>	peak T <sub>p</sub>			Ød min. (2)	Ød max. (3)	Ød min. (2)	Ød max. (3)													angular	radial	axial (±)	
DPU	kNm	kNm	kNm	kNm	rpm	rpm	dimensions in mm															kg	kgm <sup>2</sup>	degree	mm	mm
28-45	0.070	0.125	0.035	0.070	10 000	25 000	0	28	0	45	126	76	40	28	70	6.5	36	41	24.5	22.75	1.89	0.001	2x0.25	0.2	0.8	
38-60	0.190	0.290	0.095	0.190	8 000	24 000	0	45	0	60	170	88	58.5	35	100	7.1	21	41	51.8	24.1	3.54	0.003	2x0.75	0.6	2.4	
45-70	0.330	0.500	0.165	0.330	6 800	20 400	0	55	0	70	190	102	69.5	45	100	6.5	37	61	53	23.5	5.49	0.006	2x0.5	0.6	2.0	
55-80	0.750	1.12	0.375	0.750	6 000	18 000	0	65	0	80	200	123	82	50	100	7	48	72	40	30	9.07	0.015	2x0.5	0.6	2.6	
65-100	1.33	2.00	0.665	1.33	5 000	15 000	25	75	25	100	260	147	97.5	60	140	9	54	86	72	34	15	0.033	2x0.5	0.9	2.8	
75-110	2.20	3.32	1.10	2.20	4 300	12 900	32	90	32	110	280	166	113	70	140	10	65	98	54	43	23	0.070	2x0.5	0.8	3.2	
85-130	3.50	5.20	1.75	3.50	3 600	10 800	38	105	38	130	350	192	132	85	180	13	76	116	82	49	37	0.145	2x0.5	1.1	4.0	
95-145	6.65	10.0	3.33	6.65	3 200	9 600	45	105	45	145	370	224	133	95	180	14	94	134	74	53	47	0.259	2x0.33	1.0	2.5	
110-160	9.35	14.0	4.68	9.35	2 800	8 400	55	120	55	160	470	244	154	110	250	15.5	108	156	122	64	72	0.475	2x0.33	1.4	2.8	
125-180	12.7	19.1	6.35	12.7	2 500	7 500	65	135	65	180	500	273	175	125	250	19	123	171	111	69.5	94	0.775	2x0.33	1.4	2.6	
140-200	16.6	24.9	8.30	16.6	2 300	6 900	65	160	65	200	530	303	196	140	250	20	143	191	99	75.5	128	1.30	2x0.33	1.4	3.0	
160-220	23.1	34.7	11.6	23.1	2 000	6 000	80	185	80	220	570	340	228	160	250	20	165	221	89	80.5	179	2.39	2x0.33	1.4	3.4	

(1) Torque execution for coupling made of stainless steel AISI 301 material

(2) Min. finish machine bore diameter

(3) Max. bore diameter with one keyway acc. DIN 6885/1

(4) Other lengths are available. Please contact us.

(5) For pre-bored/unbored hubs

■ Couplings can be supplied with several options (e.g. puller holes, set screws, ATEX, surface protection, Non-sparking, Anti-flying, cold environment -50° {made of 25CrMo4 material}) → refer to page 32 et seqq. (B106a et seqq.)

■ For the correct coupling selection please refer to page 15 et seqq. (B103a)

■ For special executions or requirements, please contact us

■ Technical modifications reserved and given values without engagement

DPU  
CORROSIVE ENVIRONMENT\* (INCONEL 625/MONEL)

28-45 ➤ 160-220

B1211a

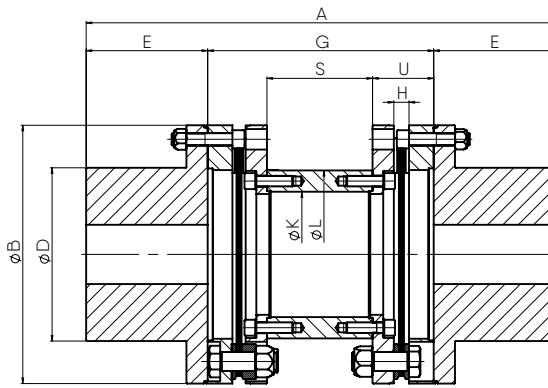

DPUSS 38-60 to 160-220

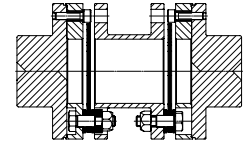

DPUSS 28-45

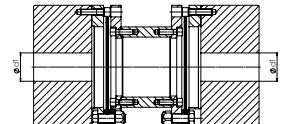

DPULL 38-60 to 160-220

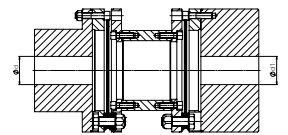

DPUSL 38-60 to 160-220

size	torque DPU (Inconel)		n1 max.	n2 max.	S Hub		L Hub		A	ØB	ØD	E	G (3)	H	K	L	S	U	weight (4)	inertia J (4)	max. misalignment (Inconel)				
	nominal Tn	peak Tp			Ød min. (1)	Ød max. (2)	Ød min. (1)	Ød max. (2)													angular	radial	axial (±)		
DPU	kNm	kNm	rpm	rpm	dimensions in mm																kg	kgm <sup>2</sup>	degree	mm	mm
28-45	0.070	0.125	10 000	25 000	0	28	0	45	126	76	40	28	70	71	36	41	23.3	23.4	1.89	0.001	2x0.17	0.65	0.26		
38-60	0.190	0.290	8 000	24 000	0	45	0	60	170	88	58.5	35	100	8.0	21	41	50	25.0	3.54	0.003	2x0.50	0.65	0.40		
45-70	0.330	0.500	6 800	20 400	0	55	0	70	190	102	69.5	45	100	7.1	37	61	52	24.1	5.49	0.006	2x0.33	0.44	0.35		
55-80	0.750	1.12	6 000	18 000	0	65	0	80	200	123	82	50	100	8.0	48	72	38	31	9.07	0.015	2x0.33	0.39	0.45		
65-100	1.33	2.00	5 000	15 000	24	75	25	100	260	147	97.5	60	140	8.9	54	86	72	34	15	0.033	2x0.33	0.59	0.40		
75-110	2.20	3.32	4 300	12 900	30.5	90	32	110	280	166	113	70	140	10	65	98	54	43	23	0.070	2x0.33	0.55	0.50		
85-130	3.50	5.20	3 600	10 800	36.5	105	38	130	350	192	132	85	180	14	76	116	80	50	37	0.145	2x0.33	0.74	0.70		
95-145	6.65	10.0	3 200	9 600	43	105	45	145	370	224	133	95	180	15	94	134	72	54	47	0.259	2x0.20	0.43	0.40		
110-160	9.35	14.0	2 800	8 400	53	120	55	160	470	244	154	110	250	16.5	108	156	120	65	72	0.475	2x0.20	0.64	0.45		
125-180	12.7	19.1	2 500	7 500	63	135	65	180	500	273	175	125	250	20	123	171	109	70	94	0.775	2x0.20	0.61	0.45		
140-200	16.6	24.9	2 300	6 900	63	160	65	200	530	303	196	140	250	21	143	191	97	77	128	1.30	2x0.20	0.59	0.50		
160-220	23.1	34.7	2 000	6 000	78	185	80	220	570	340	228	160	250	21	165	221	87	82	179	2.39	2x0.25	0.72	0.55		

(1) Min. finish machine bore diameter

(2) Max. bore diameter with one keyway acc. DIN 6885/1

(3) Other lengths are available. Please contact us.

(4) For pre-bored/unbored hubs

\* Only flexible elements (discs) made of Inconel 625/Monel material

■ Couplings can be supplied with several options (e.g. puller holes, set screws, ATEX, surface protection, Non-sparking, Anti-flying, major parts {hubs, spacer, flanges} can be provided galvanized) → refer to page 32 et seqq. (B106a et seqq.)

■ For the correct coupling selection please refer to page 15 et seqq. (B103a)

■ For special executions or requirements, please contact us

■ Technical modifications reserved and given values without engagement

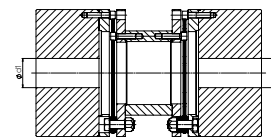
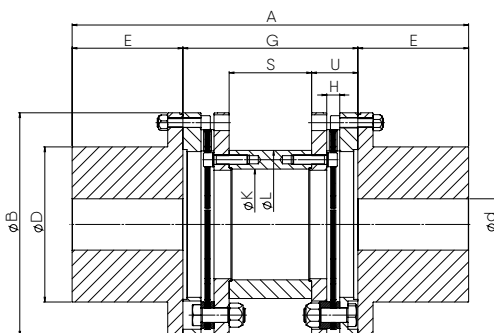

DPULL

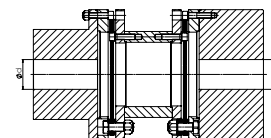

DPUSL

size	torque DPU		n1 max. (1)	n2 max. (2)	S Hub		L Hub		A	ØB	ØD	E	G (5)	H	K	L	S	U	weight (6)	inertia J (6)	max. misalignment		
	nominal Tn	peak Tp			Ød min. (3)	Ød max. (4)	Ød min. (3)	Ød max. (4)													angular	radial	axial (±)
DPU	kNm	kNm	rpm	rpm	dimensions in mm														kg	kgm <sup>2</sup>	degree	mm	mm
190-290	372	55.8	1800	5 400	90	220	90	290	630	383	266	190	250	22	190	254	81.5	84.25	261	4.1	2x0.33	1.19	5
220-365	64	96	1500	4 500	120	255	120	365	720	465	320	220	280	24.6	224	296	592	110.4	478	11	2x0.33	1.36	6.6
250-400	90.5	135.75	1300	3 900	150	290	150	400	800	515	350	250	300	38	292	364	58	121	460	15	2x0.25	1 105	7.6
280-450	132.5	198.75	1200	3 600	180	290	180	450	900	578	392	280	340	41	314	397	79	130.5	763	28	2x0.25	1.19	8
320-475	160	240	1 000	3 000	180	320	180	475	1 020	604	431	320	380	44.9	330	426	81.3	149.35	900	40	2x0.2	1 105	9
360-575	260	390	900	2 700	200	360	200	575	1 150	704	504	360	400	478	380	480	90.6	169.7	1 400	80	2x0.2	1.19	6

(1) For higher speed please contact us.

(2) Balancing is needed

(3) Min. finish machine bore diameter

(4) Max. bore diameter with one keyway acc. DIN 6885/1

(5) Other lengths are available. Please contact us.

(6) For pre-bored/unbored hubs

- Couplings can be supplied with several options (e.g. puller holes, set screws, ATEX, surface protection, Non-sparking, Anti-flying, cold environment -50° {made of 25CrMo4}) → refer to page 32 et seqq. (B106a et seqq.)
- For the correct coupling selection please refer to page 15 et seqq. (B103a)
- For special executions or requirements, please contact us
- Technical modifications reserved and given values without engagement

Notes:

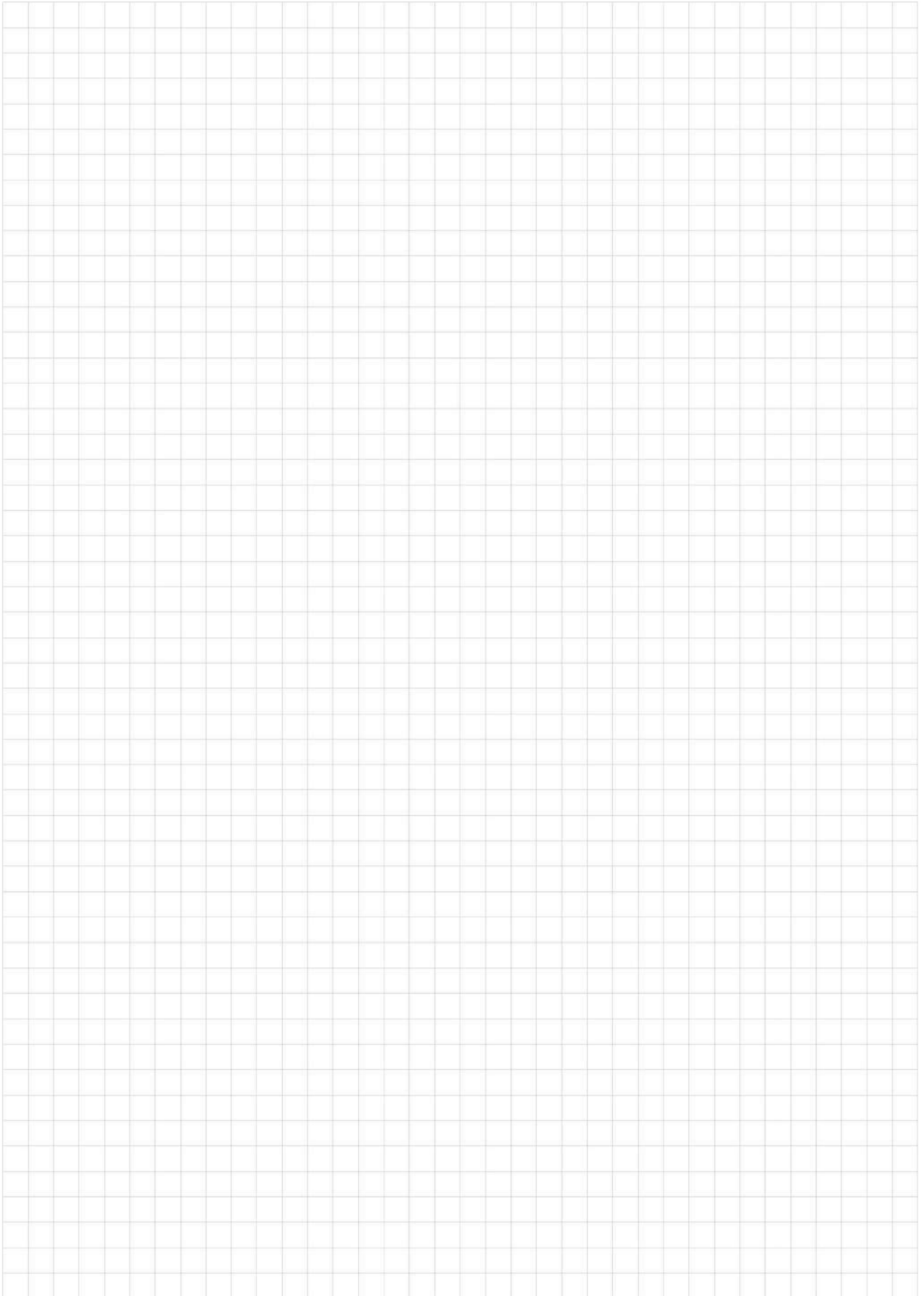

Further details and options

Puller holes and set screw

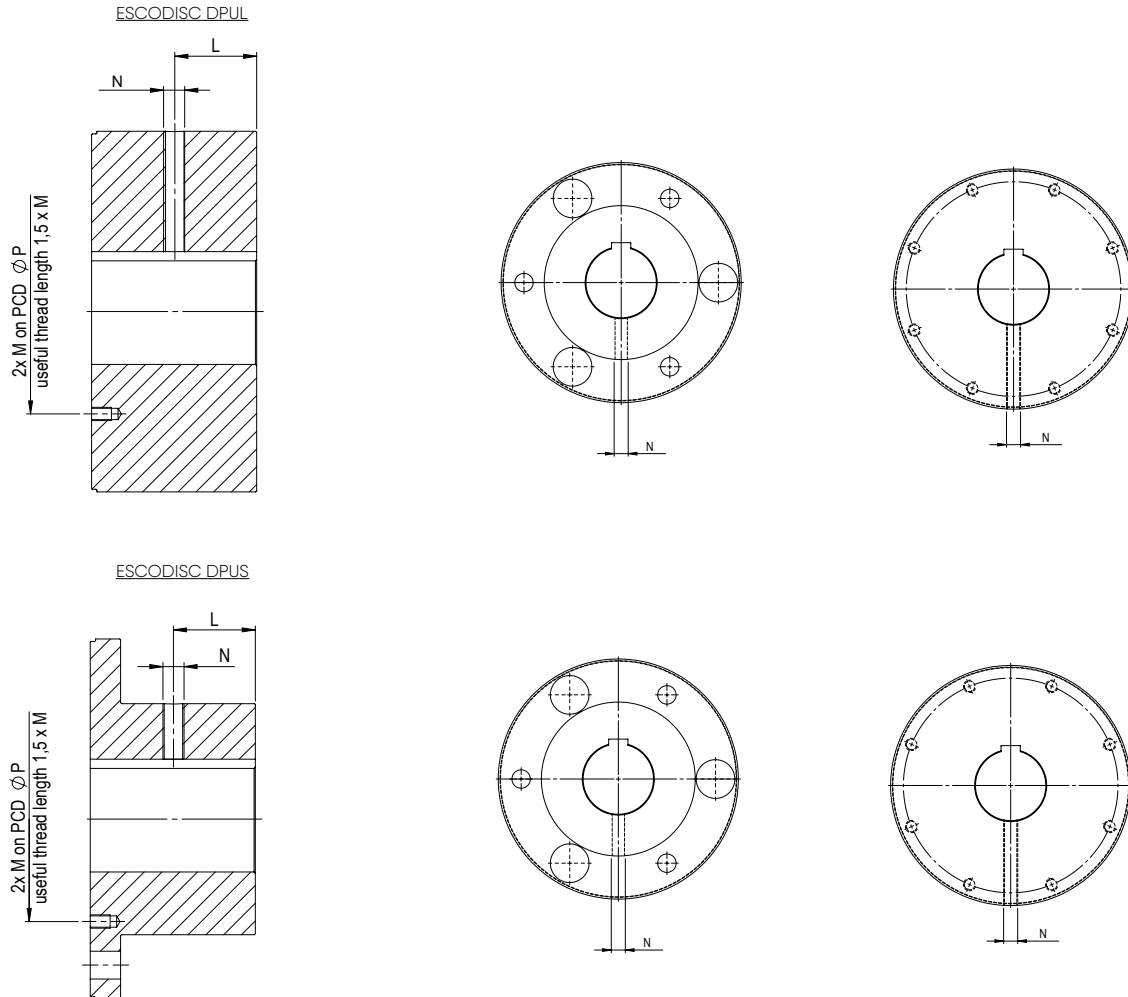

Size (1)	ØD	Set screw (mm)				Puller holes (mm)			
		Size DIN 916		max. bore Ø		Puller holes		max. bore Ø	
		N	L	on shaft	on key	M	P	without puller holes	with puller holes
28	40	M5x5	14	28	24	M5	32	28	22
38	58.5	M6x6	17	45	40	M5	50.5	45	42
45	69.5	M8x8	22	55	45	M5	60	55	50
55	82	M8x8	25	65	55	M6	72	65	60
65	97.5	M10x10	30	75	65	M6	87	75	75
75	113	M10x10	35	90	80	M6	102	90	90
85	132	M12x12	42	105	95	M8	116	105	100
95	133	M12x12	47	105	95	M8	117	105	100
110	154	M16x16	55	120	110	M10	135	120	115
125	175	M16x16	62	135	130	M10	155	135	135
140	196	M16x16	70	160	145	M10	176	160	145
160	228	M20x20	80	185	170	M12	204	185	170

(1) for sizes above 160 please consult us.

## Further details and options

### Balancing

#### 1. Balancing requirements

The actual requirement for balancing of a coupling depends amongst other on:

- Manufacturing quality of the coupling (Natural Inherent Balance Quality)
- Application speed
- The mass of the coupling (relative to the masses of the machine rotors)
- Distance between shaft ends
- Sensitivity of the system thanks to their high manufacturing quality, escodisc couplings have a high degree of natural inherent balance and generally don't require additional balancing for normal speed applications.

Up to size 95, escodisc DLC/DMU/DPU couplings have a minimum balance quality of Q6.3 at 1 500 rpm. For larger sizes, Q6.3 is guaranteed without any additional balancing until 1 000 rpm.

In the below graph you can find when additional balancing is required based on application speed and DBSE. Also you can find the maximum limits for high speed/long DBSE applications based on the coupling size. Above these limits, please contact us. For applications requiring additional balancing, the use of DLC couplings is not recommended.

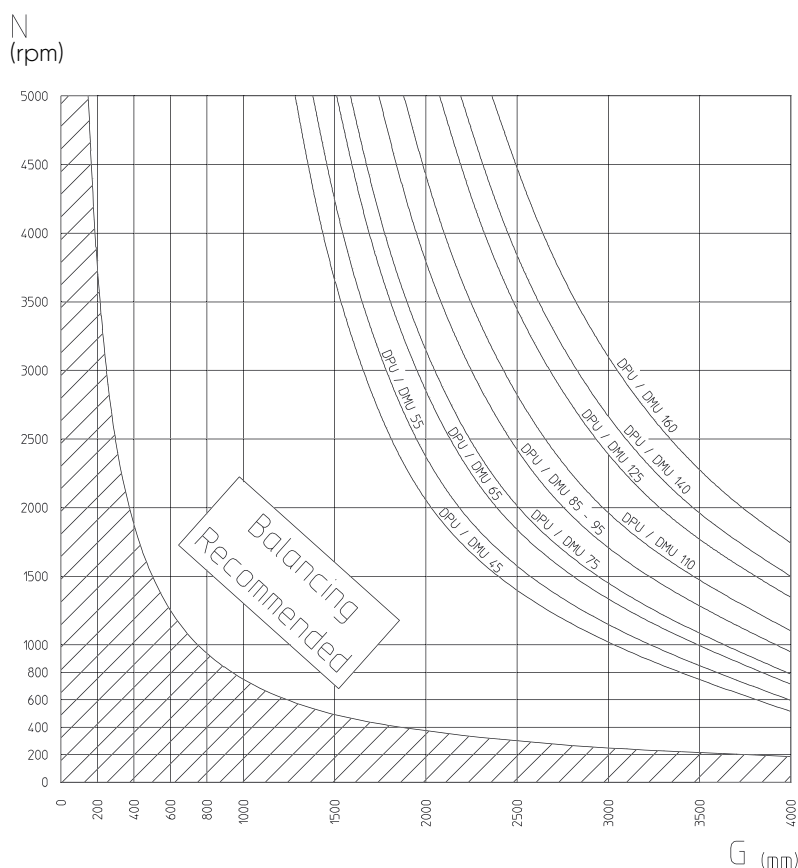

#### 2. ESCO balancing procedures

Based on the application data or specific customer requirements, Esco transmissions will perform a component balancing to Q6.3 or Q2.5 (as specified - Q1 is obtainable yet not advisable for standard couplings) for standard couplings and a component balancing followed by an assembly balancing procedure for high speed applications. Esco transmissions will also perform balancing before the keyway, if any, is shaped in the coupling. Other balancing options are of course available upon request but must be clearly specified when ordering.

Remark: for DMU couplings, only component balancing is possible.

## Shaft connection

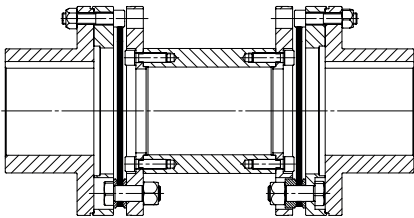

BORE &amp; KEYWAY

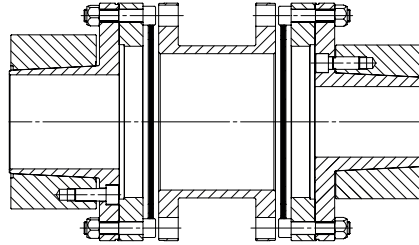

CLAMPING HUB

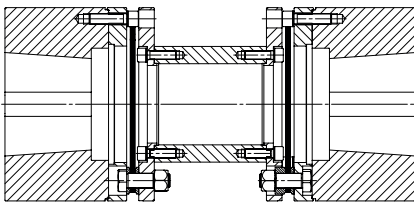

CONICAL BORE

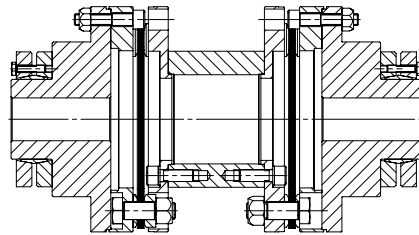

EXTERNAL CLAMPING

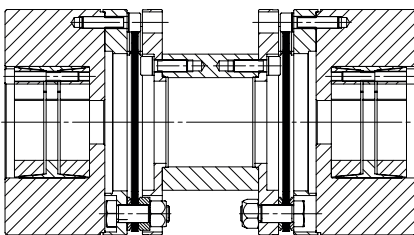

INTERNAL CLAMPING

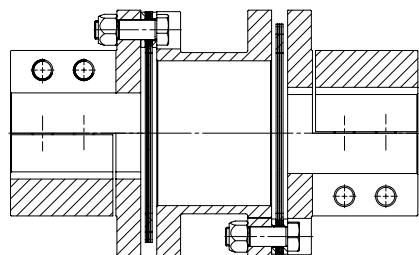

SPLIT HUB

## Protection

Coupling parts up to size 360 are black oxidized by default.  
 Fitted bolts and screws are GEOMET 500 coated and nuts zinc plated.  
 Additional black oxide or special paintings can be done on requests.

## Further designs and combinations

All ESCODISC couplings can be combined and extended almost without limit.  
Please contact us for further details.

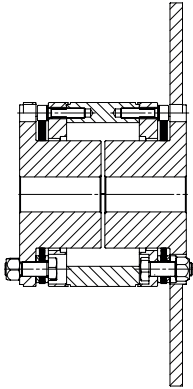

DMUCCBD  
WITH INTEGRATED BRAKE DISC

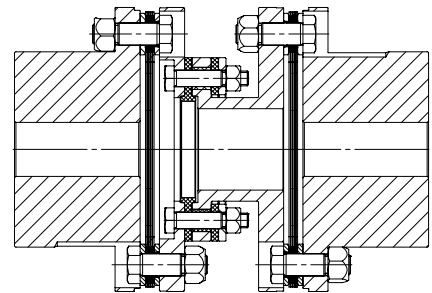

DMUIN  
ELECTRICALLY INSULATED

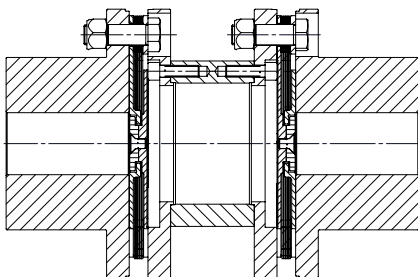

DMULE  
LIMITED END FLOAT

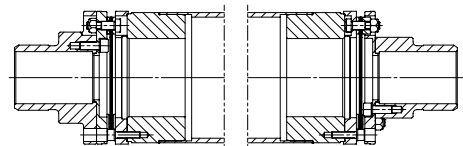

DPUEDSS  
EXTENDED DIAMETER

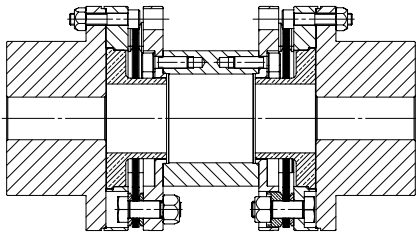

DPUNSAF  
NON-SPARKING ANTI-FLYING

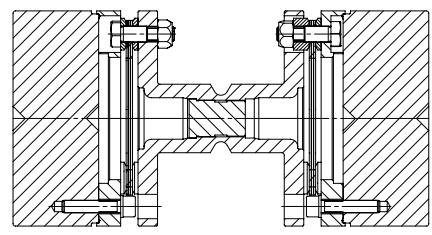

DPUOS  
OVERLOAD SPACER

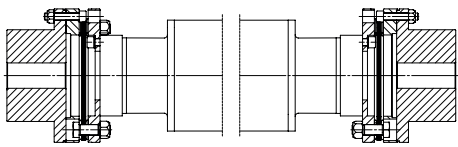

DPUSSCP  
WITH COMPOSITE SPACER

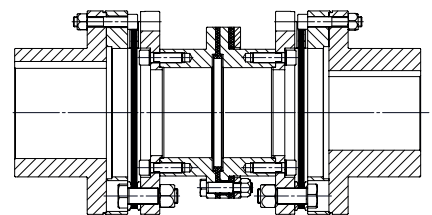

DPUSSIN  
ELECTRICALLY INSULATED

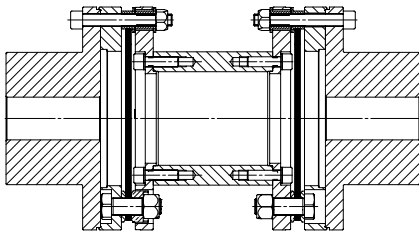

DPUSLE  
LIMITED END FLOAT

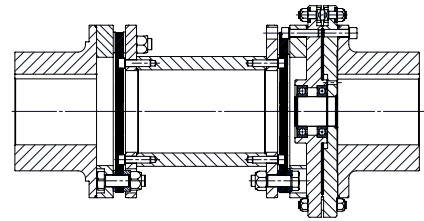

DPUSSP  
SHEAR PIN OVERLOAD PROTECTION

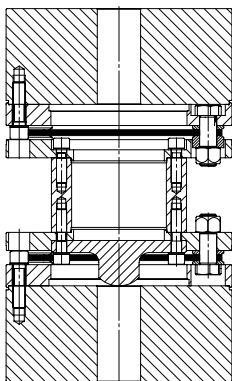

DPUV  
VERTICAL EXECUTION

# Installation and maintenance

## DLC series

### 1) Introduction

Coupling must be selected properly according to selection chart B103a, B104a and B105a and corresponding charts (B1100a, B1110a and B1120a).

These documents are available in coupling catalogue ESCO-DISC or on our web site « [www.escocoupling.com](http://www.escocoupling.com) ». Maximum misalignment figures at assembly are given in this document (see point 4: assembly). Max misalignment figures in operation (combination of radial, angular and axial) are given in ESCODISC catalogue. Max misalignment values may not be applied simultaneously as mentioned in selection chart B104a.

In case of any change or adaptation not performed by ESCO on the coupling, it is customer responsibility to size and manufacture it properly to guarantee safe torque transmission and absence of unbalance that could affect the life of the coupling and the connected machines.

It is customer responsibility to make sure that shaft and key material, size and tolerance suit the application. Maximum bore capacity is given in the catalogue.

If key assembly is not calculated and machined by ESCO, it is customer responsibility to make sure that hub length, bore size and machining tolerances will transmit the torque. If interference fit is not calculated and machined by ESCO, it is customer responsibility to make sure that interference and machining tolerances will transmit the torque and not exceed hub material permissible stress.

The hubs must be axially secured on the shaft by means of a setscrew, an end plate or a sufficient interference. In case of spacer not supplied by ESCO, it is customer responsibility to size and manufacture it properly to guarantee safe torque transmission and absence of unbalance that could affect the life of the Discs. It is customer responsibility to protect the coupling by p.ex. a coupling guard and to comply with the local safety rules regarding the protection of rotating parts.

### 2) Preparation

Ensure the conformity of the supplied equipment:

- Verify coupling size and conformity (see catalogue or web site).
- Identify any damaged and/or missing parts.
- Verify conformity of the coupling/machine interfaces.
- Coupling original protection allows for storage indoors dry 18 months, indoors humid 12 months, outdoors covered : 9 months and outdoors open 3 months. For longer periods, it is customer responsibility to protect the parts properly.
- Instructions are a part of the supply of the coupling. Be sure valid and complete assembly, operation and maintenance instructions are available. Make sure they are well understood. In case of doubt, refer to ESCO.

Assembly, disassembly and maintenance must be performed by qualified, trained and competent fitters.

Before starting with assembly, disassembly and maintenance, verify the availability of the tooling necessary

- To manipulate the parts
- To assemble the interfaces
- To align the coupling
- To tighten the screws and nuts

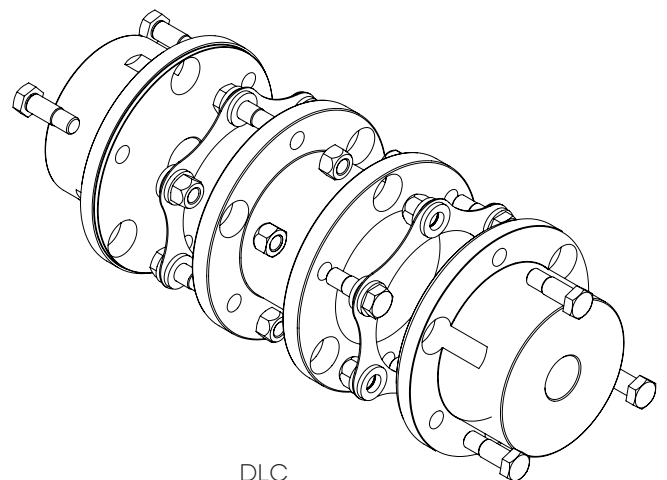

DLC

## 3) Warnings

Before removing the coupling guard and proceeding with any assembly, operation or maintenance operation of the coupling, make sure the complete system is completely shut down and definitively disengaged from any possible source of rotation, such as, for example :

- Electrical power supply
- Any loss of braking effect

Make sure everyone attending the equipment area will be properly informed (for example by means of warnings properly located) about the maintenance or assembly situation.

**In case of use in explosive atmosphere  $\text{Ex}$ , specific protective measures must be considered. They are described in an extra attachment (IM/A100a-Ex) to the actual instructions with, the couplings marked  $\text{Ex}$ .**

## 4) Assembly DLC couplings

### 4.0. Warning

4.0.1. The hubs (1) and the spacer (3) are supplied unassembled. The discs (2) are supplied packed with the screws and nuts (4) under plastic film to ensure a perfect protection. They will only be unpacked during final mounting on the machine.

4.0.2. If coupling is supplied rough bored, bore and keyway must be machined in hubs (1). When machining the bore, surface marked (M) must be taken as the turning reference.

### 4.1. Assembly

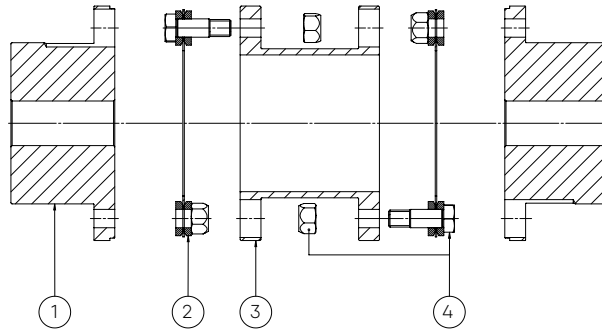

4.1.1. Ensure that parts are clean and mount the hubs (1) in the correct position on the shafts of the machines (the flange at the shaft end for the DLC Series, the flange at the machine side for the DLCC Series). Hub faces must be flush with shaft end. In case of doubt, please consult us. Introduce setscrew on key with Loctite and tighten properly. In case of interference fit, refer to ESCO for proper instructions.

4.1.2. Position the machines to be connected (for DLCC Series, the spacer (3) and the discs (2) must be placed on the hubs (1) during the installation, see also point 4.1.4 and check distance G between the hubs (for the DLCC Series, check also distance A). See tabulation 1 or approved drawing for distance G following type of coupling. In case of doubt, please consult us.

4.1.3. Align the shafts using an indicator. The alignment precision (X, Y - Z) is given in the tabulation 1.

4.1.4. Ensure that the flanges of the hubs (1) and the spacer (3) are perfectly degreased. Unpack the discs and the screws. Mount the disc (2) on one hub (1) with screws

and nuts (4) in the direction shown on the fig. 2 Tighten to torque T while holding the screws still and turning the nuts. See tabulation 1 for tightening torque (T Nm) and socket size (s mm).

4.1.5. Install the spacer (3) between the hubs and connect it to the already assembled disc (2) with screws and nuts (4), in the direction shown on the fig. 3 (in case of long spacer, it is essential to support the spacer in position from the beginning to the end of the assembly). Tighten to torque T mentioned while holding the screws still and turning the nuts. See tabulation 1 for tightening torque (T Nm) and socket size (s mm).

4.1.6. Engage the second disc (2) between the spacer (3) and the second hub (1) and assemble with screws and nuts (4) as indicated in fig. 4.

4.1.7. Check once again the alignment by measuring the max. value H1 and the min. value H2 of the distance between the hub flange and the spacer flange (see fig. 5). See tabulation 1 for the permissible values.

## 5) Operation, inspection and maintenance

### 5.0. Operation and maintenance

5.0.1 No maintenance is necessary. It is however recommended to verify the alignment (see point 4.1.7) and the tightening torque of the screws and nuts (4) (see tabulation 1) after the first running hours. Every 6.000 hours or 12 month, inspect the discs for any fatigue crack and verify alignment.

### 5.1. Disassembly and inspection

Every 12.000 hours or every 24 month.

5.1.1. Remove the screws and nuts (4) each side.

5.1.2. Remove the spacer (3) and inspect the discs (2). In case of damage, the disc-pack (2) must be replaced.

DLC series

size	Distances				Alignement				T Nm	Socket	
	DLC		DLCC		X mm	Y - Z max. mm	H1 - H2 max. mm	$\frac{H1 + H2}{2}$ mm		size s mm	driver mm
	G standard mm	G (optional) mm	G mm	A mm							
28	100	(140)	56	116	0.1	0.1	0.1	$6.5 \pm 0.2$	12.5	10	1/4
38	100	(140)	46	116	0.1	0.1	0.11	$6.7 \pm 0.2$	12.5	10	1/4
45	100	(140)	26	116	0.1	0.1	0.12	$6.5 \pm 0.2$	12.5	10	1/4
55	100	(140)	22	122	0.1	0.2	0.16	$7.0 \pm 0.2$	30	13	3/8
65	100	(140, 180)	4	122	0.1	0.2	0.19	$9.0 \pm 0.2$	60	17	1/2
75	100	(140, 180)	4	132	0.1	0.2	0.22	$10.0 \pm 0.3$	100	19	1/2
85	140	(180, 250)	4	174	0.15	0.25	0.25	$13.0 \pm 0.4$	160	22	1/2

Tabulation 1

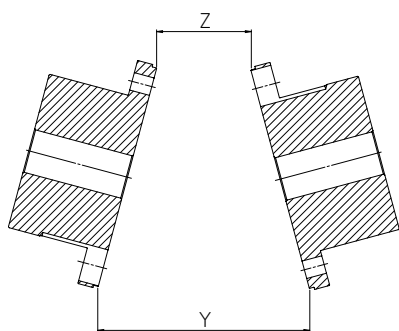

Figure 1.1

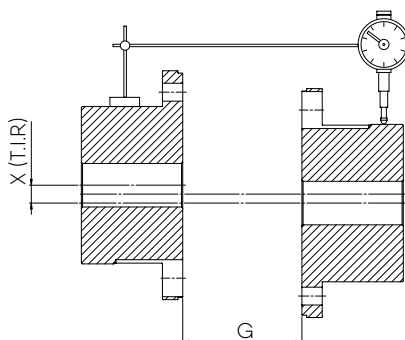

Figure 1.2

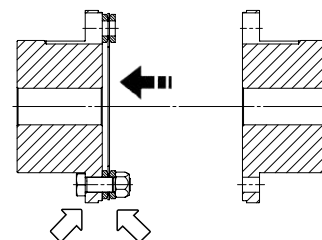

Figure 2

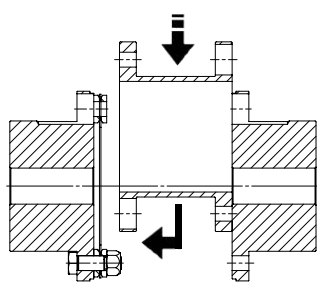

Figure 3

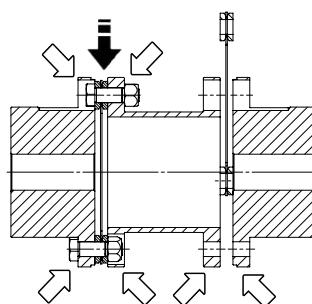

Figure 4

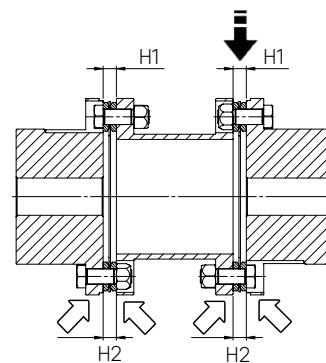

Figure 5

# Installation and maintenance DMU series

## 1) Introduction

Coupling must be selected properly according to selection chart B103a, B104a and B105a and corresponding charts (B1150a and B1160a).

These documents are available in coupling catalogue ESCO-DISC or on our web site « [www.escocoupling.com](http://www.escocoupling.com) ». Maximum misalignment figures at assembly are given in this document (see point 4: assembly). Max misalignment figures in operation (combination of radial, angular and axial) are given in ESCODISC catalogue. Max misalignment values may not be applied simultaneously as mentioned in selection chart B104a.

In case of any change or adaptation not performed by ESCO on the coupling, it is customer responsibility to size and manufacture it properly to guarantee safe torque transmission and absence of unbalance that could affect the life of the coupling and the connected machines.

It is customer responsibility to make sure that shaft and key material, size and tolerance suit the application. Maximum bore capacity is given in the catalogue.

If key assembly is not calculated and machined by ESCO, it is customer responsibility to make sure that hub length, bore size and machining tolerances will transmit the torque. If interference fit is not calculated and machined by ESCO, it is customer responsibility to make sure that interference and machining tolerances will transmit the torque and not exceed hub material permissible stress.

The hubs must be axially secured on the shaft by means of a setscrew, an end plate or a sufficient interference. In case of spacer not supplied by ESCO, it is customer responsibility to size and manufacture it properly to guarantee safe torque transmission and absence of unbalance that could affect the life of the Discs. It is customer responsibility to protect the coupling by p.ex. a coupling guard and to comply with the local safety rules regarding the protection of rotating parts.

## 2) Preparation

Ensure the conformity of the supplied equipment:

- Verify coupling size and conformity (see catalogue or web site).
- Identify any damaged and/or missing parts.
- Verify conformity of the coupling/machine interfaces.
- Coupling original protection allows for storage indoors dry 18 months, indoors humid 12 months, outdoors covered : 9 months and outdoors open 3 months. For longer periods, it is customer responsibility to protect the parts properly.
- Instructions are a part of the supply of the coupling. Be sure valid and complete assembly, operation and maintenance instructions are available. Make sure they are well understood. In case of doubt, refer to ESCO.

Assembly, disassembly and maintenance must be performed by qualified, trained and competent fitters.

Before starting with assembly, disassembly and maintenance, verify the availability of the tooling necessary

- To manipulate the parts
- To assemble the interfaces
- To align the coupling
- To tighten the screws and nuts

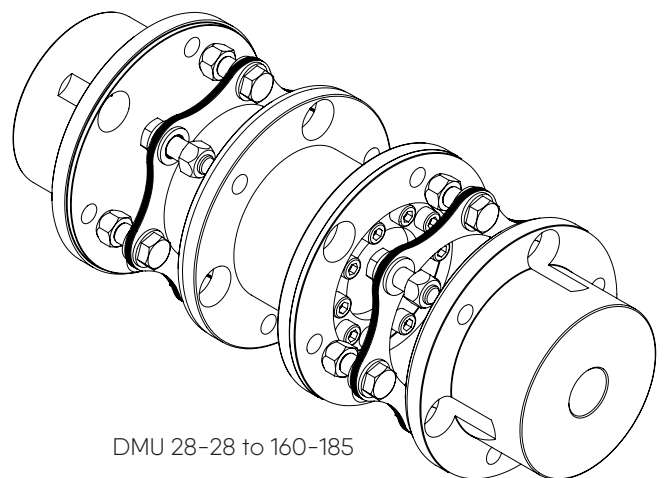

DMU 28-28 to 160-185

### 3) Warnings

Before removing the coupling guard and proceeding with any assembly, operation or maintenance operation of the coupling, make sure the complete system is completely shut down and definitively disengaged from any possible source of rotation, such as, for example :

- Electrical power supply
- Any loss of braking effect

Make sure everyone attending the equipment area will be properly informed (for example by means of warnings properly located) about the maintenance or assembly situation.

**In case of use in explosive atmosphere  $\text{Ex}$ , specific protective measures must be considered. They are described in an extra attachment (IM/A100a-Ex) to the actual instructions with, the couplings marked  $\text{Ex}$  .**

### 4) Assembly DMU couplings

#### 4.0. Warning

4.0.1. The hubs (1) and the spacer (4) are supplied unassembled. The disc-packs (3) are supplied packed with the screws (2) and nuts (5) under plastic film to ensure a perfect protection. They will only be unpacked during final mounting on the machine.

4.0.2. If coupling is supplied rough bored, bore and keyway must be machined in hubs (1). When machining the bore, surface marked (M) must be taken as the turning reference.

#### 4.1. DMU couplings (DMU 28-160)

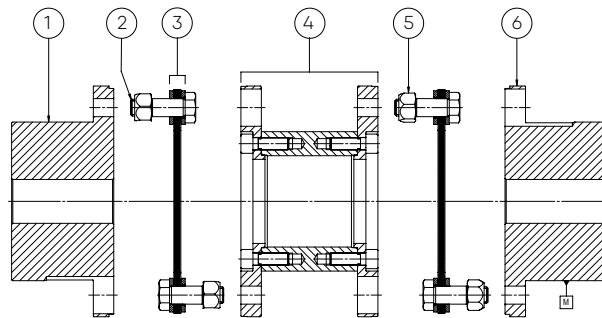

4.1.1. Ensure that parts are clean and mount the hubs (1) in the correct position on the shafts of the machines (the flange at the shaft end). Hub faces must be flush with shaft end. In case of doubt, please consult us. Introduce setscrew on key with Loctite and tighten properly. In case of interference fit, refer to ESCO for proper instructions.

4.1.2. Position the machines to be connected and check distance G between the hubs (fig. 1.1 & 1.2). See tabulation 1 or approved drawing for distance G following type of coupling. In case of doubt, please consult us.

4.1.3. Align the shafts using an indicator. The alignment precision (X, Y - Z) is given in the tabulation 1.

4.1.4. Ensure that the flanges of the hubs (1) and the spacer (4) are perfectly degreased. Unpack the discs and the screws. Mount the disc-pack (3) on one hub (1) with screws (2) and nuts (5) in the direction shown on the fig. 2. Tighten to torque T mentioned while holding the

screws still and turning the nuts. See tabulation 1 for tightening torque (T Nm) and socket size (s mm).

4.1.5. Install the spacer (4) between the hubs and connect it to the already assembled disc-pack (3) with screws (2) and nuts (5), in the direction shown on the fig. 3 (in case of long spacer, it is essential to support the spacer in position from the beginning to the end of the assembly). Tighten to torque T mentioned in the tabulation 1 while holding the screws still and turning the nuts.

4.1.6. Engage the second disc-pack (3) between the spacer (4) and the second hub (1) and assemble with screws (2) and nuts (5) as indicated in fig. 4.

4.1.7. Check once again the alignment by measuring the max. value H1 and the min. value H2 of the distance between the hub flange and the spacer flange (see fig. 5). See tabulation 1 for the permissible values.

4.2. DMU couplings (DMU 190-360)

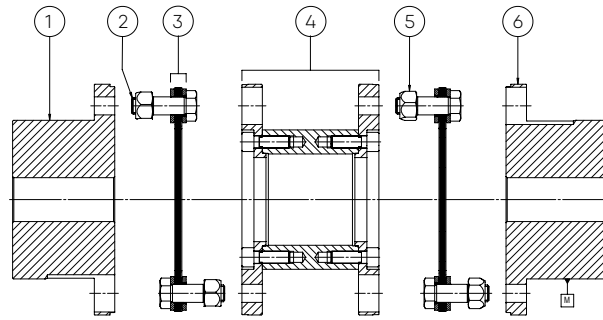

- 4.2.1. Ensure that parts are clean and mount the hubs (1) in the correct position on the shafts of the machines (the flange at the shaft end). Hub faces must be flush with shaft end. In case of doubt, please consult us. Introduce setscrew on key with Loctite and tighten properly. In case of interference fit, refer to ESCO for proper instructions.
- 4.2.2. Position the machines to be connected and check distance G between the hubs (fig. 1.1 & 1.2). See tabulation 1 or approved drawing for distance G following type of coupling. In case of doubt, please consult us.
- 4.2.3. Align the shafts using an indicator. The alignment precision (X, Y - Z) is given in the tabulation 1.
- 4.2.4. Ensure that the flanges of the hubs (1) and the spacer (4) are perfectly degreased. Unpack the link packs and the screws. Mount the link-pack (3) on one hub (1) with screws (2) and nuts (5) in the direction shown on the fig 2. Tighten to torque T mentioned while holding the screws still and turning the nuts. See tabulation 1 for tightening torque (T Nm) and socket size (s mm).
- 4.2.5. Install the spacer (4) between the hubs and connect it to the already assembled link-packs (3) with screws (2) and nuts (5), in the direction shown on the fig. 3 (in case of long spacer, it is essential to support the spacer in position from the beginning to the end of the assembly). Tighten to torque T mentioned in the tabulation 1 while holding the screws still and turning the nuts.

- 4.2.6. Engage the second link-packs (3) between the spacer (4) and the second hub (1) and assemble with screws (2) and nuts (5) as indicated in fig. 4.
- 4.2.7. Check once again the alignment by measuring the max. value H1 and the min. value H2 of the distance between the hub flange and the spacer flange (see fig. 5). See tabulation 1 for the permissible values.

5) Operation, inspection and maintenance

- 5.0. Operation and maintenance
  - 5.0.1 No maintenance is necessary. It is however recommended to verify the alignment (see point 4.1.7) and the tightening torque of the screws (2) and nuts (5) (see tabulation 1) after the first running hours. Every 6.000 hours or 12 month, inspect external discs of disc pack for any fatigue crack and verify alignment.
- 5.1. Disassembly and inspection
  - Every 12.000 hours or every 24 months.
  - 5.1.1. Remove the screws (2) and nuts (5) each side.
  - 5.1.2. Remove the spacer (4) and inspect the discs (3). In case of damage, the disc-pack (3) must be replaced.

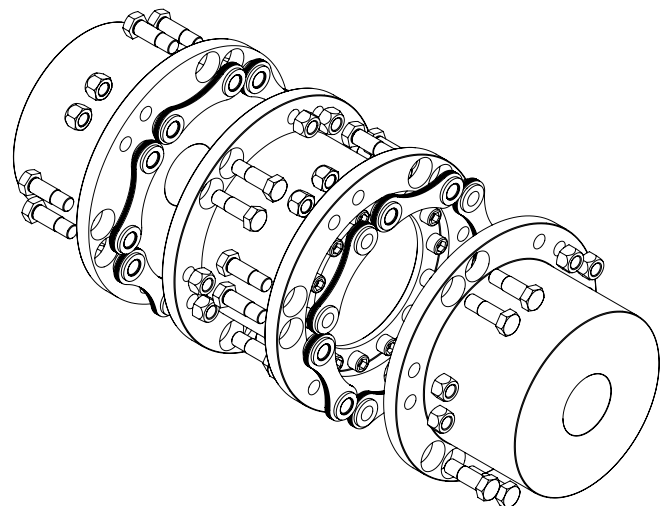

DMU 190-220 to 360-370

DMU series

size	Distances		Alignment				T Nm	Socket	
	DBSE		X mm	Y - Z max. mm	H1 - H2 max. mm	$\frac{H1 + H2}{2}$ mm		size mm	driver mm
	G standard mm								
38	100		0.12	0.24	0.24	$6.7 \pm 0.25$	14	10	1/4
45	100		0.08	0.16	0.17	$6.5 \pm 0.20$	14	10	1/4
55	100		0.08	0.16	0.19	$7.0 \pm 0.25$	34	13	3/8
65	100		0.08	0.16	0.21	$9.0 \pm 0.25$	67	17	1/2
75	140		0.11	0.22	0.26	$10.0 \pm 0.30$	114	19	1/2
85	140		0.11	0.22	0.28	$13.0 \pm 0.40$	180	22	1/2
95	140		0.11	0.22	0.3	$14.0 \pm 0.40$	277	24	1/2
110	180		0.14	0.28	0.36	$15.5 \pm 0.45$	380	27	3/4
125	180		0.14	0.28	0.38	$19.0 \pm 0.50$	540	30	3/4
140	250		0.2	0.4	0.46	$20.0 \pm 0.65$	725	32	3/4
160	250		0.2	0.4	0.5	$20.0 \pm 0.70$	920	36	3/4
190	250		0.13	0.26	0.35	$19.25 \pm 0.50$	540	30	3/4
220	280		0.15	0.29	0.4	$24.6 \pm 0.65$	920	36	3/4
250	300		0.11	0.22	0.34	$38.0 \pm 0.75$	1855	46	3/4
280	340		0.13	0.26	0.37	$41.0 \pm 0.80$	2 490	50	1
320	380		0.12	0.23	0.33	$44.9 \pm 0.90$	3 180	55	1
360	400		0.13	0.26	0.37	$347.9 \pm 0.90$	3 180	55	1

Tabulation 1

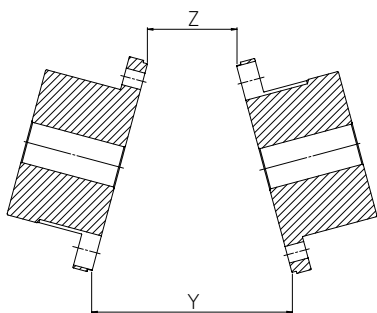

Figure 1.1

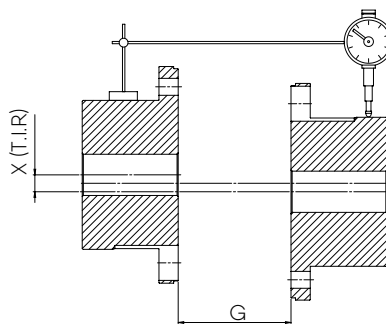

Figure 1.2

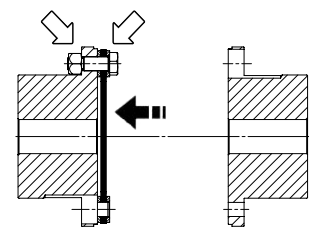

Figure 2

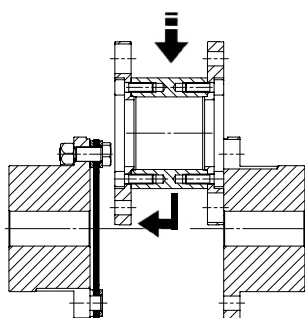

Figure 3

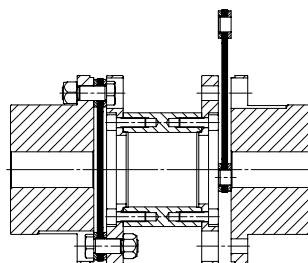

Figure 4

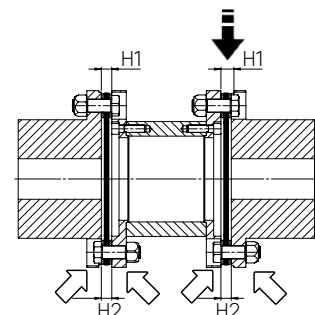

Figure 5

# Installation and maintenance

## DMUCC series

### 1) Introduction

Coupling must be selected properly according to selection chart B103a, B104a and B105a and corresponding charts (B1170a and B1180a).

These documents are available in coupling catalogue ESCO-DISC or on our web site « [www.escocoupling.com](http://www.escocoupling.com) ». Maximum misalignment figures at assembly are given in this document (see point 4: assembly). Max misalignment figures in operation (combination of radial, angular and axial) are given in ESCODISC catalogue. Max misalignment values may not be applied simultaneously as mentioned in selection chart B104a.

In case of any change or adaptation not performed by ESCO on the coupling, it is customer responsibility to size and manufacture it properly to guarantee safe torque transmission and absence of unbalance that could affect the life of the coupling and the connected machines.

It is customer responsibility to make sure that shaft and key material, size and tolerance suit the application. Maximum bore capacity is given in the catalogue.

If key assembly is not calculated and machined by ESCO, it is customer responsibility to make sure that hub length, bore size and machining tolerances will transmit the torque. If interference fit is not calculated and machined by ESCO, it is customer responsibility to make sure that interference and machining tolerances will transmit the torque and not exceed hub material permissible stress.

The hubs must be axially secured on the shaft by means of a setscrew, an end plate or a sufficient interference. In case of spacer not supplied by ESCO, it is customer responsibility to size and manufacture it properly to guarantee safe torque transmission and absence of unbalance that could affect the life of the Discs. It is customer responsibility to protect the coupling by p.ex. a coupling guard and to comply with the local safety rules regarding the protection of rotating parts.

### 2) Preparation

Ensure the conformity of the supplied equipment:

- Verify coupling size and conformity (see catalogue or web site).
- Identify any damaged and/or missing parts.
- Verify conformity of the coupling/machine interfaces.
- Coupling original protection allows for storage indoors dry 18 months, indoors humid 12 months, outdoors covered : 9 months and outdoors open 3 months. For longer periods, it is customer responsibility to protect the parts properly.
- Instructions are a part of the supply of the coupling. Be sure valid and complete assembly, operation and maintenance instructions are available. Make sure they are well understood. In case of doubt, refer to ESCO.

Assembly, disassembly and maintenance must be performed by qualified, trained and competent fitters.

Before starting with assembly, disassembly and maintenance, verify the availability of the tooling necessary

- To manipulate the parts
- To assemble the interfaces
- To align the coupling
- To tighten the screws and nuts

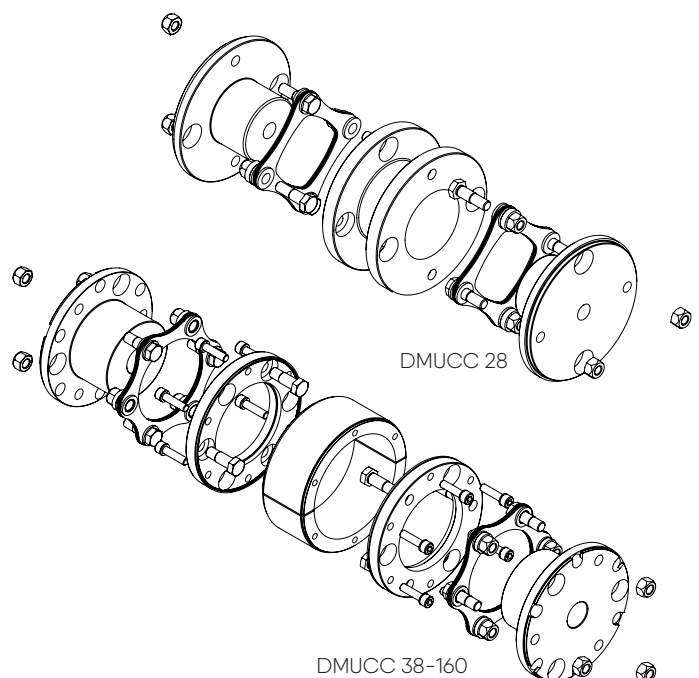

### 3) Warnings

Before removing the coupling guard and proceeding with any assembly, operation or maintenance operation of the coupling, make sure the complete system is completely shut down and definitively disengaged from any possible source of rotation, such as, for example :

- Electrical power supply
- Any loss of braking effect

Make sure everyone attending the equipment area will be properly informed (for example by means of warnings properly located) about the maintenance or assembly situation.

**In case of use in explosive atmosphere  $\text{Ex}$ , specific protective measures must be considered. They are described in an extra attachment (IM/A100a-Ex) to the actual instructions with, the couplings marked  $\text{Ex}$ .**

### 4) Assembly DMUCC couplings

#### 4.0. Warning

4.0.1. The hub sub-assembly, including the hub (1), the disc-pack (2), the rings (3), the screws (C), the nuts (B) and the sandwich flange (5) are factory pre-assembled and may not be disassembled unless in case of disc-pack change (see fig. 1 and point 5.2.2).

4.0.2. The hub sub-assembly indicated in 4.0.1. is supplied compressed and rigidified with shipping screws (10), rings (9) and inserts (8). These shipping screws must be removed at assembly and before starting the machines (see point 4.1.8.)

4.0.3. If hubs are supplied rough bored, bore and keyway must be machined in the hubs (1):

- Without dismantling the sub-assembly (see point 0.1.)
- Without dismantling the shipping screws (10)
- Taking the surface marked (M) as the turning reference.

#### 4.1. DMUCC couplings (DMUCC 28)

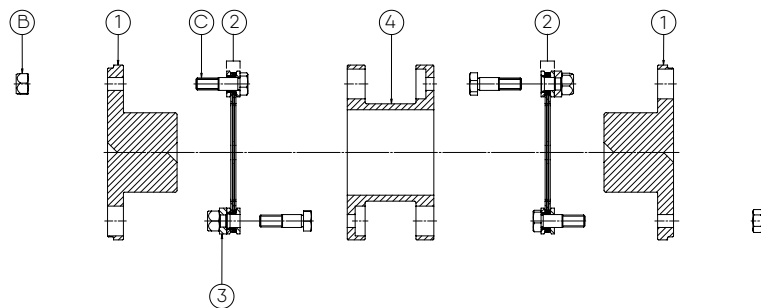

4.1.1. Ensure that parts are clean and mount the hubs (1) in the correct position on the shafts of the machines the flange at the machine side. Hub faces must be flush with shaft end. In case of doubt, please consult us. Introduce setscrew on key with Loctite and tighten properly. In case of interference fit, refer to ESCO for proper instructions.

4.1.2. Position the machines to be connected. The spacer (4) and the discs (2) must be placed on the hubs (1) during the installation, see also point 4.1.4 and check distance G between the hubs (check also distance A). See tabulation 1 or approved drawing for distance G following type of coupling. In case of doubt, please consult us.

4.1.3. Align the shafts using an indicator. The alignment precision (X, Y - Z) is given in the tabulation 1.

4.1.4. Ensure that the flanges of the hubs (1) and the spacer (4) are perfectly degreased. Unpack the discs and the screws. Mount the disc (2) on one hub (1) with screws (C) and nuts (B). Tighten to torque T while holding the

screws still and turning the nuts. See tabulation 1 for tightening torque (T Nm) and socket size (s mm).

4.1.5. Engage the second disc (2) on the second hub (1) and assemble with screws (C) and nuts (B) as indicated above.

4.1.6. Install the spacer (4) between the hubs and connect it to the already assembled disc (2) with screws (C) and nuts (B) along with ring (3) (in case of long spacer, it is essential to support the spacer in position from the beginning to the end of the assembly). Tighten to torque T mentioned while holding the screws still and turning the nuts. See tabulation 1 for tightening torque (T Nm) and socket size (s mm).

4.1.7. Check once again the alignment by measuring the max. value H1 and the min. value H2 of the distance between the hub flange and the spacer flange (see fig. 5). See tabulation 1 for the permissible values.

4.2. DMUCC couplings (DMUCC 38-360)

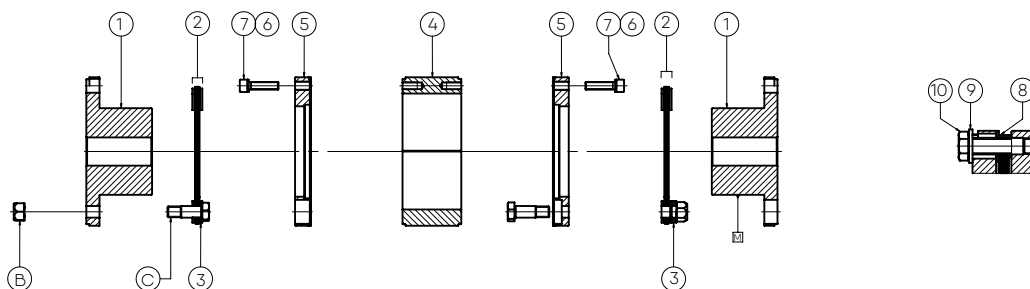

- 4.2.1. Dismount spacer in two parts (4) by removing screws (7) and washers (6) on both sides.
- 4.2.2. Clean all the parts thoroughly.
- 4.2.3. Mount the hub sub-assemblies on their respective shafts. The hub faces must be flush with the shaft ends. In case of doubt, please consult us.
- 4.2.4. Position the units to be connected and check the distance G between the hubs (for spacer (4) in one piece, check also distance A). See tabulation 1 or (in case of a special execution) an approved drawing for the distance G corresponding to the coupling size. In case of doubt, please consult us.
- 4.2.5. Align the two shafts (see fig 2 and 3). Alignment precision (X and Y - Z) is given in tabulation 1.
- 4.2.6. Ensure that spacer (4) ends, and sandwich flanges (5) faces are perfectly degreased. Introduce spacer in two parts (4) between the two sub-assemblies. Engage screws (7) with their washers (6) in both ends of both spacer parts (4). Do not tighten it completely at this stage. this operation is to hold the spacer in place. (see fig. 3)
- 4.2.7. Remove the shipping screws (10) with their washers (9) and their inserts (8) at each end (see figure 4) and engage the remaining screws (7) with their rings (6) in each spacer end (see fig 4). Tighten screws uniformly using the tightening torque (T1 in Nm) and key size (s mm) indicated in tabulation 1.
- 4.2.8. Check alignment and axial distance by measuring the max. value H1 and the min. value H2 of the distance between the hub (1) flange and the sandwich flange (5) (see fig. 5). See tabulation 1 for permissible values.

5) Operation, inspection and maintenance

- 5.0. Operation and maintenance
  - 5.0.1 No maintenance is necessary. However, it is recommended to verify alignment and tightening torque T1 of the screws (7) after the first running hours. Every 6.000 hours or 12 months, inspect external discs of disc pack for any fatigue crack and verify alignment.
- 5.1. Disassembly and inspection
  - Every 12.000 hours or every 24 month.
  - 5.1.1. Remove the 6 screws (7) with their rings (6) on both sides. Introduce the shipping screws (10) with their rings (9) and their inserts (8) at each end and tighten the screws (10) to compress the two disc-packs. Note that the minimum distance H0 in stationary condition between the hub (1) flange and the sandwich flange (5) should never be less than the H0 value given in the tabulation 1.
  - 5.1.2. Remove the spacer (4) in two parts and inspect the discs (2). In case of breakage, the disc-packs (2) must be replaced respecting assembly indicated in the figure 1. The tightening torque T2 (in Nm) and socket size (s mm) of the screws (C) and the nuts (B) is given tabulation 1.

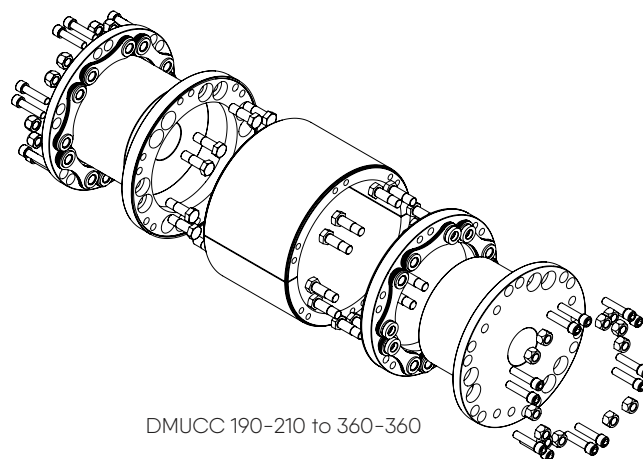

DMUCC 190-210 to 360-360

DMUCC series

size	Distances		Alignement					Spacer		Disc Pack		
	DBSE		X mm	Y - Z max. mm	H1 - H2 max. mm	H1 + H2 2 mm	H <sub>0</sub> mm	T1 Nm	S mm	T2 Nm	size mm	driver mm
	G standard mm	A standard mm										
28	3					6.5 ± 0.20	5.5	-	-			
38	3	73	0.12	0.24	0.24	6.5 ± 0.20	5.5	8.1	4	14	10	0.25
45	3	93	0.1	0.1	0.12	6.5 ± 0.20	5.5	8.1	4	14	10	1/4
55	3	103	0.1	0.2	0.16	7.0 ± 0.20	5.7	13.2	5	34	13	3/8
65	4	122	0.1	0.2	0.19	9.0 ± 0.20	7.6	32	6	67	17	1/2
75	4	132	0.1	0.2	0.22	10.0 ± 0.30	8.3	55	8	114	19	1/2
85	4	174	0.2	0.25	0.25	13.0 ± 0.40	11	63	8	180	22	1/2
95	4	194	0.2	0.25	0.29	14.0 ± 0.40	12	100	10	277	24	1/2
110	6	226	0.2	0.3	0.32	15.5 ± 0.50	13.4	108	10	380	27	3/4
125	6	256	0.25	0.3	0.36	19.0 ± 0.50	17.0	180	12	540	30	3/4
140	6	286	0.3	0.4	0.4	20.0 ± 0.50	17.5	230	14	725	32	3/4
160	8	328	0.35	0.4	0.45	20.0 ± 0.60	17.5	280	14	920	36	3/4
190	6	386	0.35	0.4	0.46	22.0 ± 0.10	17.4	390	18	540	30	3/4
220	8	448	0.4	0.5	0.54	24.6 ± 0.10	22.1	390	18	920	36	3/4
250	10	510	0.35	0.4	0.47	38.0 ± 0.40	35.2	390	18	1855	46	3/4
280	10	570	0.35	0.5	0.51	41.0 ± 0.40	38.0	552	20	2 490	50	1
320	12	652	0.35	0.4	0.45	44.9 ± 0.40	41.5	954	24	3 180	55	1
360	12	732	0.4	0.5	0.53	34.0 ± 0.40	45.6	954	24	3 180	55	1

Tabulation 1

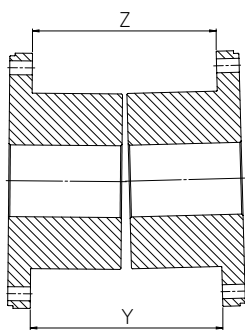

Figure 1.1

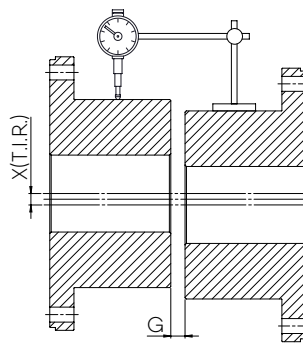

Figure 1.2

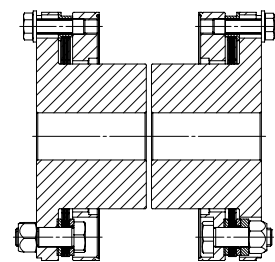

Figure 2

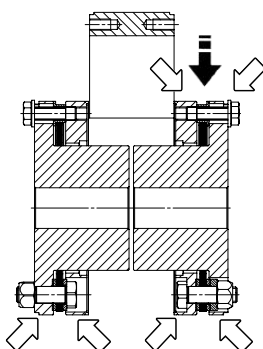

Figure 3

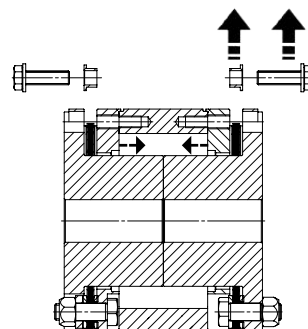

Figure 4

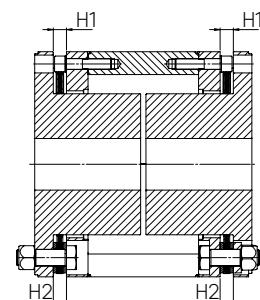
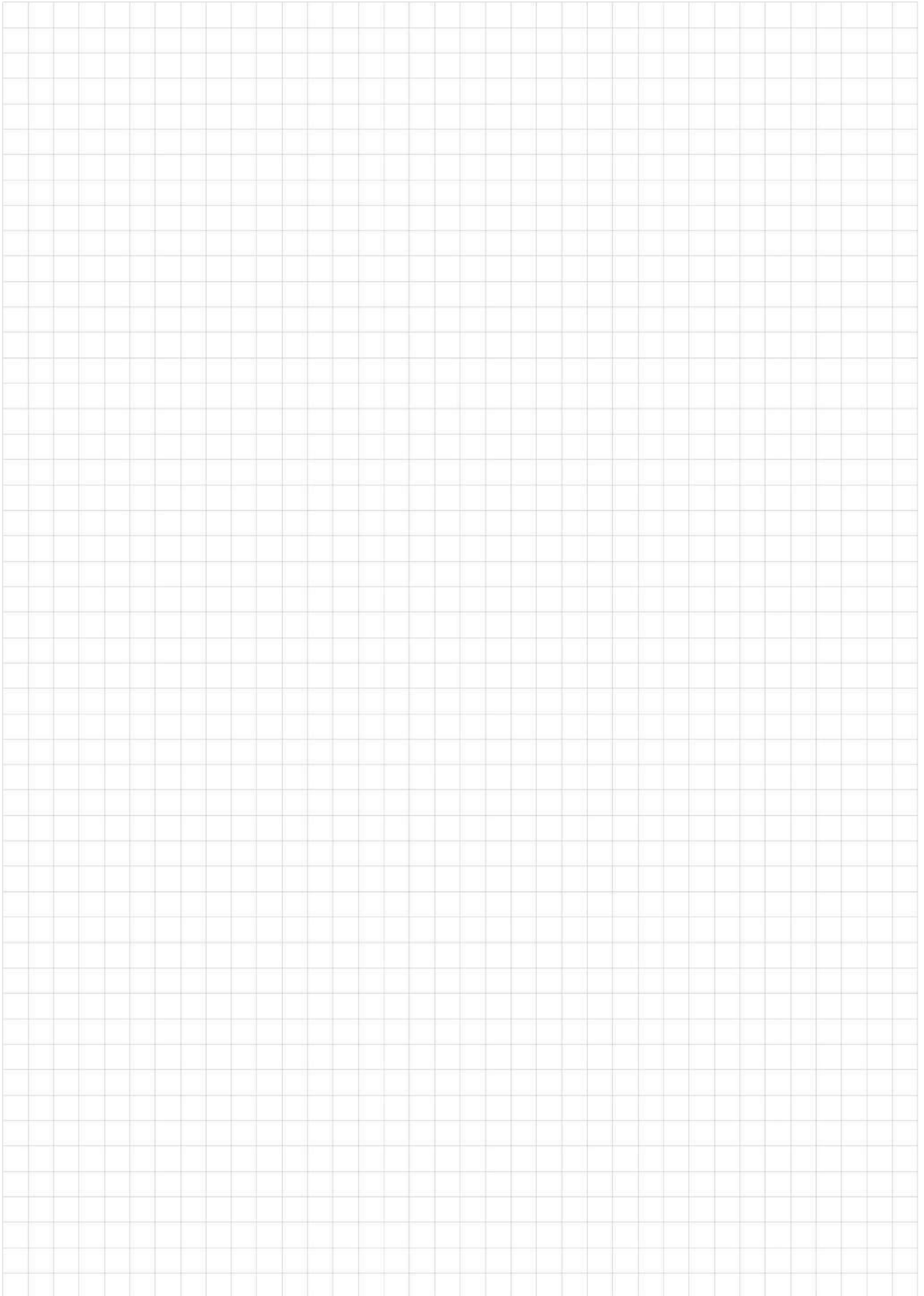

Figure 5

Notes:



# Installation and maintenance

## DPU series

### 1) Introduction

Coupling must be selected properly according to selection chart B103a, B104a and B105a and corresponding charts (B1210a, B1211a and B1220a).

These documents are available in coupling catalogue ESCO-DISC or on our web site « [www.escocoupling.com](http://www.escocoupling.com) ». Maximum misalignment figures at assembly are given in this document (see point 4: assembly). Max misalignment figures in operation (combination of radial, angular and axial) are given in ESCODISC catalogue. Max misalignment values may not be applied simultaneously as mentioned in selection chart B104a.

In case of any change or adaptation not performed by ESCO on the coupling, it is customer responsibility to size and manufacture it properly to guarantee safe torque transmission and absence of unbalance that could affect the life of the coupling and the connected machines.

It is customer responsibility to make sure that shaft and key material, size and tolerance suit the application. Maximum bore capacity is given in the catalogue.

If key assembly is not calculated and machined by ESCO, it is customer responsibility to make sure that hub length, bore size and machining tolerances will transmit the torque.

If interference fit is not calculated and machined by ESCO, it is customer responsibility to make sure that interference and machining tolerances will transmit the torque and not exceed hub material permissible stress.

The hubs must be axially secured on the shaft by means of a setscrew, an end plate or a sufficient interference. In case of spacer not supplied by ESCO, it is customer responsibility to size and manufacture it properly to guarantee safe torque transmission and absence of unbalance that could affect the life of the Discs. It is customer responsibility to protect the coupling by p.ex. a coupling guard and to comply with the local safety rules regarding the protection of rotating parts.

### 2) Preparation

Ensure the conformity of the supplied equipment:

- Verify coupling size and conformity (see catalogue or web site).
- Identify any damaged and/or missing parts.
- Verify conformity of the coupling/machine interfaces.
- Coupling original protection allows for storage indoors dry 18 months, indoors humid 12 months, outdoors covered : 9 months and outdoors open 3 months. For longer periods, it is customer responsibility to protect the parts properly.
- Instructions are a part of the supply of the coupling. Be sure valid and complete assembly, operation and maintenance instructions are available. Make sure they are well understood. In case of doubt, refer to ESCO.

Assembly, disassembly and maintenance must be performed by qualified, trained and competent fitters.

Before starting with assembly, disassembly and maintenance, verify the availability of the tooling necessary

- To manipulate the parts
- To assemble the interfaces
- To align the coupling
- To tighten the screws and nuts

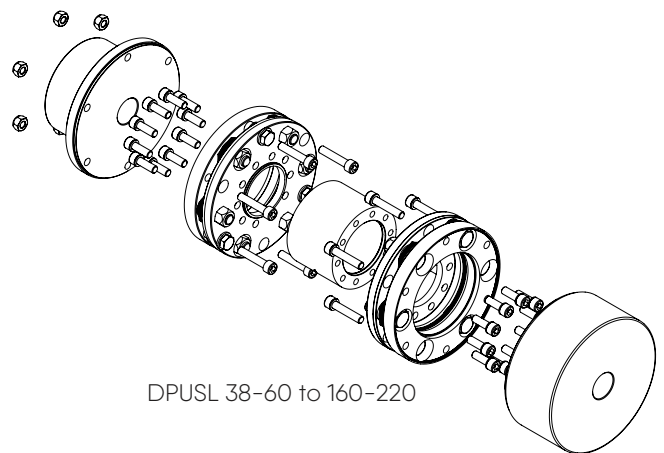

## 3) Warnings

Before removing the coupling guard and proceeding with any assembly, operation or maintenance operation of the coupling, make sure the complete system is completely shut down and definitively disengaged from any possible source of rotation, such as, for example :

- Electrical power supply
- Any loss of braking effect

Make sure everyone attending the equipment area will be properly informed (for example by means of warnings properly located) about the maintenance or assembly situation.

**In case of use in explosive atmosphere  $\text{Ex}$ , specific protective measures must be considered. They are described in an extra attachment (IM/A100a-Ex) to the actual instructions with, the couplings marked  $\text{Ex}$ .**

## 4) Assembly DPU couplings

### 4.0. Warning

- 4.0.1. The pack sub-assembly (1) including flange DP (1.1) discs (1.2), sandwich flange (1.3) and bolts and nuts (1.4) has to be considered as one single component. Bolts have been factory tightened for optimal torque transmission and infinite life. It may not be disassembled. Any external intervention to this sub-assembly (torquing bolts and nuts, separating components) will automatically cancel suppliers warranty, customer being fully responsible of any operation risk and damage.
- 4.0.2. The pack sub-assembly (1) is supplied compressed and fixed by shipping screws (15). This arrangement

protects the flexible discs during storage and shipment and makes assembly easier. These shipping screws (15) must be removed at assembly and before starting the machines (see point 4.1.5).

- 4.0.3. If coupling is supplied rough bored, bore and keyway must be machined in hubs (8) and (9). When machining the bore, surface marked (M) must be taken as the turning reference.
- 4.0.4. It is customer's responsibility to protect the coupling and to conform his equipment do local safety legislation.

### 4.1. DPU 38-360 couplings

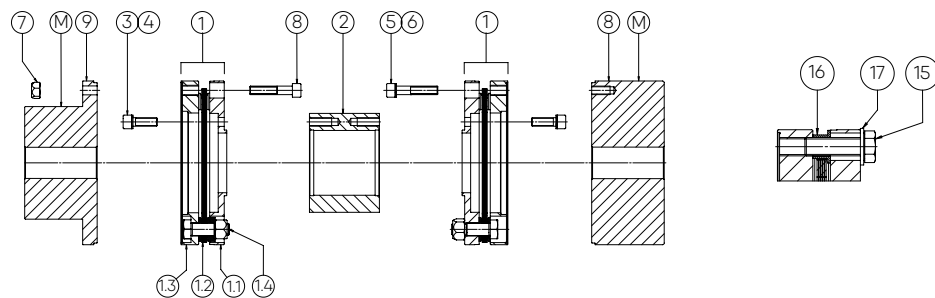

- 4.1.1. Install hubs (8) and (9) on their respective shafts in their proper position (see fig. 6). Hub faces must be flush with shaft end. In case of doubt, please consult us. Introduce setscrew on key with Loctite and tighten properly. In case of interference fit, refer to ESCO for proper instructions.
- 4.1.2. Position units to be connected and check distance G between the hubs. See tabulation 1 or approved drawing for correct distance G, according to coupling type. In case of doubt, please consult us.
- 4.1.3. Align the two shafts using an indicator. Alignment precision (X and Y - Z) is given in alignment tabulation 1.
- 4.1.4. Ensure that both spacer ends (2) and DP flange (1.1) are perfectly degreased. Mount (see fig. 2) sub-assemblies (1) on spacer (2) with screws (3) and washers (4). Tighten screws (3) uniformly (tightening torque T3). See tabulation 1 for correct tightening torque (Spacer T3 Nm) and key size (s mm).
- 4.1.5. Ensure that both hub faces (8) and (9) and sandwich flange (1.3) are perfectly degreased. Introduce floating assembly between the two hubs (fig. 3). Remove the

shipping screws (15) with rings (17) and shipping inserts (16) at each end (fig. 4). The floating assembly must be maintained in position by the two hubs (8) and (9). If not, the distance between the hubs and (or) the alignment are wrong and must be corrected (see points 1.3 and 1.4).

- 4.1.6. Engage the screws (5) and washers (6) or/and the screws and nuts (7) (following case) in each hub (fig. 5). Tighten the screws (5) or (7) uniformly (tightening torque T5). See tabulation 1 for correct tightening torque T5 Nm and Allen key size (s mm).
- 4.1.6a ASSEMBLY DPULE (limited end float)  
During assembly of each screws (5) and washers (6) or/and each screw and nuts (7) (following case) on each side, slip one « axial limiter short » between the DP flange (1.1) and the sandwich flange (1.3) of the pack sub-assembly (1) and one « axial limiter long » in each hole of the DP flange (1.1) (fig. 7). Tighten the screws (5) or (7) uniformly (tightening torque T5 Nm and Allen key size (s mm).

4.1.7. Check once again alignment and axial distance by measuring max. value H1 and min. value H2 of the distance between flange DP (1.1) and sandwich flange 1.3) (see figure). See alignment tabulation 1 for permissible values.

4.2. DPU 28 coupling

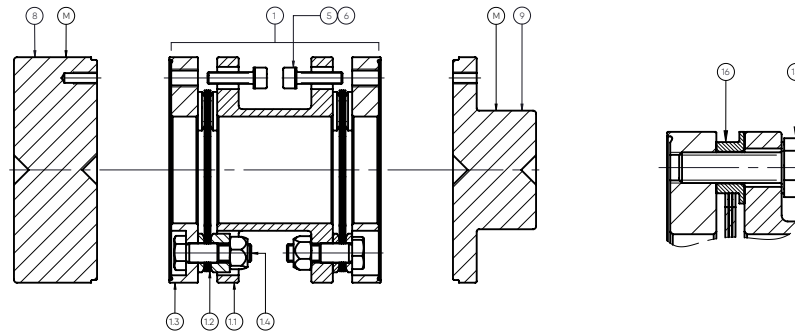

- 4.2.1. Install hubs (8) and (9) on their respective shafts in their proper position. Hub faces must be flush with shaft end. In case of doubt, please consult us. Introduce setscrew on key with Loctite and tighten properly. In case of interference fit, refer to ESCO for proper instructions.
- 4.2.2. Position units to be connected and check distance G between the hubs. See tabulation 1 or approved drawing for correct distance G, according to coupling type. In case of doubt, please consult us.
- 4.2.3. Align the two shafts using an indicator. Alignment precision (X and Y - Z) is given in alignment tabulation 1.
- 4.2.4. Ensure that both spacer ends (2) and DP flange (1.1) are perfectly degreased.

- 4.2.5. Ensure that both hub faces (8) and (9) and sandwich flange (1.3) are perfectly degreased. Introduce floating assembly between the two hubs (fig. 3). Remove the shipping screws (15) with rings (17) and shipping inserts (16) at each end (fig. 4). The floating assembly must be maintained in position by the two hubs (8) and (9). If not, the distance between the hubs and (or) the alignment are wrong and must be corrected (see points 1.3 and 1.4).
- 4.2.6. Engage the screws (5) and washers (6) or/and the screws and nuts (7) (following case) in each hub. Tighten the screws (5) or (7) uniformly (tightening torque T5). See tabulation 1 for correct tightening torque T5 Nm and Allen key size (s mm).

5) Operation, inspection and maintenance

5.0. Operation and maintenance

5.0.1 No maintenance is necessary; however, it is recommended to verify alignment (see point 4.1.7) and tightening torque of the screws (5) (see point 4.1.6) after the first running hours. Every 6.000 hours or 12 month, inspect external discs of disc pack for any fatigue crack and verify alignment.

- 5.1. Disassembly and inspection  
Every 12.000 hours or every 24 month.
- 5.1.1. Remove the 6 screws (5) or (7) (according to the case) each side. Introduce the shipping screws (15) and shipping inserts (16) and tighten the screws (15) to compress pack sub-assembly (1). Note that the minimum distance H0 in stationary condition between flange DP (1.1) and sandwich flange (1.3) should never be less than H0 given in tabulation 1.
- 5.1.2. Remove floating assembly (2) and inspects discs (1.2) without dismounting hub sub-assembly (1) (see point 4.0.1). In case of damage, complete sub-assembly (1) must be replaced.

DPU series

size	Distances		Alignment				Spacer		Hubs		
	DBSE	G Standard mm	X mm	Y - Z max. mm	H1 - H2 max. mm	$\frac{H1 + H2}{2}$ mm	H0 mm	T3 Nm	s mm	T5 mm	s mm
	G										
38	100		0.1	0.1	0.11	$7.1 \pm 0.20$	5.5	8.1	4	8.1	4
45	100		0.1	0.1	0.12	$6.5 \pm 0.20$	5.5	13.2	5	8.1	4
55	100		0.1	0.15	0.16	$7.0 \pm 0.20$	5.7	13.2	5	13.2	5
65	140		0.15	0.2	0.19	$9.0 \pm 0.20$	7.6	32	6	32	6
75	140		0.15	0.2	0.22	$10.0 \pm 0.30$	8.3	32	6	55	8
85	180		0.15	0.25	0.25	$13.0 \pm 0.40$	11	63	8	63	8
95	180		0.1	0.2	0.2	$14.0 \pm 0.20$	12	63	8	100	10
110	250		0.15	0.2	0.2	$15.5 \pm 0.30$	13.4	108	10	108	10
125	250		0.15	0.25	0.25	$19.0 \pm 0.30$	17	108	10	180	12
140	250		0.15	0.25	0.25	$20.0 \pm 0.30$	17.5	108	10	230	14
160	250		0.15	0.3	0.3	$20.0 \pm 0.40$	17.5	180	12	280	14
190	250		0.2	0.3	0.28	$22 \pm 0.2$	20.1	283	16	283	16
220	280		0.25	0.3	0.33	$24.6 \pm 0.3$	22.1	390	18	390	18
250	300		0.2	0.6	0.62	$38 \pm 0.4$	35.2	390	18	390	18
280	340		0.2	0.7	0.68	$41 \pm 0.4$	38.0	552	20	552	20
320	380		0.2	0.5	0.45	$44.9 \pm 0.4$	41.5	954	24	954	24
360	400		0.2	0.5	0.53	$47.8 \pm 0.3$	45.6	954	24	954	24

Tabulation 1

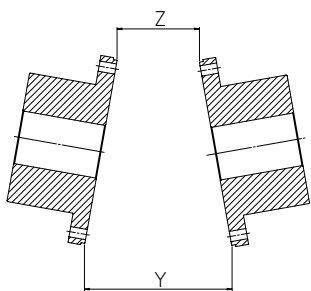

Figure 1.1

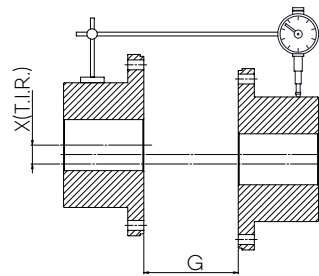

Figure 1.2

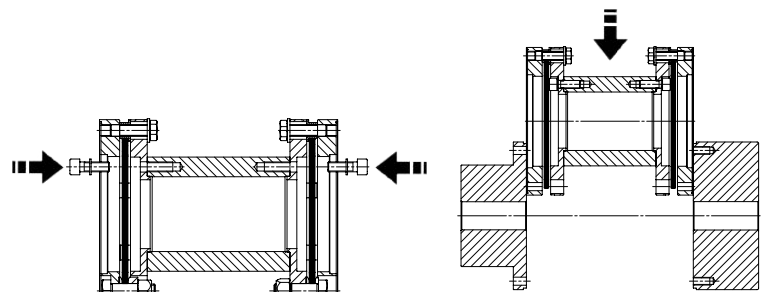

Figure 2

Figure 3

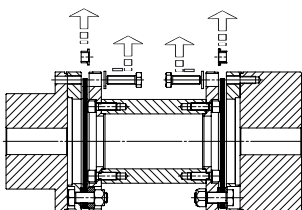

Figure 4

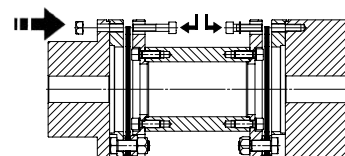

Figure 5

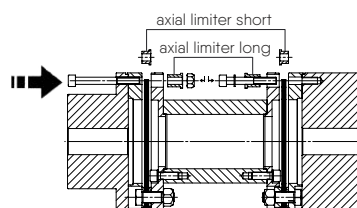

Figure 6

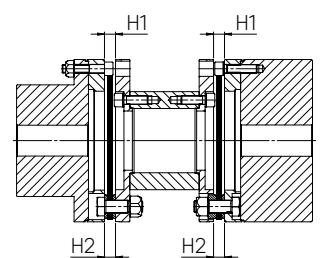

Figure 7

# ATEX

## Specific protective measures taken for ESCODISC couplings in case of use in explosive atmospheres.

### 1) Introduction

General assembly and maintenance instructions (called IM in this attachment) are established for standard ESCODISC couplings according to the following list:

- IM/A100-2 for ESCODISC DLC couplings
- IM/A100-3 for ESCODISC DMU couplings
- IM/A100-4 for ESCODISC DPU couplings
- IM/A100-5 for ESCODISC DMUCC couplings

**In case of use in potentially explosive atmospheres, further to the general assembly and maintenance instructions (IM/...), the specific measures described in this attachment must be taken.**

### 2) Coupling Selection

The coupling must be selected according to the general assembly and maintenance instruction IM/...

In explosive atmosphere  $\text{Ex}$ , the following specific rules must apply:

- A Service Factor of 1.5 must be applied on the max torque values for nominal torque ( $T_n$ ) and peak torque ( $T_p$ ) given in the charts in catalogue (see selectionchart A104 and A105)

### 3) Use of the coupling

The coupling is dedicated to be used in potentially explosive atmospheres according to European Directive 2014/34/EU (ATEX 100A).

Coupling is classified in equipment group II, equipment category 2 and 3, intended to be used in areas in which explosive atmospheres caused by gases, vapours, mists of air/dust mixtures are likely to occur.

In function of the ambient temperature in the coupling proximity (85, 55, 45°C), the temperature classes have been defined (T4, T5, T6).

This is based on a temperature increase of the machine shafts (in regard of the ambient temperature) that will not exceed 50°C in operation.

The coupling is marked as follows:

**CE  $\text{Ex}$  II 2 G T4/T5/T6 D 120°C**  
**-20°C ≤ Ta ≤ 85°C/55°C/45°C**

This marking covers the T3 temperature category.

This marking covers all gas categories: G IIA, G IIB and G IIC.

### 4) Warnings

The warnings mentioned in the general assembly and maintenance instructions IM/... must apply in any case.

In explosive atmospheres  $\text{Ex}$ , the following specific warnings must apply:

- Complete machining of the coupling parts (bores, keyways, spacers, floating shafts etc...) must be performed by ESCO Couplings SRL. No modification shall be made on the supplied and marked product without the agreement of ESCO Couplings SRL.
- In case of supply by ESCO Couplings SRL of couplings with a rough bore or a solid bore, the sole allowed operation that may be performed by customer is the boring and keywaying of the coupling hubs.

When machining the bore and the keyway, the following instructions must be followed:

- This job must be performed by an authorised and adequately trained and informed operator.
- The bore and keyway tolerances must be selected to ensure the proper fit between shaft and bore. In case of loose fit, a set screw must be foreseen to locate the hub axially.
- The max. bore may not exceed the value stated in the catalogue. The tabulated values in the catalogue are based on key dimensions according to ISO R773.
- The reference used to center the piece when boring, is the one referenced D in the figures of the catalogue.
- Before proceeding with any assembly, operation or maintenance operation on the coupling, make sure that the necessary measures have been taken to ensure safety, such as but not limited to:
  - Proper ventilation if the area
  - Proper lightening and electrical tools.
- If hub must be heated for assembly on the shaft, make sure heating source and surface temperature will not affect the safety of the working area.
- It is recommended to have a strong coupling guard, preferably in stainless steel with openings (if any) smaller than the smallest centrifugable part (nut is 10 mm dia). The coupling guard is intended to protect the environment from the centrifugation of any rotating part and the rotating coupling from any falling part. To limit ventilation effects, distance between cover and coupling outside surface should be at least 10 mm.

## 5) Assembly

The general assembly and maintenance instructions IM/... must apply in any case.

In explosive atmospheres  $\text{Ex}$ , the following specific instructions must apply:

- Alignment of the machine in cold condition must taken into account the possible heat expansion to make sure that in continuous running conditions, max misalignment calculated on the base of selection chart A104 will not exceed 80% of the max allowed value:  

$$D_a/\Delta k_a + a/\Delta k_w + d_r/\Delta k_r \leq 0.80$$

## 6) Operation

The general assembly and maintenance instructions IM/... must apply in any case.

In explosive atmospheres  $\text{Ex}$ , the following specific instructions must apply:

- Before Start-up
  - Make sure coupling is perfectly clean and properly aligned.
  - Make sure, screws, nuts and plugs are properly tightened.
  - Coupling guard must be properly installed and fixed.
  - Monitoring system, if any, must be tested to verify its effectiveness.
- During start up
  - Check for any abnormal noise and/or vibration. If any, immediate stop is mandatory and appropriate actions must be taken.

- Checking intervals during operation
  - After the first 3 000 hours or 6 months: check
    - Inspect external disc for any fatigue crack.
    - Verify alignment
- Continuous checking
  - Immediately stop the machine if noise, vibrations or other abnormal phenomena are detected during operation.
  - Further more, if direct check is not possible for access or safety reasons, proper monitoring system has to be installed to follow up couplings behaviour.

## 7) Maintenance

The general assembly and maintenance instructions IM/... must apply in any case.

In explosive atmospheres  $\text{Ex}$ , the following specific instructions must apply:

- Every 8 000 hours or 18 month:
  - Dismount the coupling and inspect
  - Proceed as indicated in point 4.



# ESCO worldwide

## ESCO Couplings SRL

Avenue Ernest Solvay, 48

B - 1480 Saintes

Belgium

Tel + 32 (0) 2 715 65 60

Fax + 32 (0) 2 720 83 62

e-mail: [info@esco-couplings.be](mailto:info@esco-couplings.be)

website: [www.escogroup.com](http://www.escogroup.com)



## ESCO Couplings & Transmissions Pvt. Ltd.

Plot No. 69-D

Bengaluru Aerospace Park

Unachuru Village Jala Hobli

Bengaluru

India

Tel +91 80 7100 1800

e-mail: [info@esco-couplings.co.in](mailto:info@esco-couplings.co.in)

website: [www.escogroup.com](http://www.escogroup.com)

## Local Contact

Authorised distributor



TYMA CZ, s.r.o.

Na Pískách 731/12

CZ - 40004 Trmice, Czech Republic

Phone: +420 475 655 010

Email: [info@tyma.cz](mailto:info@tyma.cz)

[www.tyma.cz](http://www.tyma.cz)

Version 01-2025