

# ESCOGEAR F series



**EXPERTISE DRIVEN | CUSTOMER FOCUSED | SUSTAINABLE THINKERS**



## INDEX

We connect the world .....	4	FSV/FSUSV 280 – 450N.....	33
Global footprint.....	6	FSVA/FSUSVA 45 – 275.....	34
The right solution for your application.....	8	FSVA/FSUSVA 280 – 450N .....	35
Why ESCOGEAR F?.....	10	FST-SHSD/FSU-SHSD 45 – 275.....	36
Availabilities.....	12	FST-SHLD/FSU-SHLD 45 – 275 .....	37
How to select the right coupling size.....	14	FSH/FSUSH 45 – 275.....	38
Notes .....	17	FDSH/FSUDSH 45 – 275 .....	39
FST/FSUST 45 – 275.....	18	FLE/FSULE 45 – 275.....	40
FST/FSUST 280 – 1130.....	19	FSELE/FSUSELE 45 – 275.....	41
FMM/FSUMM 45 – 275 .....	20	FBD/FSUBD 45 – 275.....	42
FMM/FSUMM 280 – 450N .....	21	FBDS/FSUBDS 45 – 275.....	43
FDMM/FSUDMM 45 – 275 .....	22	FBP/FSUBP 45 – 275 .....	44
FDMM/FSUDMM 280 – 450N .....	23	FWD 150 – 420 .....	45
FSE/FSUSE 45 – 275 .....	24	FSP/FSUSP 45 – 275.....	46
FSE/FSUSE 280 – 450N .....	25	FET/FSUET 45 – 275.....	47
FFS/FSUFS 45 – 275 .....	26	Further details and options.....	48
FFS/FSUFA 280 – 450N .....	27	Notes .....	51
FFS/FSUFS 45 – 275 Assembly .....	28	Further designs and combinations .....	52
Notes .....	29	Installation and maintenance .....	56
FRR/FSURR 45 – 275 .....	30	Tabulation and figures.....	59
FRR/FSURR 280 – 450N .....	31	ATEX.....	62
FSV/FSUSV 45 – 275.....	32	Contact us.....	64





## We connect the world

We are more than a 75 years old family-owned company specialized in designing and manufacturing high-quality custom-made power transmission products.

Because we believe each transmission challenge is different, we create much more than off-the shelf products: we work hand in hand with our customers to develop the coupling solutions that best fit their specific needs.

Superior product quality is what guarantees our customer's success, it is what enables us to cherish long term partnerships with them. The ESCO quality has been worldly renown for decades and we work tirelessly to raise these standards even further.

We strive to be a significant contributor to the development of effective and clean industrial, transportation and energy supply applications. We want our couplings to power a more sustainable world.

We strongly believe that both the future of our economy and the best guarantee for long term return lie in sustainable development. And we want to do our part.

Once we get involved into a specific sector, we make sure to embrace the quality standards that the market requires. This is why, we are ISO 9001 certified.



A global footprint, with a family of  
9 companies located all across the world



9

offices across  
the world

3

manufacturing  
sites

● ESCO Couplings SRL  
*Saintes, Belgium*  
Tel. +32 (0) 2 715 65 60  
info@esco-couplings.be

● ESCO Couplings & Transmissions Pvt. Ltd.  
*Bengaluru, India*  
Tel. +91 80 7100 1800  
info@esco-couplings.co.in

● ESCO Power SRL  
*Saintes, Belgium*  
Tel. +32 (0) 2 717 64 90  
info@escopower.be

● EFECO Services Pvt. LTd  
*Bengaluru, India*  
Tel. +91 80 4977 7088

● ESCO Couplings Ltd.  
*Jinan, China*  
Tel. 86 (531) 827 625 65  
info@esco-couplings.com



- Head-office & Manufacturing site
- Manufacturing sites
- Sales offices & Service centres

● ESCO Aandrijvingen B.V.  
*Alphen A/D Rijn, The Netherlands*  
Tel. +31 (0) 172 42 33 33  
[info@esco-aandrijvingen.nl](mailto:info@esco-aandrijvingen.nl)

● esco antriebstechnik gmbh  
*Troisdorf, Germany*  
Tel. +49 (0) 2241 48 07 0  
[info@esco-antriebstechnik.com](mailto:info@esco-antriebstechnik.com)

● ESCO Drives SRL  
*Saintes, Belgium*  
Tel. +32 (0) 2 717 64 60  
[sales@esco.be](mailto:sales@esco.be)

● ESCO Transmissions SAS.  
*Saint Witz, France*  
Tel. +33 (1) 34 31 95 95  
[info@esco-transmissions.fr](mailto:info@esco-transmissions.fr)

We work with you to design the right  
solution for your application





---

Versatility, robustness, efficiency and long life, these are only a few of the many high demands on the gear couplings. These properties are the reason why gear couplings are that popular in multiple industries as they can get along with all different harsh conditions.

---

Since the competitiveness of the technical and economic aspects of the production needs to be more and more effective in the long-term, the machines used in the applications need to be able to run continuously, without failure. Furthermore, maintenance operations should be as short and seamless as possible to minimize costly production down time.

Minimizing the life cycle cost of the installation requires careful attention when selecting the elements of the driveline. A high-quality coupling will make a difference between an efficient, cost effective transmission, and a poorly optimized one.

This is where ESCO can help you. We have been helping our customers by designing high-quality tailor-made couplings for more than 40 years:

**Quality is our motto, our core competency:** ESCO products are amongst the most reliable in the market; so much so that the main hurdle in our capacity to innovate is the lack of market feedback: our couplings just keep running without issues.

**Low lifecycle cost might well be the biggest challenge for ESCO to tackle, but we do work tirelessly to optimize the life time value of our couplings:** fair initial price, smaller footprint (space and weight), longer design life, lubrication-free alternatives, extended maintenance steps...

**Service is an important part of our business:** to best serve your needs, you can count on our experienced team and advanced testing capability. We are more than happy to assist in performing field interventions, maintenance and repair.

Our relationship with customers does not stop once couplings are delivered. We have a team of experienced people ready to perform service on the field, repair, inspections, testing... We can also do the maintenance on our couplings for you. This guarantees proper execution of the maintenance instructions and contributes to improving the lifetime of your application.

**ESCO specializes in the design of custom made couplings. If you cannot find a solution that fits your needs, please contact us: we will work hard to engineer the coupling that fits your application specifications.**

# Why ESCOGEAR F?

---

## Improves efficiency of machine design and coupling selection

---

### High torque and misalignment capacity – Compact design

Thanks to the patented ESCOGEAR Multicrown profile (used on the F and C...M series), the optimized coupling design and the standard use of 12.9 quality bolts, the ESCOGEAR couplings offer the user a very high torque capacity. This means that for a given torque a smaller coupling can be used which results in more efficient machine design and performance. Furthermore, this high torque is available at important angular misalignment.

### Torque capacity independent from misalignment – Transparent coupling selection

The torque capacity of a gear type coupling strongly depends on the angular misalignment to which it is subjected: the higher the misalignment, the lower the torque capacity. It is clear that this relationship can and will cause problems in coupling selection because misalignment during operation is almost impossible to predict. ESCOGEAR couplings of the F and C...M types are equipped with the ESCO Multicrown tooth form. Thanks to this quite unique design, the ESCOGEAR has a torque capacity that is practically independent of the angular misalignment. Therefore, coupling selection is easy and mistakes are avoided: long coupling life is guaranteed.

---

## Extends installation lifetime

---

### High precision gearing – Higher quality, more reliable coupling

Pitch error in the gearing of coupling can strongly affect the load distribution between the teeth can be strongly influenced. In some cases, the maximum load applied on the teeth can be twice the value of the load calculated. The consequence will be higher surface and root stresses and coupling failure might be the result. Thanks to the high precision manufacturing process and equipment on which all ESCOGEAR couplings are manufactured and the sophisticated quality control, pitch error is minimized and the best possible gear quality level and life time can be guaranteed.

### Reduced backlash – Reduced load during start/stop and reverse torque applications

Due to the Multicrown design necessary backlash between the teeth can be reduced to an absolute minimum. This will reduce the impact loads in start/stop and reverse torque applications. As a result, the teeth can be designed with a larger profile and the root stresses will be reduced. Thanks to this feature the ESCOGEAR couplings are ideal for use in presses, mills, punching machines, portal cranes, pumps, conveyors etc...

### Perfect gear top centering – Reduced vibrations

Gear type couplings require, in order to operate, a “clearance” between the top of each hub tooth and the root of the sleeve teeth. Due to this clearance, the sleeve cannot be perfectly centred on the hubs. This will create vibrations in applications where the load constantly changes from no load to full load (e.g. portal cranes). These vibrations will of course influence the operation of the connected equipment. Thanks to special design and machining techniques, ESCO is able to pilot the top of each hub tooth into the root of the sleeve teeth. By doing so, the sleeve will remain perfectly centred on the hub and vibrations will be avoided. This specific feature is standard on all F and C...M couplings.

### Special surface treatment and coating – Excellent protection of components

In order to guarantee optimum operation, all ESCOGEAR couplings are protected with special surface treatment or coating. All bolts are coated with Geomet and the nuts are zinc plated which gives an excellent corrosion resistance and makes disassembly possible, even after numerous years of service life. Furthermore, all the steel components are protected with a special coating to improve their corrosion resistance.

# FST

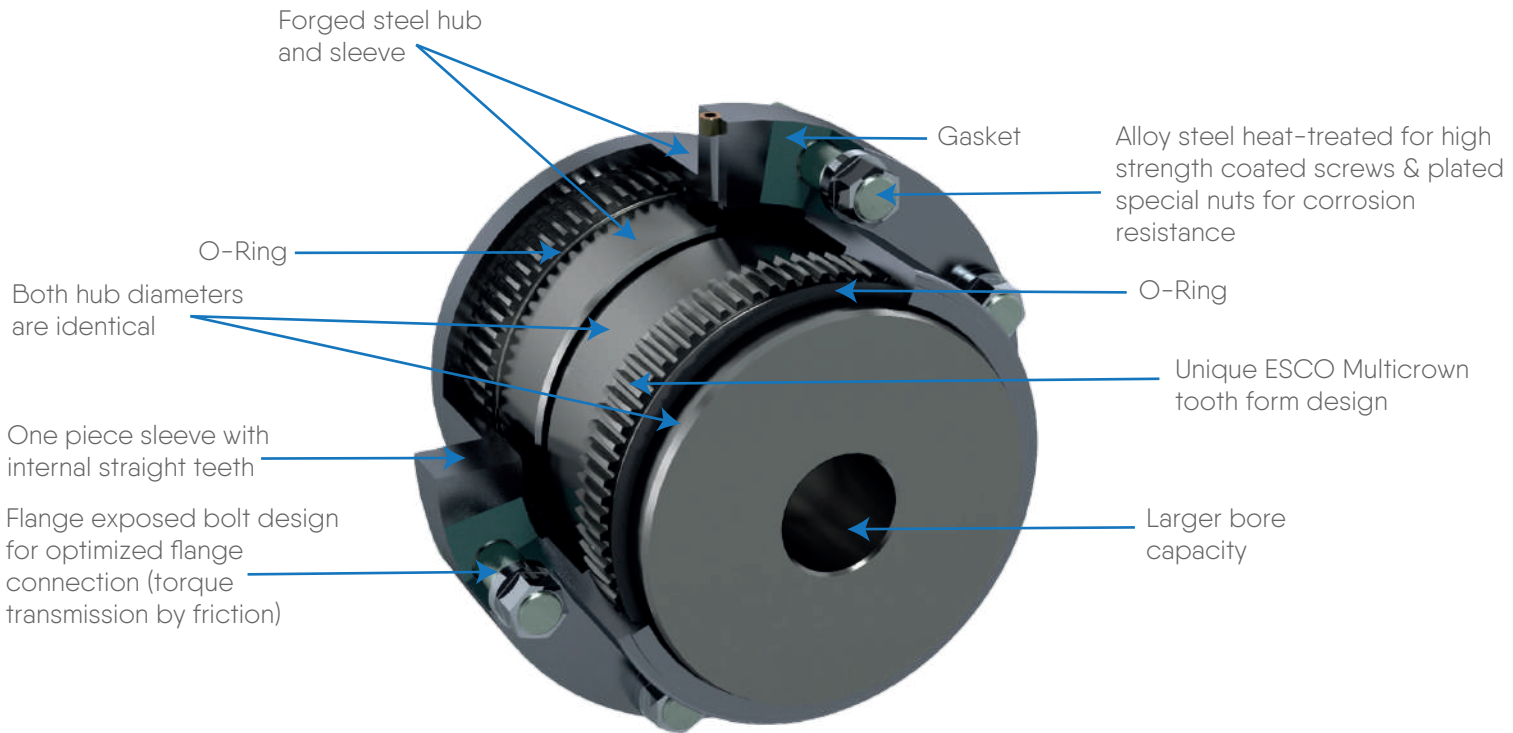

## ESCO Multicrown tooth form design: Technical features

### Lower stresses

The ESCO Multicrown tooth form is a curve with constantly changing radii of curvature. The tooth contact area under misaligned conditions has a much larger radius of curvature than conventional crowning. The contact area therefore is larger thus reducing the surface stresses.

### Constant velocity power transmission

ESCO generates the ESCO Multicrown tooth in such a way that the necessary characteristics for homokinetic conjugate tooth action are perfectly achieved.

### Less backlash

The ESCO Multicrown tooth design requires less backlash for a given angle of misalignment than the conventional crowning, thus reducing shocks in reversing application.

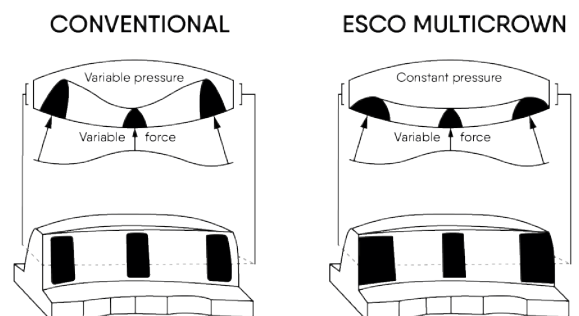
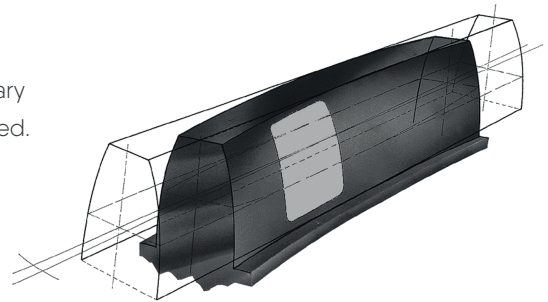

## Availabilities

ESCO proposes a range of couplings available with Exposed Metric (EM) or Exposed Inch (IM) bolts and nuts.

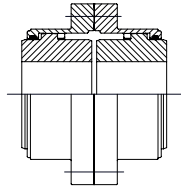

FST/FSU  
STANDARD  
C4100a + C4110a  
Page 18 & 19

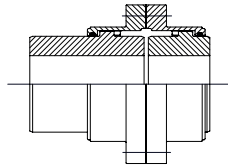

FMM/FSUMM  
MILL MOTOR  
C4140a + C4141a  
Page 20 & 21

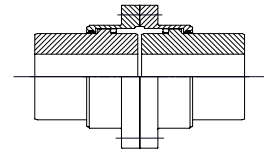

FDMM/FSUDMM  
DOUBLE MILL MOTOR  
C4150a + C4151a  
Page 22 & 23

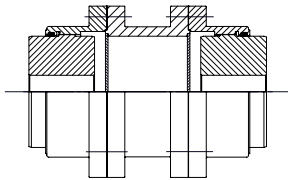

FSE/FSUSE  
SPACER EXECUTION  
C4130a + C4131a  
Page 24 & 25

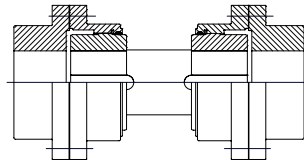

FFS/FSUFS  
FLOATING SHAFT  
C4120a + C4121a + C4122a  
Page 26 & 27 & 28

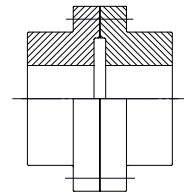

FRR/FSURR  
RIGID RIGID  
C4210a + C4211a  
Page 30 & 31

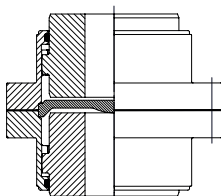

FSV/FSUSV  
STANDARD VERTICAL  
C4190a + C4191a  
Page 32 & 33

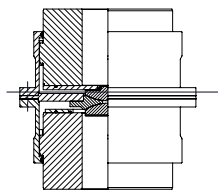

FSVA/FSUSVA  
STANDARD VERTICAL WITH AXIAL LOAD  
C4195a + C4196a  
Page 34 & 35

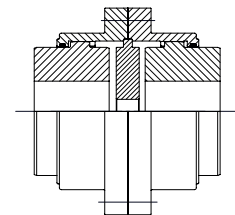

FST-SHSD/FSUSHSD  
STANDARD HUB SMALL DBSE  
C4250a  
Page 36

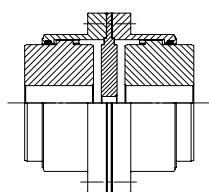

FST-SHLD/FSUSHLD  
STANDARD HUB LARGE DBSE  
C4255a  
Page 37

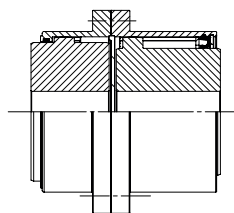

FSH/FSUSH  
SLIDING HUB  
C4160a  
Page 38

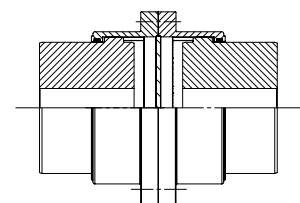

FDSH/FSUDSH  
DOUBLE SLIDING HUB  
C4165a  
Page 39

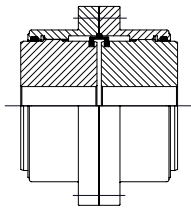

FLE/FSULE  
LIMITED END FLOAT  
C4170a  
Page 40

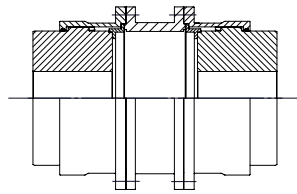

FSELE/FSUSELE  
SPACER EXECUTION, LIMITED END FLOAT  
C4200a  
Page 41

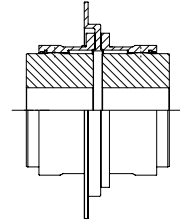

FBD/FSUBD  
BRAKE DISC  
C4260a  
Page 42

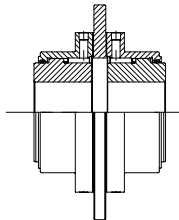

FBDS/FSUBDS  
BRAKE DISC STRAIGHT  
C4263a  
Page 43

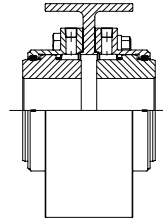

FBP/FSUBP  
BRAKE PULLEY  
C4266a  
Page 44

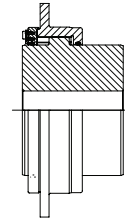

FWD  
WINCH DRUM  
C4220a  
Page 45

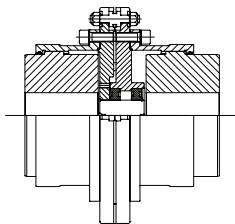

FSP/FSUSP  
SHEAR PIN  
C4180a  
Page 46

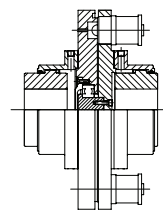

FET/FSUET  
ESCO TORQUE  
C4230a  
Page 47

In the follow-up you will find the chapters "Further details and options" and "Further design and combinations" for more information.

## How to select the right coupling size

### Coupling size selection

To be sure to select the right ESCOGEAR F coupling for your application, it is necessary to know the following preliminary data:

- The shaft diameter
- The duration and type of the daily service
- The type of driving machine
- The application peak torque
- The type of driven machine
- The presence of shocks or very high load peaks

To select the right ESCOGEAR F coupling size, please follow these steps:

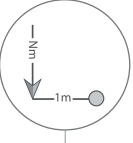
- 

Calculate the required torque capacity by using this formula:  $T = \frac{9550 \times P \times F_u}{n}$  with:

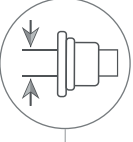
  - a. P, power in kW
  - b. n, speed in rpm
  - c. Fu, service factor according to the application (see TABLE 1).
- 

Select the size of ESCOGEAR F coupling that will accommodate the largest shaft diameter (see Technical data tables, Ød max. = Maximum possible bore).
- 

Make sure the selected coupling has an equal or greater torque capacity than the result figure obtained in ①. If it is not the case to be used, please select a larger size coupling.

  - Check if the application peak torque does not exceed the chosen coupling peak torque (see Technical data tables, Tp = Maximum peak torque).
  - Check the maximum allowable misalignment using the graph of (see TABLE 2).
  - Check if the shaft/hub connection will transmit the torque.  
If necessary, select a longer hub.
- 

Read carefully the Assembly and Maintenance Instructions IM/B400a

Table 1: Service factor ( $F_u$ )

For ATEX applications the minimum Service Factor ( $F_u$ ) should be 2.0 independently of the below given values.

Applications		DRIVER MACHINE			
		Electric motors & Turbines	Hydraulic motors & Gear drivers	Reciprocating engine & Electric motors frequent starts	
		Service Factor $F_u$			
DRIVEN MACHINES	UNIFORM	Generators - Blowers: centrifugal vanes, fans - Centrifugal pumps & compressors - Machine tools: auxiliary drives - Conveyors: belt and chain, uniformly loaded, escalators - Can filling machines & bottling machinery - Agitators: pure liquids	0.8 to 1.25	1 to 1.5	1.25 to 1.75
		Propellers - Waterjet pumps	1.25	1.5	1.75
	MODERATE SHOCKS	Blowers: lobe - Pumps: gear and lobe types - Vane compressors - Machine tools: main drives - Conveyors: belt & chain not uniformly fed bucket & screw - Elevators, cranes, tackles & winches - Wire winding machines, reels, winders (paper industry) - Agitators: liquids and solids, liquids of variable density	1.25 to 1.5	1.5 to 1.75	1.75 to 2
	HEAVY SHOCKS	Generators (welding) - Reciprocating pumps & compressors - Laundry washers - Bending roll, punch press, tapping machines - Barkers, calenders, paper presses - Briquetter machines, cement furnace - Crushers: ore & stone, hammer mill, rubber mill - Metal mills: forming machines, table conveyors - Draw bench, wire-drawing & flattening machines - Road & railroad equipment	1.5 to 2	1.75 to 2.25	2 to 2.5

1) Maximum misalignment

Table 2: Graph (T,n)

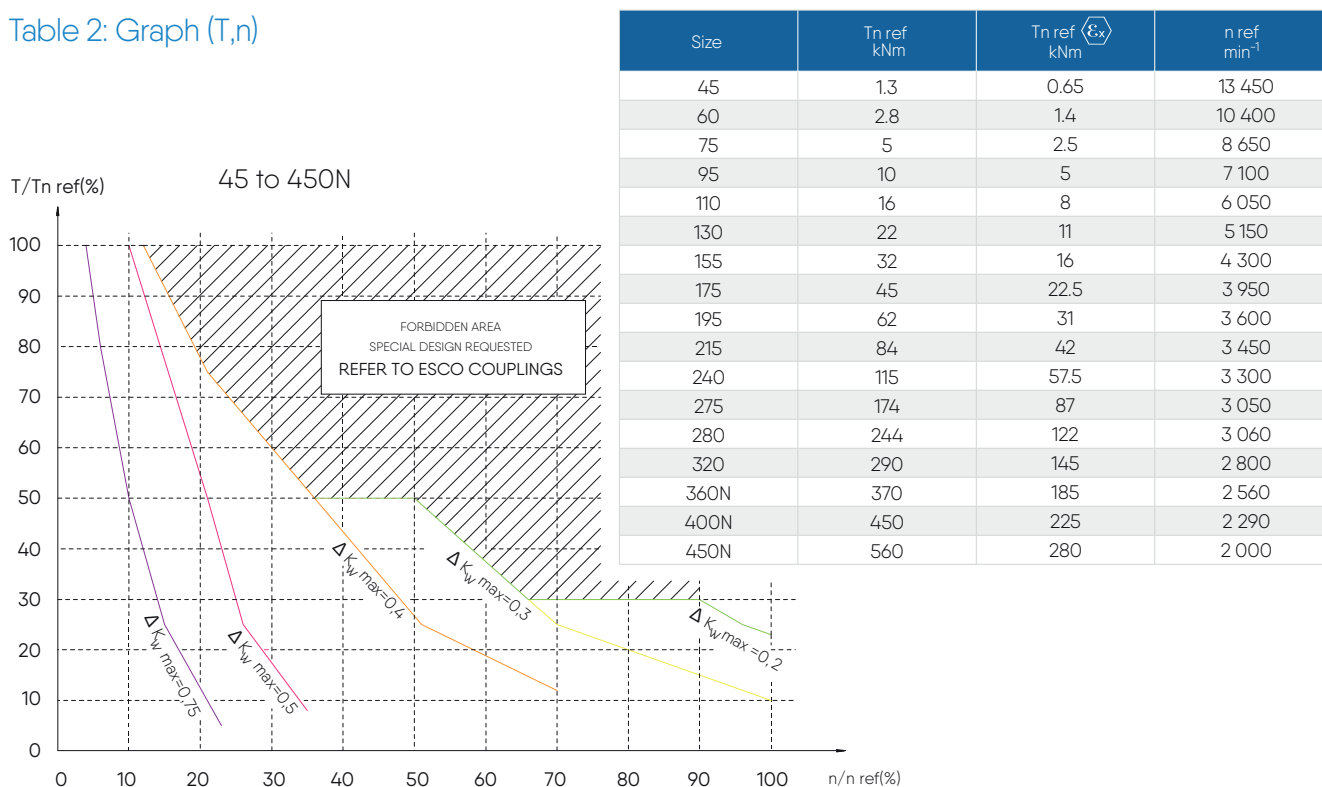

How to use this graph (T,n)?

Maximum torque, maximum speed and maximum misalignment may not occur simultaneously.

1. Calculate Tn (nominal torque) and Tp (peak torque) and select coupling size.
2. Calculate Tn / Tn ref and n/n ref and plot the resulting point in the graph.
3. If the resulting point is located in the white area, a standard coupling may be used as far as maximum misalignment does not exceed the minimum misalignment indicated in the graph.
4. If the resulting point is located in the shaded area, please refer to ESCO Couplings.
5. In case of use in potentially explosive atmospheres  $\langle \text{Ex} \rangle$ , proceed with the same way but using Tn ref  $\langle \text{Ex} \rangle$  for the calculation. Maximum misalignment may not exceed 0.5° per gear mesh.

## 2) Minimum misalignment:

To ensure proper gear lubrication =  $\Delta K_w \min = 0.1^\circ$

## 3) Misalignment control:

- Measure X (Total Indicator Readout - TIR)
- Measure Y - Z
- Verify the relationship for the misalignment control:

$$\Delta K_w \min \leq \frac{X}{K_x} + \frac{Y - Z}{K_y} \leq 0.75 \times \Delta K_w \max$$

$$K_x = K_{x0} + \frac{S}{30} \text{ with } S = \text{Spacer length (mm)}$$

(If no spacer: S=0)

$$K_y = K_{y0}$$

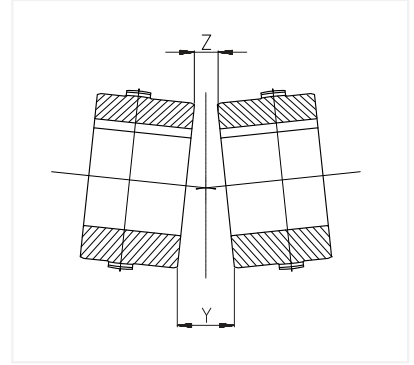
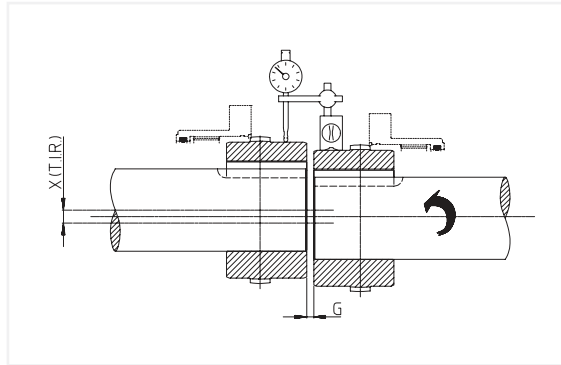

## 4) Examples:

- Example of calculation:
 
$$\left. \begin{array}{l} T/Tn \text{ ref} = 30\% \\ n/n \text{ ref} = 30\% \end{array} \right\} \Delta K_w \max = 0.4^\circ$$
 FST 175:  $K_x = 5.72$   $K_y = 8.2$
- Example of measurement:
 
$$X \text{ (TIR)} = 0.9 \text{ mm} \quad Y - Z = 0.4 \text{ mm}$$

- Example of control:
 
$$\text{Formula: } \Delta K_w \min \leq \frac{X}{K_x} + \frac{Y - Z}{K_y} \leq 0.75 \times \Delta K_w \max$$

$$\text{Calculation: } 0.1^\circ \leq \frac{0.9}{5.7} + \frac{0.4}{8.2} \leq 0.75 \times 0.4$$

FST	$K_{x0}$	$K_{y0}$
45	1.92	2.34
60	2.06	3.04
75	2.76	3.71
95	3.25	4.54
110	3.80	5.28
130	4.47	6.22
155	5.03	7.55
175	5.72	8.20
195	6.35	9.18
215	7.47	9.98
240	8.24	11.04
275	9.18	12.98
280	10.82	13.76
320	11.34	15.08
360	12.32	16.76
400	13.37	18.50
450	14.35	20.74

Notes:

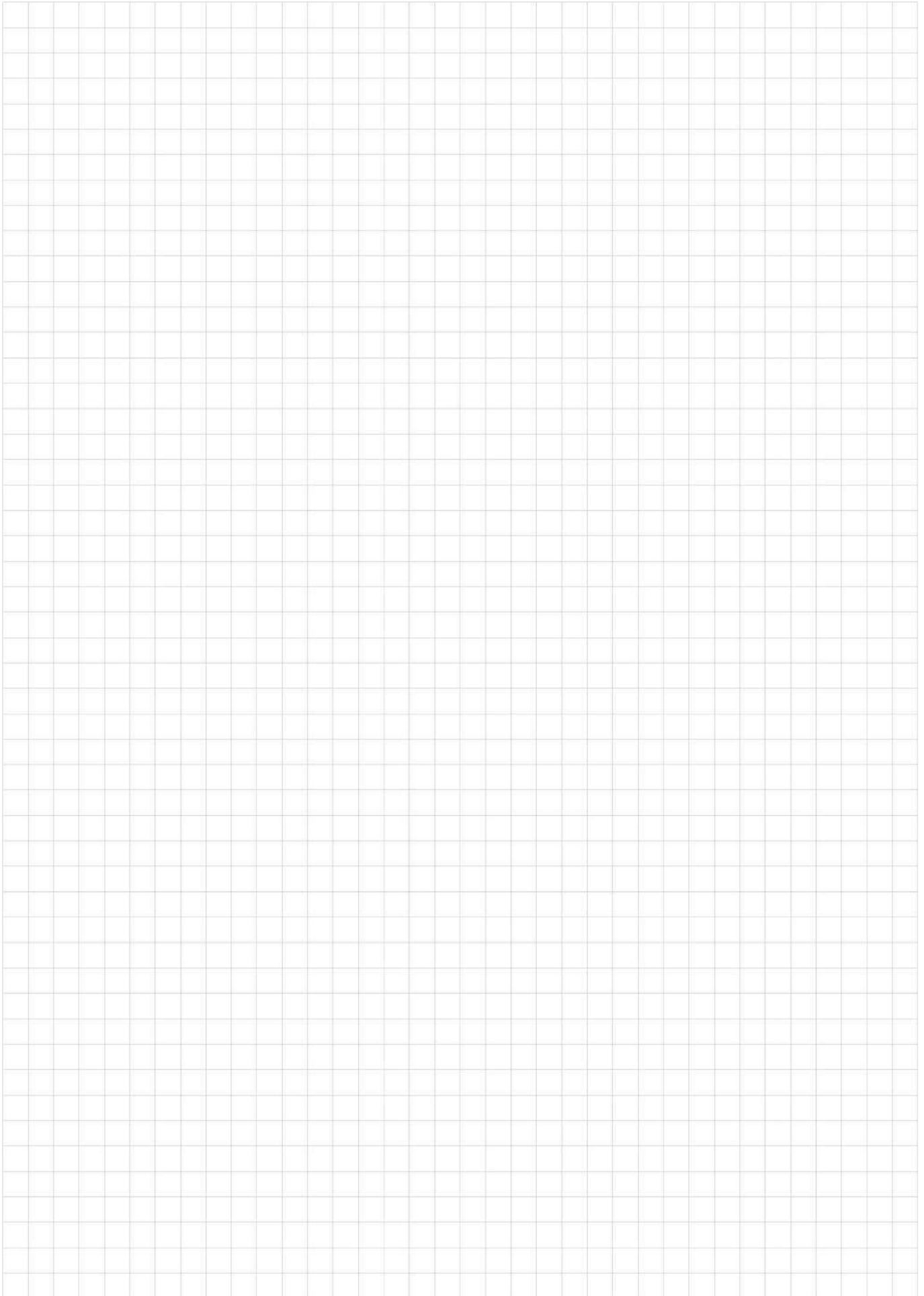

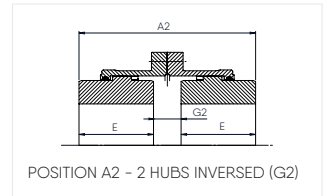
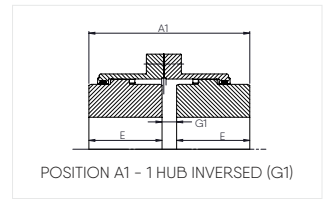
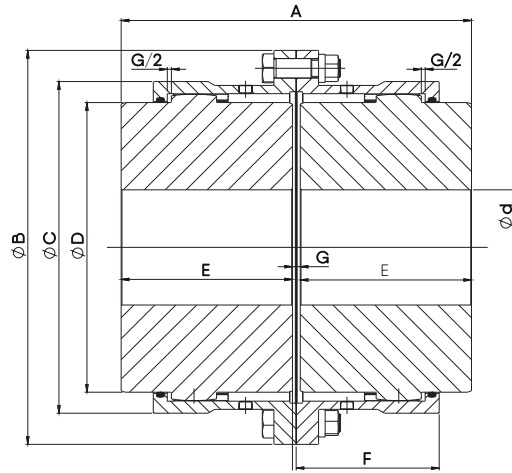

size	torque FST		torque FSUST (1)		n1 max.	n2 max. (2)	Ød min. (3)	Ød max. (4)	A	A1	A2	ØB	ØC	ØD	E	F	G	G1	G2	weight (5)	inertia J (5)	max. misalignment			
	nominal T <sub>n</sub>	peak T <sub>p</sub>	nominal T <sub>n</sub>	peak T <sub>p</sub>																		angular	radial	axial (+)	
FST FSUST	kNm	kNm	kNm	kNm	rpm	rpm	dimensions mm														kg	kgm <sup>2</sup>	degree	mm	mm
45	1.3	2.6	2.6	5.2	5 000	7 000	0	50	89	98	107	111	80	67	43	41	3	12	21	4.1	0.005	2x0.75	0.7	3.0	
60	2.8	5.6	5.6	11	4 400	6 200	0	64	103	109	115	141	103.5	87	50	47	3	9	15	8.0	0.015	2x0.75	0.8	3.0	
75	5.0	10	10	20	4 000	5 650	0	78	127	141	155	171	129.5	106	62	58.5	3	17	31	15	0.041	2x0.75	1.0	3.0	
95	10	20	20	40	3 600	5 100	0	98	157	169	181	210	156	130	76	69	5	17	29	26	0.109	2x0.75	1.2	5.0	
110	16	32	32	64	3 350	4 700	0	112	185	199	213	234	181	151	90	82	5	19	33	39	0.191	2x0.75	1.4	5.0	
130	22	44	44	88	3 100	4 350	55	132	216	233	250	274	209	178	105	98	6	23	40	60	0.436	2x0.75	1.6	6.0	
155	32	64	64	128	2 800	4 000	65	158	246	264	282	312	247	213	120	108.5	6	24	42	90	0.854	2x0.75	1.8	6.0	
175	45	90	90	180	2 700	3 800	80	175	278	299	320	337	273	235	135	121	8	29	50	115	1.32	2x0.75	2.0	8.0	
195	62	124	124	248	2 550	3 600	90	198	308	332	356	380	307	263	150	132	8	32	56	166	2.43	2x0.75	2.4	8.0	
215	84	168	168	336	2 450	3 450	100	217	358	389	420	405	338	286	175	151.5	8	39	70	219	3.69	2x0.75	2.8	8.0	
240	115	230	230	460	2 300	3 300	120	244	388	426	464	444	368	316	190	165	8	46	84	275	5.37	2x0.75	3.0	8.0	
275	174	348	348	696	2 150	3 050	150	290	450	483	516	506	426	372	220	183.5	10	43	76	411	11	2x0.75	3.4	10	

- (1) Uprated torque execution
- (2) Special balancing recommended and use of high speed grease
- (3) Min. finish machine bore diameter (size ≥ 130)
- (4) Max. bore diameter with one keyway acc. DIN 6885/1
- (5) For pre-bored/unbored hubs

- Couplings can be supplied with several options (e.g. end cap, puller holes, set screws, exposed inch, ATEX, Viton O-Ring, surface protection) → refer to page 48 et seqq. (B403a et seqq.)
- For the correct coupling selection please refer to page 14 et seqq. (A150a)
- For special executions or requirements, please contact us
- Technical modifications reserved and given values without engagement

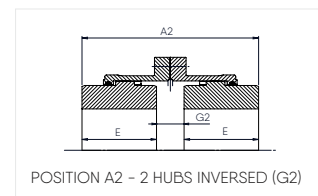
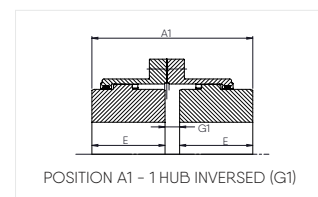
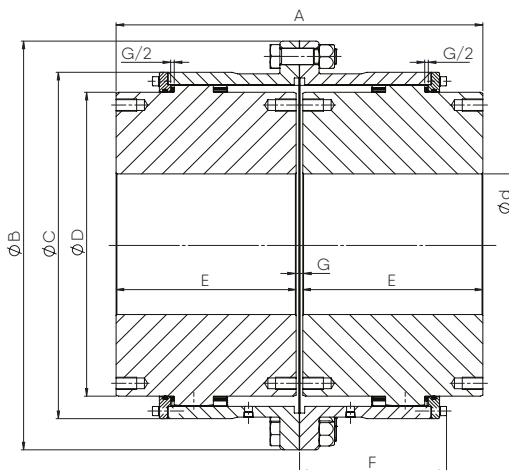

size	torque FST		torque FSUST (1)		n1 max.	Ød min. (2)	Ød max. (3)	A	A1	A2	ØB	ØC	ØD	E	F	G	G1	G2	weight (4)	inertia J (4)	max. misalignment			
	nominal Tn	peak Tp	nominal Tn	peak Tp																	angular	radial	axial (±)	
FST FSUST	kNm	kNm	kNm	kNm	rpm	dimensions mm														kg	kgm <sup>2</sup>	degree	mm	mm
280	244	488	488	976	1900	180	310	570	590	610	591	470	394	280	226.5	10	30	50	591	20.0	2x0.75	4.0	10	
320	290	580	580	1160	1800	200	340	597	617	637	640	518.5	432	292	236	13	33	53	764	30.0	2x0.75	4.4	13	
360N	370	740	740	1480	1500	220	375	623	658	693	684	562	480	305	253	13	48	83	932	45.0	2x0.75	4.6	13	
400N	450	900	900	1800	1400	257	420	673	713	753	742	620	530	330	272	13	53	93	1197	69.0	2x0.75	5.0	13	
450N	560	1120	1120	2240	1300	277	470	713	761	809	804	682	594	350	286	13	61	109	1532	105	2x0.75	5.4	13	
500	630	1260	1260	2520	1150	300	500	759	811	863	908	733	629	370	299	19	71	123	1952	163	2x0.75	5.6	19	
530	750	1500	1500	3000	1050	330	530	809	865	921	965	787	673	395	317	19	75	131	2230	228	2x0.75	6.0	19	
560	860	1720	1720	3440	900	350	560	895	919	979	1029	841	724	420	331	19	79	139	2849	306	2x0.75	6.4	19	
600	1020	2040	2040	4080	800	380	600	905	969	1033	1092	892	772	440	359	25	89	153	3377	419	2x0.75	6.8	25	
660	1290	2580	2580	5160	550	420	660	920	990	1060	1200	997	870	460	375	25	95	165	4860	674	2x0.75	7.2	25	
730	2020	4040	4040	8080	450	480	730	1105	1180	1255	1330	1130	965	540	405	25	100	175	6357	1209	2x0.75	7.2	25	
830	2450	4900	4900	9800	380	540	830	1180	1260	1340	1440	1240	1062	590	448	25	105	185	8320	1772	2x0.75	7.2	25	
900	3070	6140	6140	12280	325	580	900	1260	1345	1430	1545	1345	1156	630	483	25	110	195	10250	2560	2x0.75	7.2	25	
1000	3610	7220	7220	14400	280	640	1000	1340	1430	1520	1650	1540	1254	670	528	25	115	205	12450	4190	2x0.75	7.2	25	
1060	4390	8780	8780	17560	240	680	1060	1380	1475	1570	1750	1550	1346	690	538	25	120	215	14800	4890	2x0.75	7.2	25	
1130	5040	10080	10080	20160	220	740	1130	1400	1500	1600	1860	1660	1448	700	548	25	125	225	17700	6690	2x0.75	7.2	25	

- (1) Uprated torque execution
- (2) Min. finish machine bore diameter
- (3) Max. bore diameter with one keyway acc. DIN 6885/1
- (4) For pre-bored/unbored hubs

- Couplings can be supplied with several options (e.g. end cap, puller holes, set screws, exposed inch, ATEX, Viton O-Ring, surface protection) → refer to page 48 et seqq. (B403a et seqq.)
- For the correct coupling selection please refer to page 14 et seqq. (A150a)
- For special executions or requirements, please contact us
- Technical modifications reserved and given values without engagement

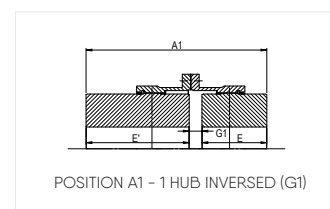
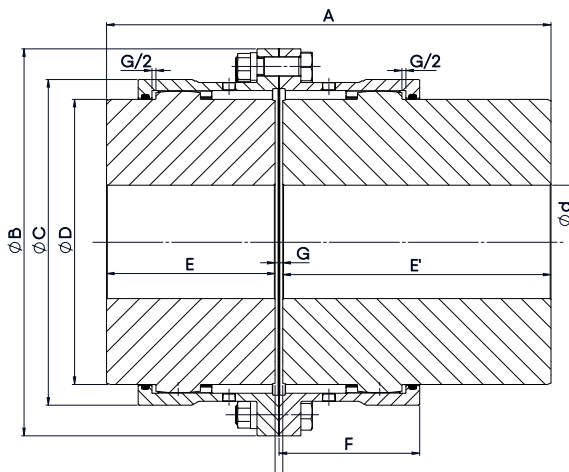

size	torque FMM		torque FSUMM (1)		n1 max.	n2 max. (2)	Ød min. (3)	Ød max. (4)	A	A1	ØB	ØC	ØD	E	E'	F	G	G1	weight (5)	inertia J (5)	max. misalignment		
	nominal Tn	peak Tp	nominal Tn	peak Tp																	angular	radial	axial (+)
FMM FSUMM	kNm	kNm	kNm	kNm	rpm	rpm	dimensions mm											kg	kgm²	degree	mm	mm	
45	1.3	2.6	2.6	5.2	5 000	7 000	0	50	126	135	111	80	67	43	80	41	3	12	5.1	0.005	2x0.75	0.7	3.0
60	2.8	5.6	5.6	11	4 400	6 200	0	64	167	173	141	103.5	87	50	114	47	3	9	11	0.019	2x0.75	0.8	3.0
75	5.0	10	10	20	4 000	5 650	0	78	195	209	171	129.5	106	62	130	58.5	3	17	19	0.047	2x0.75	1.0	3.0
95	10	20	20	40	3 600	5 100	0	98	227	239	210	156	130	76	146	68.5	5	17	34	0.124	2x0.75	1.2	5.0
110	16	32	32	64	3 350	4 700	0	112	260	274	234	181	151	90	165	82	5	19	50	0.226	2x0.75	1.4	5.0
130	22	44	44	88	3 100	4 350	55	132	281	298	274	209	178	105	170	98	6	23	71	0.493	2x0.75	1.6	6.0
155	32	64	64	128	2 800	4 000	65	158	316	334	312	247	213	120	190	108.5	6	24	106	0.964	2x0.75	1.8	6.0
175	45	90	90	180	2 700	3 800	80	175	343	364	337	273	235	135	200	121	8	29	137	1.47	2x0.75	2.0	8.0
195	62	124	124	248	2 550	3 600	90	198	378	402	380	307	263	150	220	132	8	32	193	2.68	2x0.75	2.4	8.0
215	84	168	168	336	2 450	3 450	100	217	433	464	405	338	286	175	250	151.5	8	39	255	4.10	2x0.75	2.8	8.0
240	115	230	230	460	2 300	3 300	120	244	478	516	444	368	316	190	280	165	8	46	323	6.04	2x0.75	3.0	8.0
275	174	348	348	696	2 150	3 050	150	290	580	613	506	426	372	220	350	183.5	10	43	508	12.5	2x0.75	3.4	10

- (1) Uprated torque execution
- (2) Special balancing recommended and use of high speed grease
- (3) Min. finish machine bore diameter (size ≥ 130)
- (4) Max. bore diameter with one keyway acc. DIN 6885/1
- (5) For pre-bored/unbored hubs

- Couplings can be supplied with several options (e.g. end cap, puller holes, set screws, exposed inch, ATEX, Viton O-Ring, surface protection) → refer to page 48 et seqq. (B403a et seqq.)
- For the correct coupling selection please refer to page 14 et seqq. (A150a)
- For special executions or requirements, please contact us
- Technical modifications reserved and given values without engagement

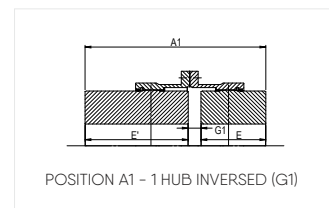
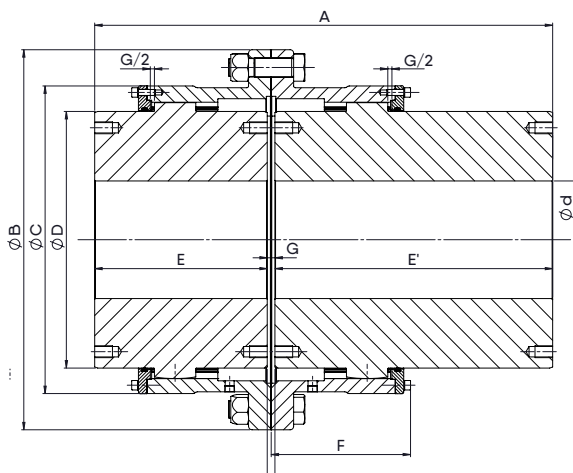

size	torque FMM		torque FSUMM (1)		n1 max.	Ød min. (2)	Ød max. (3)	A	A1	ØB	ØC	ØD	E	E'	F	G	G1	weight (4)	inertia J (4)	max. misalignment		
	nominal Tn	peak Tp	nominal Tn	peak Tp																angular	radial	axial (±)
FMM FSUMM	kNm	kNm	kNm	kNm	rpm	dimensions mm											kg	kgm <sup>2</sup>	degree	mm	mm	
280	244	488	488	976	1900	180	310	700	720	591	470	394	280	410	226.5	10	30	689	22.0	2x0.75	4.0	10
320	290	580	580	1160	1800	200	340	775	795	640	519	432	292	470	236	13	33	920	35.0	2x0.75	4.4	13
360N	370	740	740	1480	1500	220	375	788	823	684	562	480	305	470	253	13	48	1127	51.0	2x0.75	4.6	13
400N	450	900	900	1800	1400	260	420	893	933	742	620	530	330	550	272	13	53	1386	74.0	2x0.75	5.0	13
450N	560	1120	1120	2240	1300	280	470	913	961	804	682	594	350	550	286	13	61	1891	124	2x0.75	5.4	13

- (1) Uprated torque execution
- (2) Min. finish machine bore diameter
- (3) Max. bore diameter with one keyway acc. DIN 6885/1
- (4) For pre-bored/unbored hubs

- Couplings can be supplied with several options (e.g. end cap, puller holes, set screws, exposed inch, ATEX, Viton O-Ring, surface protection) → refer to page 48 et seqq. (B403a et seqq.)
- For the correct coupling selection please refer to page 14 et seqq. (A150a)
- For special executions or requirements, please contact us
- Technical modifications reserved and given values without engagement

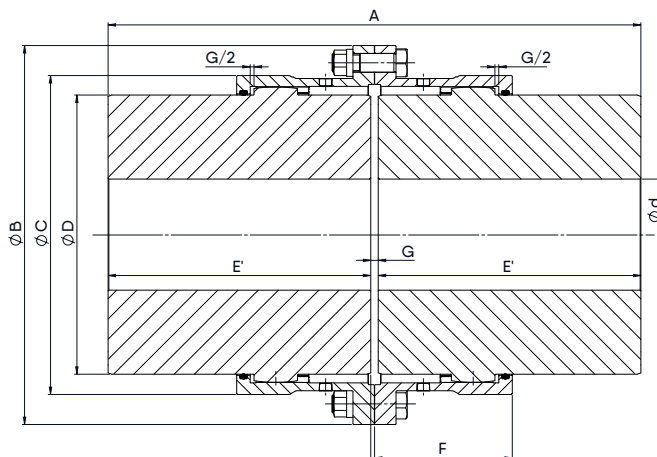

size	torque FDMM		torque FSUDMM (1)		n1 max.	n2 max. (2)	Ød min. (3)	Ød max. (4)	A	ØB	ØC	ØD	E'	F	G	weight (5)	inertia J (5)	max. misalignment		
	nominal T <sub>n</sub>	peak T <sub>p</sub>	nominal T <sub>n</sub>	peak T <sub>p</sub>														angular	radial	axial (±)
FDMM FSUDMM	kNm	kNm	kNm	kNm	rpm	rpm	dimensions mm									kg	kgm <sup>2</sup>	degree	mm	mm
45	1.3	2.6	2.6	5.2	5 000	7 000	0	50	163	111	80	67	80	41	3	6.1	0.006	2x0.75	0.7	3.0
60	2.8	5.6	5.6	11	4 400	6 200	0	64	231	141	103.5	87	114	47	3	14	0.018	2x0.75	0.8	3.0
75	5.0	10	10	20	4 000	5 650	0	78	263	171	129.5	106	130	58.5	3	24	0.054	2x0.75	1.0	3.0
95	10	20	20	40	3 600	5 100	0	98	297	210	156	130	146	68.5	5	41	0.140	2x0.75	1.2	5.0
110	16	32	32	64	3 350	4 700	0	112	335	234	181	151	165	82	5	60	0.256	2x0.75	1.4	5.0
130	22	44	44	88	3 100	4 350	55	132	346	274	209	178	170	98	6	83	0.543	2x0.75	1.6	6.0
155	32	64	64	128	2 800	4 000	65	158	386	312	247	213	190	108.5	6	125	1.07	2x0.75	1.8	6.0
175	45	90	90	180	2 700	3 800	80	175	408	337	273	235	200	121	8	152	1.62	2x0.75	2.0	8.0
195	62	124	124	248	2 550	3 600	90	198	448	380	307	263	220	132	8	218	2.94	2x0.75	2.4	8.0
215	84	168	168	336	2 450	3 450	100	217	508	405	338	286	250	151.5	8	285	4.45	2x0.75	2.8	8.0
240	115	230	230	460	2 300	3 300	120	244	568	444	368	316	280	165	8	364	6.72	2x0.75	3.0	8.0
275	174	348	348	696	2 150	3 050	150	290	710	506	426	372	350	183.5	10	598	14.4	2x0.75	3.4	10

- (1) Uprated torque execution
- (2) Special balancing recommended and use of high speed grease
- (3) Min. finish machine bore diameter (size ≥ 130)
- (4) Max. bore diameter with one keyway acc. DIN 6885/1
- (5) For pre-bored/unbored hubs

- Couplings can be supplied with several options (e.g. end cap, puller holes, set screws, exposed inch, ATEX, Viton O-Ring, surface protection)  
→ refer to page 48 et seqq. (B403a et seqq.)
- For the correct coupling selection please refer to page 14 et seqq. (A150a)
- For special executions or requirements, please contact us
- Technical modifications reserved and given values without engagement

FDMM/FSUDMM  
**DOUBLE MILL MOTOR**  
 280 ➤ 450N

C4151a

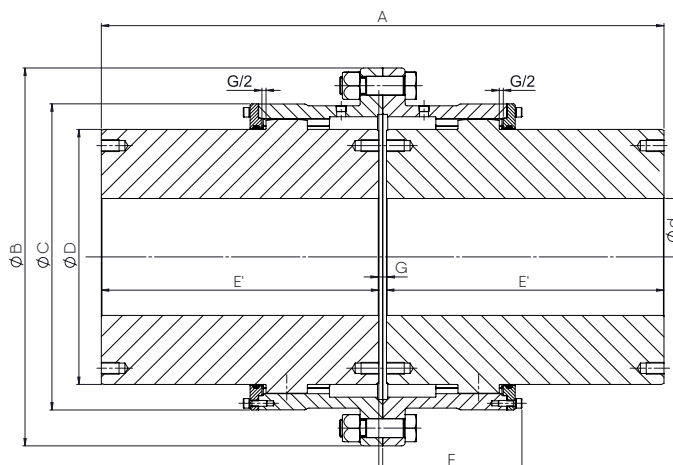

size	torque FDMM		torque FSUDMM (1)		n max.	Ød min. (2)	Ød max. (3)	A	ØB	ØC	ØD	E'	F	G	weight (4)	inertia J (4)	max. misalignment		
	nominal T <sub>n</sub>	peak T <sub>p</sub>	nominal T <sub>n</sub>	peak T <sub>p</sub>													angular	radial	axial (±)
FDMM FSUDMM	kNm	kNm	kNm	kNm	rpm	dimensions mm									kg	kgm <sup>2</sup>	degree	mm	mm
280	244	488	488	976	1900	180	310	830	591	470	394	410	227	10	787	24.7	2x0.75	4.0	10
320	290	580	580	1160	1800	200	340	953	640	519	432	470	236	13	1086	40.2	2x0.75	4.4	13
360N	370	740	740	1480	1500	220	375	953	684	562	480	470	253	13	1312	57	2x0.75	4.6	13
400N	450	900	900	1800	1400	260	420	1113	742	620	530	550	272	13	1587	83	2x0.75	5.0	13
450N	560	1120	1120	2240	1300	280	470	1113	804	682	594	550	286	13	2230	141	2x0.75	5.4	13

(1) Uprated torque execution

(2) Min. finish machine bore diameter

(3) Max. bore diameter with one keyway acc. DIN 6885/1

(4) For pre-bored/unbored hubs

- Couplings can be supplied with several options (e.g. end cap, puller holes, set screws, exposed inch, ATEX, Viton O-Ring, surface protection)  
→ refer to page 48 et seqq. (B403a et seqq.)
- For the correct coupling selection please refer to page 14 et seqq. (A150a)
- For special executions or requirements, please contact us
- Technical modifications reserved and given values without engagement

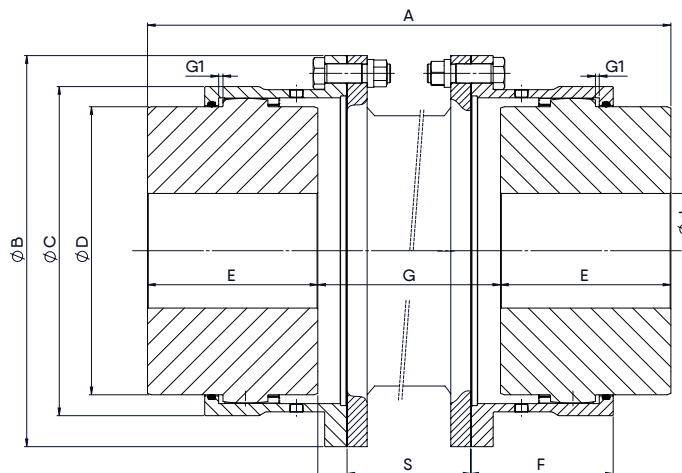

size	torque FSE		torque FSUSE (1)		n1 max. (2)	n2 max. (2/3)	Ød min. (4)	Ød max. (5)	A min.	ØB	ØC	ØD	E	F	G min.	G1	S min.	weight (6)		inertia J (6)		max. misalignment (7)	
	nominal Tn	peak Tp	nominal Tn	peak Tp														@ G min.	per 10 mm G increment	@ G min.	per 10 mm G increment	angular	axial (±)
FSE FSUSE	kNm	kNm	kNm	kNm	rpm	rpm	dimensions mm										kg	kgm²		degree	mm		
45	1.3	2.6	2.6	5.2	5 000	7 000	0	50	167	111	80	67	43	41	81	1.5	60	4.4	0.006	0.060	0.001	2x0.75	3.0
60	2.8	5.6	5.6	11	4 400	6 200	0	64	195	141	104	87	50	47	95	1.5	80	13	0.030	0.300	0.001	2x0.75	3.0
75	5.0	10	10	20	4 000	5 650	0	78	245	171	130	106	62	58.5	121	1.5	90	16	0.050	0.160	0.001	2x0.75	3.0
95	10	20	20	40	3 600	5 100	0	98	291	210	156	130	76	68.5	139	2.5	110	40	0.190	0.660	0.003	2x0.75	5.0
110	16	32	32	64	3 350	4 700	0	112	323	234	181	151	90	82	143	2.5	110	42	0.220	0.230	0.002	2x0.75	5.0
130	22	44	44	88	3 100	4 350	55	132	380	274	209	178	105	98	170	3	130	82	0.720	0.720	0.007	2x0.75	6.0
155	32	64	64	128	2 800	4 000	65	158	412	312	247	213	120	108.5	172	3	130	118	1.320	3.13	0.054	2x0.75	6.0
175	45	90	90	180	2 700	3 800	80	175	450	337	273	235	135	121	180	4	130	147	1.920	3.31	0.069	2x0.75	8.0
195	62	124	124	248	2 550	3 600	90	198	516	380	307	263	150	132	216	4	160	215	3.650	1.41	0.029	2x0.75	8.0
215	84	168	168	336	2 450	3 450	100	217	580	405	338	286	175	151.5	230	4	160	275	5.240	4.50	0.138	2x0.75	8.0
240	115	230	230	460	2 300	3 300	120	244	624	444	368	316	190	165	244	4	160	332	7.350	2.82	0.054	2x0.75	8.0
275	174	348	348	696	2 150	3 050	150	290	676	506	426	372	220	183.5	236	5	160	481	13.800	6.68	0.326	2x0.75	10

(1) Up-rated torque execution

(2) Refer to table below "Max. speed function G"

(3) Special balancing recommended and use of high speed grease

(4) Min. finish machine bore diameter (size ≥ 130)

(5) Max. bore diameter with one keyway acc. DIN 6885/1

(6) For pre-bored/unbored hubs

(7) Max. radial misalignment = 0.013 x (G + K)

Where: G = required DBSE; K = coefficient as below

Size	G	Max. speed function G						
		1 000	1 500	2 000	3 000	4 000	5 000	6 000
45		7 000	4 621	2 549	1 112	619		
60		6 200	5 986	3 279	1 420	788	501	
75		5 650	5 650	3 987	1 726	959	609	
95		5 100	5 100	4 724	2 037	1 129	716	
110		4 700	4 700	4 700	2 505	1 388	880	608
130		4 350	4 350	4 350	3 020	1 665	1 053	726
155		4 000	4 000	4 000	3 547	1 956	1 237	852
175		3 800	3 800	3 800	3 800	2 177	1 377	949
195		3 600	3 600	3 600	3 600	2 504	1 577	1 084
215		3 450	3 450	3 450	3 450	2 722	1 715	1 179
240		3 300	3 300	3 300	3 300	2 901	1 837	1 267
275		3 050	3 050	3 050	3 050	3 050	2 145	1 478

K factor for max. radial misalignment
34
44
48
64
76
88
102
114
126
144
152
187

- Couplings can be supplied with several options (e.g. end cap, puller holes, set screws, exposed inch, ATEX, Viton O-Ring, surface protection) → refer to page 48 et seqq. (B403a et seqq.)
- For the correct coupling selection please refer to page 14 et seqq. (A150a)
- For special executions or requirements, please contact us
- Technical modifications reserved and given values without engagement

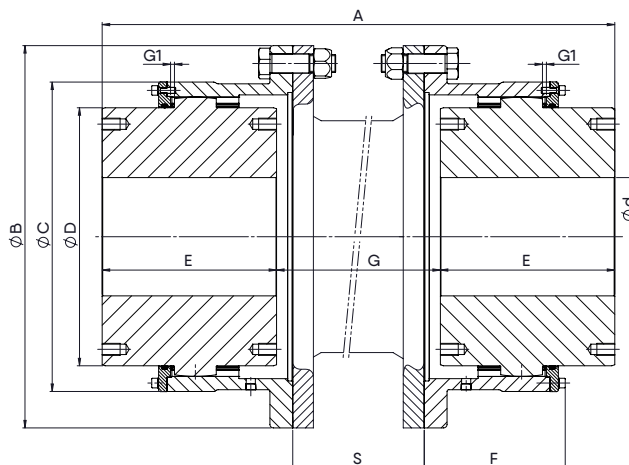

size	torque FSE		torque FSUSE (1)		n max. (2)	Ød min. (3)	Ød max. (4)	A min.	ØB	ØC	ØD	E	F	G min.	G1	S min.	weight (5)		inertia J (5)		max. misalignment (6)	
	nominal Tn	peak Tp	nominal Tn	peak Tp													@ G min.	per 10 mm G increment	@ G min.	per 10 mm G increment	angular	axial (±)
FSE FSUSE	kNm	kNm	kNm	kNm	rpm	dimensions mm										kg		kgm²		degree	mm	
280	244	488	488	976	1900	180	310	786	591	470	394	280	226.5	226	5	176	725	14	24.0	0.480	2x0.75	10
320	290	580	580	1160	1800	200	340	828	640	519	432	292	236	244	6.5	190	891	11	40.0	0.850	2x0.75	13
360N	370	740	740	1480	1500	220	375	883	684	562	480	305	253	273	6.5	190	1132	22	53.0	1.05	2x0.75	13
400N	450	900	900	1800	1400	260	420	943	742	620	530	330	272	283	6.5	190	1437	28	82.0	1.64	2x0.75	13
450N	560	1120	1120	2240	1300	280	470	999	804	682	594	350	286	299	6.5	190	1863	37	127.0	2.53	2x0.75	13

- (1) Up-rated torque execution
- (2) No lower limitation as first lateral critical speed is above n max. for all G < 5 000 mm
- (3) Min. finish machine bore diameter
- (4) Max. bore diameter with one keyway acc. DIN 6885/1
- (5) For pre-bored/unbored hubs
- (6) Max. radial misalignment = 0.013 x (G + K)

Where: G = required DBSE; K = coefficient as below

Size	K factor for max. radial misalignment
280	260
320	272
360N	270
400N	290
450N	302

- Couplings can be supplied with several options (e.g. end cap, puller holes, set screws, exposed inch, ATEX, Viton O-Ring, surface protection) → refer to page 48 et seqq. (B403a et seqq.)
- For the correct coupling selection please refer to page 14 et seqq. (A150)
- For special executions or requirements, please contact us
- Technical modifications reserved and given values without engagement

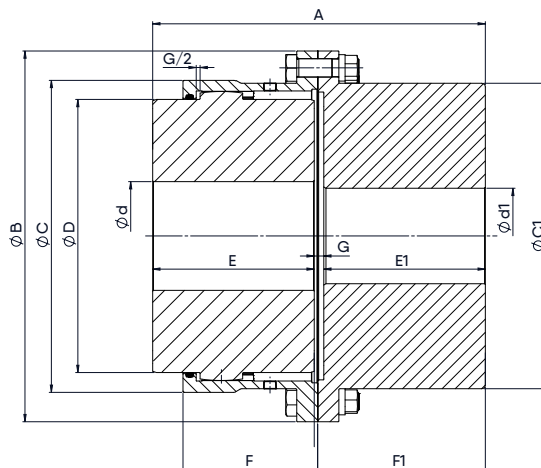

size	torque FFS		torque FSUFS (1)		n1 max	n2 max. (2)	Ød min. (3)	Ød max. (4)	Ød1 min. (3)	Ød1 max. (4)	A	ØB	ØC	ØC1	ØD	E	E1	F	F1	G	weight (5)	Inertia J (5)	max. misalignment		
	nominal Tn	peak Tp	nominal Tn	peak Tp																			angular	axial (±)	
FFS FSUFS	kNm	kNm	kNm	kNm	rpm	rpm	dimensions mm															kg	kgm²	degree	mm
45	1.3	2.6	2.6	5.2	5 000	7 000	0	50	0	55	88	111	80	80	67	43	40	41	43.5	5	4.2	0.005	0.75	1.5	
60	2.8	5.6	5.6	11	4 400	6 200	0	64	0	75	102	141	103.5	104	87	50	47	47	50.5	5	8.4	0.017	0.75	1.5	
75	5.0	10	10	20	4 000	5 650	0	78	0	95	125	171	130	126	106	62	58	58.5	61.5	5	15	0.041	0.75	1.5	
95	10	20	20	40	3 600	5 100	0	98	0	110	156	210	156	152	130	76	74	68.5	77.5	6	27	0.112	0.75	2.5	
110	16	32	32	64	3 350	4 700	0	112	0	130	183	234	181	178	151	90	87	82	90.5	6	40	0.204	0.75	2.5	
130	22	44	44	88	3 100	4 350	55	132	52	155	212.5	274	209	208	178	105	101	98	104.5	6.5	62	0.462	0.75	3.0	
155	32	64	64	128	2 800	4 000	65	158	62	180	239.5	312	247	245	213	120	113	108.5	116.5	6.5	90	0.882	0.75	3.0	
175	45	90	90	180	2 700	3 800	80	175	72	200	272	337	273	270	235	135	129	121	133	8	119	1.38	0.75	4.0	
195	62	124	124	248	2 550	3 600	90	198	82	230	308	380	307	305	263	150	150	132	154	8	174	2.60	0.75	4.0	
215	84	168	168	336	2 450	3 450	100	217	92	250	358	405	338	330	286	175	175	151.5	179	8	231	3.91	0.75	4.0	
240	115	230	230	460	2 300	3 300	120	244	102	280	390	444	368	362	316	190	190	165	196	10	285	5.76	0.75	4.0	
275	174	348	348	696	2 150	3 050	150	290	132	330	453	506	426	416	372	220	220	183.5	228	13	429	11.3	0.75	5.0	

- (1) Uprated torque execution
- (2) Special balancing recommended and use of high speed grease
- (3) Min. finish machine bore diameter (size ≥ 130)
- (4) Max. bore diameter with one keyway acc. DIN 6885/1
- (5) For pre-bored/unbored hubs

- Couplings can be supplied with several options (e.g. end cap, puller holes, set screws, exposed inch, ATEX, Viton O-Ring, surface protection) → refer to page 48 et seqq. (B403a et seqq.)
- For the correct coupling selection please refer to page 14 et seqq. (A150)
- For special executions or requirements, please contact us
- Technical modifications reserved and given values without engagement

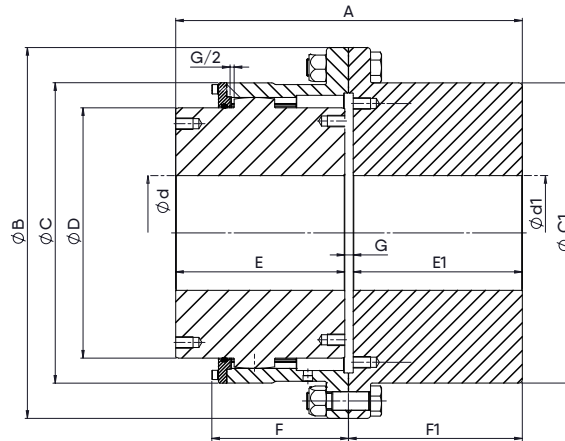

size	torque FFS		torque FSUFS (1)		n max.	Ød min. (2)	Ød max. (3)	Ød1 min. (2)	Ød1 max. (3)	A	ØB	ØC	ØC1	ØD	E	E1	F	F1	G	weight (4)	Inertia J (4)	max. misalignment	
	nominal T <sub>n</sub>	peak T <sub>p</sub>	nominal T <sub>n</sub>	peak T <sub>p</sub>																		angular	axial (±)
FFS FSUFS	kNm	kNm	kNm	kNm	rpm	dimensions mm														kg	kgm <sup>2</sup>	degree	mm
280	244	488	488	976	1900	180	310	180	360	573	591	470	470	394	280	280	226.5	288	13	660	22.5	0.75	10
320	290	580	580	1160	1800	200	340	200	400	599	640	519	518	432	292	292	236	300	14.5	836	34.7	0.75	13
360N	370	740	740	1480	1500	220	375	220	430	625	684	562	562	480	305	305	253	313	14.5	1050	49.7	0.75	13
400N	450	900	900	1800	1400	260	420	260	490	675	742	620	620	530	330	330	272	338	14.5	1300	77.0	0.75	13
450N	560	1120	1120	2240	1300	280	470	280	530	717	804	682	682	594	350	350	286	360	16	1670	117	0.75	13

- (1) Uprated torque execution
- (2) Min. finish machine bore diameter
- (3) Max. bore diameter with one keyway acc. DIN 6885/1
- (4) For pre-bored/unbored hubs

- Couplings can be supplied with several options (e.g. end cap, puller holes, set screws, exposed inch, ATEX, Viton O-Ring, surface protection) → refer to page 48 et seqq. (B403a et seqq.)
- For the correct coupling selection please refer to page 14 et seqq. (A150)
- For special executions or requirements, please contact us
- Technical modifications reserved and given values without engagement

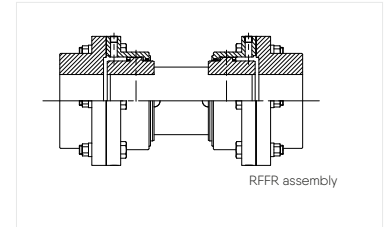
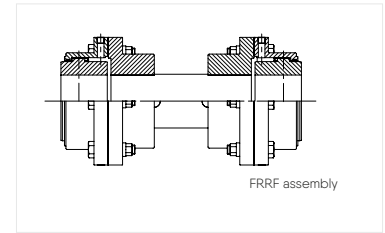
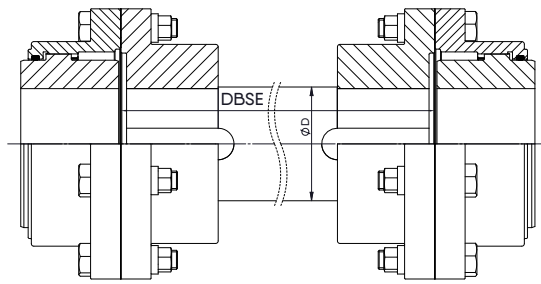

Size	ØD (1)	Max. speed function DBSE								
		600	800	1 000	1 500	2 000	3 000	4 000	5 000	6 000
FFS FSUFS	dimensions mm									
45	47	7 000	7 000	5 118	2 145	1 172	500			
60	62	6 200	6 200	6 200	2 878	1 566	674			
75	74	5 650	5 650	5 650	3 555	1 917	818			
95	93	5 100	5 100	5 100	4 600	2 461	1 042	572		
110	109	4 700	4 700	4 700	4 700	2 967	1 244	680		
130	121	4 350	4 350	4 350	4 350	3 412	1 412	767		
155	137	4 000	4 000	4 000	4 000	3 959	1 624	879	550	
175	153	3 800	3 800	3 800	3 800	3 800	1 846	994	620	
195	171	3 600	3 600	3 600	3 600	3 600	2 096	1 124	700	
215	189	3 450	3 450	3 450	3 450	3 450	2 386	1 270	786	535
240	210	3 300	3 300	3 300	3 300	3 300	2 703	1 431	884	599
275	240	3 050	3 050	3 050	3 050	3 050	3 050	1 669	1 026	694

(1) Diameter D, based on double keyway transmissions, can be adapted depending on application data.

- Couplings can be supplied with several options (e.g. end cap, puller holes, set screws, exposed inch, ATEX, Viton O-Ring, surface protection) → refer to page 48 et seqq. (B403a et seqq.)
- For the correct coupling selection please refer to page 14 et seqq. (A150)
- For special executions or requirements, please contact us
- Technical modifications reserved and given values without engagement

Notes:

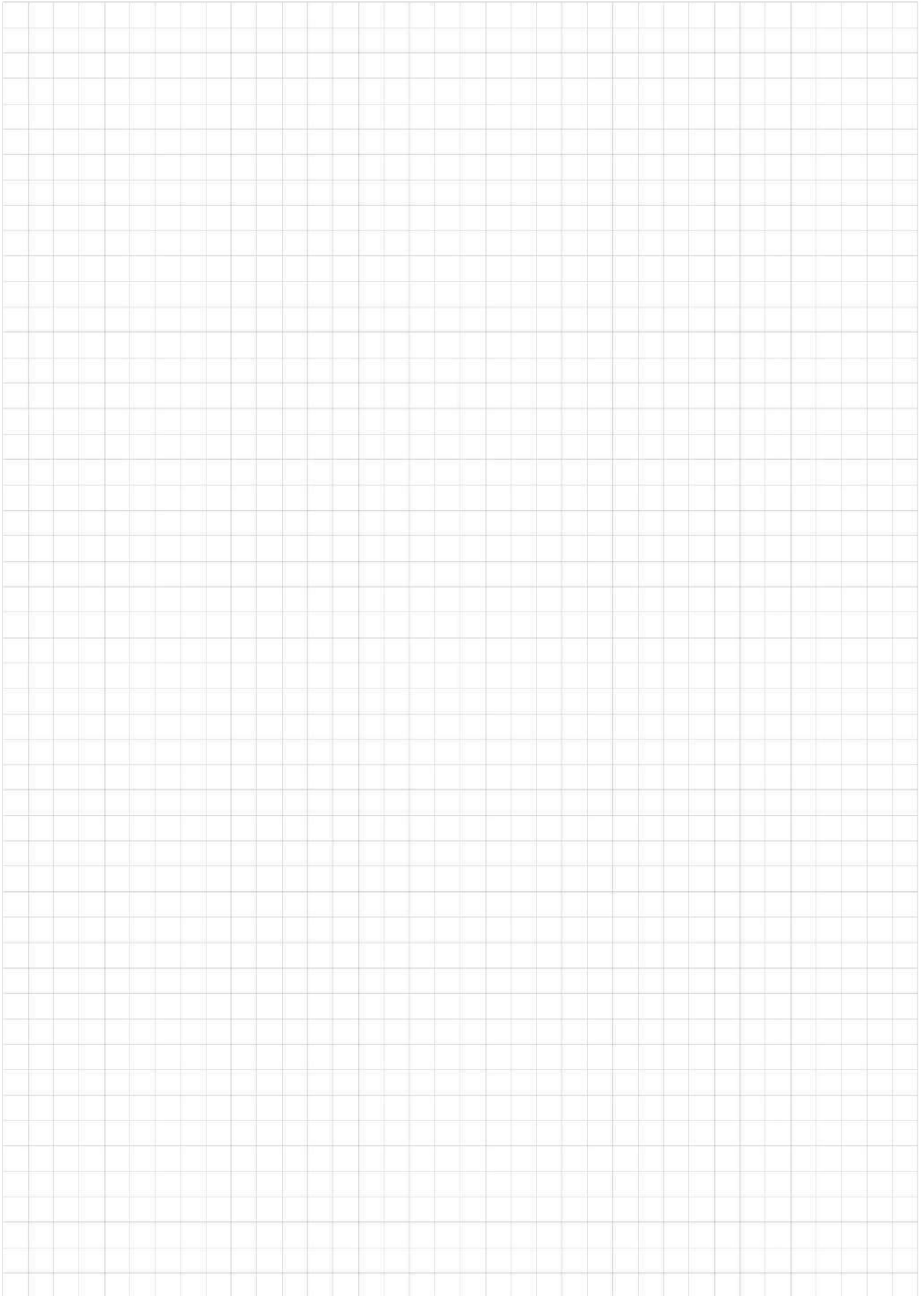

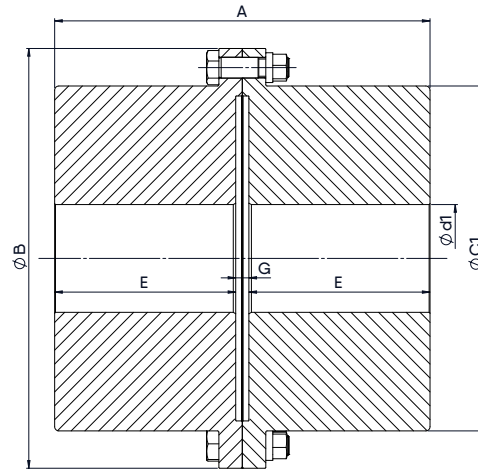

size	torque FRR		torque FSURR (1)		n max.	Ød1 min. (2)	Ød1 max. (3)	A	ØB	ØC1	E	G	weight (4)	Inertia J (4)
	nominal T <sub>n</sub>	peak T <sub>p</sub>	nominal T <sub>n</sub>	peak T <sub>p</sub>										
FRR FSURR	kNm	kNm	kNm	kNm	rpm	dimensions mm						kg	kgm <sup>2</sup>	
45	1.3	2.6	2.6	5.2	7 000	0	55	87	111	80	40	7	4.5	0.006
60	2.8	5.6	5.6	11.2	6 200	0	75	101	141	104	47	7	8.6	0.018
75	5	10	10	20	5 650	0	95	123	171	126	58	7	14.9	0.042
95	10	20	20	40	5 100	0	110	155	210	152	74	7	27.5	0.115
110	16	32	32	64	4 700	0	130	181	234	178	87	7	40.4	0.212
130	22	44	44	88	4 350	52	155	209	274	208	101	7	62	0.479
155	32	64	64	128	4 000	62	180	233	312	245	113	7	90	0.887
175	45	90	90	180	3 800	72	200	266	337	270	129	8	120	1.42
195	62	124	124	248	3 600	82	230	308	380	307	150	8	185	2.70
215	84	168	168	336	3 450	92	250	358	405	338	175	8	244	4.10
240	115	230	230	460	3 300	102	280	392	444	368	190	12	308	6.00
275	174	348	348	696	3 050	132	330	456	506	426	220	16	431	12

- (1) Up-rated torque execution
- (2) Min. finish machine bore diameter (size ≥ 130)
- (3) Max. bore diameter with one keyway acc. DIN 6885/1
- (4) For pre-bored/unbored hubs

- Couplings can be supplied with several options (e.g. end cap, puller holes, set screws, exposed inch, ATEX, Viton O-Ring, surface protection) → refer to page 48 et seqq. (B403a et seqq.)
- For the correct coupling selection please refer to page 14 et seqq. (A150a)
- For special executions or requirements, please contact us
- Technical modifications reserved and given values without engagement

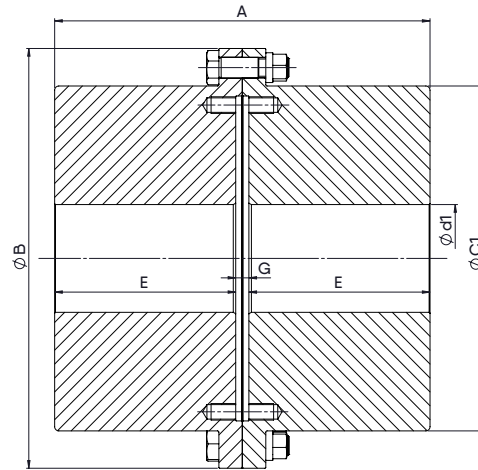

size	torque FRR		torque FSURR (1)		n max.	Ød1 min. (2)	Ød1 max. (3)	A	ØB	ØC1	E	G	weight (4)	Inertia J (4)
	nominal T <sub>n</sub>	peak T <sub>p</sub>	nominal T <sub>n</sub>	peak T <sub>p</sub>										
FRR FSURR	kNm	kNm	kNm	kNm	rpm	dimensions mm						kg	kgm <sup>2</sup>	
280	244	488	488	976	1900	180	360	576	591	470	280	16	712	25
320	290	580	580	1160	1800	200	400	600	640	518	292	16	907	39
360N	370	740	740	1480	1500	220	440	626	684	562	305	16	1089	54
400N	450	900	900	1800	1400	260	490	676	742	620	330	16	1410	85
450N	560	1120	1120	2240	1300	280	530	720	804	676	350	20	1779	128

- (1) Uprated torque execution
- (2) Min. finish machine bore diameter
- (3) Max. bore diameter with one keyway acc. DIN 6885/1
- (4) For pre-bored/unbored hubs

- Couplings can be supplied with several options (e.g. end cap, puller holes, set screws, exposed inch, ATEX, Viton O-Ring, surface protection) → refer to page 48 et seqq. (B403a et seqq.)
- For the correct coupling selection please refer to page 14 et seqq. (A150a)
- For special executions or requirements, please contact us
- Technical modifications reserved and given values without engagement

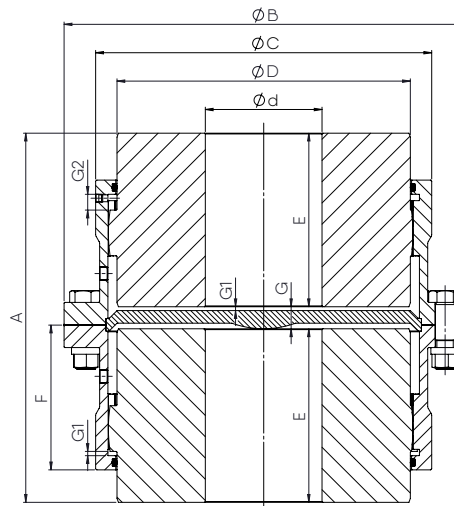

size	torque FSV		torque FSUSV (1)		n max.	Ød min. (2)	Ød max. (3)	A	ØB	ØC	ØD	E	F	G	G1	G2	weight (4)	Inertia J (4)	max. misalignment		
	nominal T <sub>n</sub>	peak T <sub>p</sub>	nominal T <sub>n</sub>	peak T <sub>p</sub>															angular	radial	axial (±)
FSV FSUSV	kNm	kNm	kNm	kNm	rpm	dimensions mm											kg	kgm <sup>2</sup>	degree	mm	mm
45	1.3	2.6	2.6	5.2	5 000	0	50	94	111	80	67	43	41	8	1.5	5.5	4.2	0.005	2x0.75	0.7	1.5
60	2.8	5.6	5.6	11	4 400	0	64	105	141	104	87	50	47	5	1.5	5.5	8.4	0.016	2x0.75	0.7	1.5
75	5.0	10	10	20	4 000	0	78	137	171	130	106	62	58.5	12.5	1.5	6.0	15	0.042	2x0.75	1.0	1.5
95	10	20	20	40	3 600	0	98	163	210	156	130	76	68.5	11	2.5	8.5	27	0.110	2x0.75	1.1	2.5
110	16	32	32	64	3 350	0	112	193	234	181	151	90	82	13	2.5	8.5	40	0.204	2x0.75	1.4	2.5
130	22	44	44	88	3 100	55	132	224	274	209	178	105	98	14	3	12	61	0.451	2x0.75	1.6	3
155	32	64	64	128	2 800	65	158	255	312	247	213	120	109	15	3	12	92	0.869	2x0.75	1.8	3
175	45	90	90	180	2 700	80	175	287	337	273	235	135	121	17	4	16	120	1.38	2x0.75	2.0	4
195	62	124	124	248	2 550	90	198	320	380	307	263	150	132	20	4	16	171	2.47	2x0.75	2.2	4
215	84	168	168	336	2 450	100	217	377	405	338	286	175	152	27	4	16	230	3.78	2x0.75	1.8	4
240	115	230	230	460	2 300	120	244	414	444	368	316	190	165	34	4	16	286	5.52	2x0.75	2.0	4
275	174	348	348	696	2 150	150	290	474	506	426	372	220	184	34	5	14	427	10.9	2x0.75	2.1	5

- (1) Uprated torque execution
- (2) Min. finish machine bore diameter (size ≥ 130)
- (3) Max. bore diameter with one keyway acc. DIN 6885/1
- (4) For pre-bored/unbored hubs

- Couplings can be supplied with several options (e.g. end cap, puller holes, set screws, exposed inch, ATEX, Viton O-Ring, surface protection) → refer to page 48 et seqq. (B403a et seqq.)
- For the correct coupling selection please refer to page 14 et seqq. (A150a)
- For special executions or requirements, please contact us
- Technical modifications reserved and given values without engagement

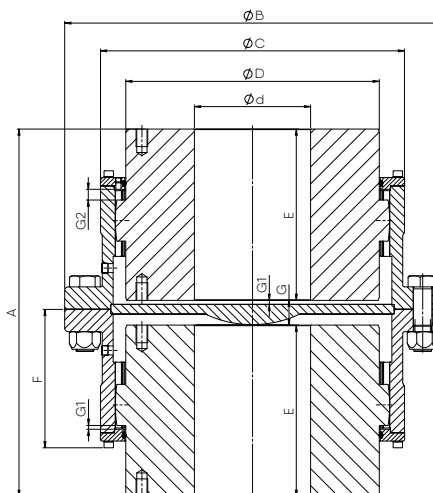

size	torque FSV		torque FSUSV (1)		n max.	Ød min. (2)	Ød max. (3)	A	ØB	ØC	ØD	E	F	G	G1	G2	weight (4)	Inertia J (4)	max. misalignment		
	nominal T <sub>n</sub>	peak T <sub>p</sub>	nominal T <sub>n</sub>	peak T <sub>p</sub>															angular	radial	axial (±)
FSV FSUSV	kNm	kNm	kNm	kNm	rpm			dimensions mm									kg	kgm <sup>2</sup>	degree	mm	mm
280	244	488	488	976	1900	180	310	595	591	472	394	280	226.5	35	7	20.3	610	21.0	2x0.75	4.0	10
320	290	580	580	1160	1800	200	340	690	640	518	432	292	236	35	7	25.4	780	31.0	2x0.75	4.4	13
360N	370	740	740	1480	1500	220	375	645	684	562	480	305	253	35	7	19.5	961	46.0	2x0.75	4.6	13
400N	450	900	900	1800	1400	260	420	700	742	620	530	330	272	40	7	20	1215	82.0	2x0.75	5.0	13
450N	560	1120	1120	2240	1300	280	470	748	804	682	594	350	286	48	7	20	1578	110.0	2x0.75	5.4	13

- (1) Uprated torque execution
- (2) Min. finish machine bore diameter
- (3) Max. bore diameter with one keyway acc. DIN 6885/1
- (4) For pre-bored/unbored hubs

- Couplings can be supplied with several options (e.g. end cap, puller holes, set screws, exposed inch, ATEX, Viton O-Ring, surface protection) → refer to page 48 et seqq. (B403a et seqq.)
- For the correct coupling selection please refer to page 14 et seqq. (A150a)
- For special executions or requirements, please contact us
- Technical modifications reserved and given values without engagement

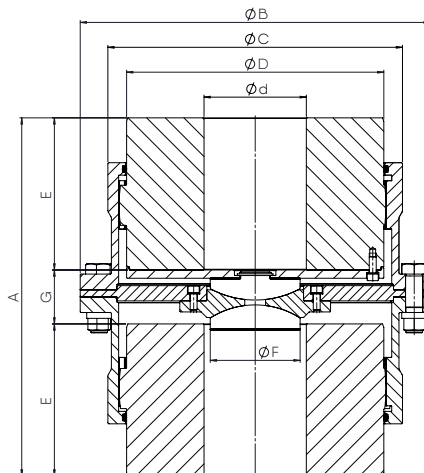
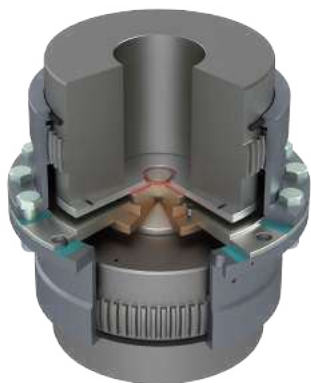

size	torque FSVA		torque FSUVA (1)		n max.	Ød min. (2)	Ød max. (3)	A	ØB	ØC	ØD	E	F	G	weight (4)	Inertia J (4)	max. misalignment		
	nominal T <sub>n</sub>	peak T <sub>p</sub>	nominal T <sub>n</sub>	peak T <sub>p</sub>													angular	radial	axial (±)
FSVA FSUVA	kNm	kNm	kNm	kNm	rpm	dimensions mm									kg	kgm <sup>2</sup>	degree	mm	mm
45	1.3	2.6	2.6	5.2	5 000	0	50	114	111	80	67	43	41	28	4.5	0.005	2x0.75	0.7	3.0
60	2.8	5.6	5.6	11	4 400	0	64	132	141	103.5	87	50	47	32	8.7	0.015	2x0.75	0.8	3.0
75	5.0	10	10	20	4 000	0	78	162	171	129.5	106	62	59	38	15	0.042	2x0.75	1.0	3.0
95	10	20	20	40	3 600	0	98	192	210	156	130	76	65.5	40	28	0.111	2x0.75	1.2	5.0
110	16	32	32	64	3 350	0	112	220	234	181	151	90	82	40	41	0.203	2x0.75	1.4	5.0
130	22	44	44	88	3 100	55	132	256	274	209	178	105	98	46	73	0.526	2x0.75	1.7	6.0
155	32	64	64	128	2 800	65	158	288	312	247	213	120	108.5	48	96	0.883	2x0.75	2.0	6.0
175	45	90	90	180	2 700	80	175	326	337	273	235	135	121	56	123	1.35	2x0.75	2.2	8.0
195	62	124	124	248	2 550	90	198	360	380	307	263	150	132	60	177	2.54	2x0.75	2.4	8.0
215	84	168	168	336	2 450	100	217	424	405	338	286	175	151.5	74	236	3.84	2x0.75	1.9	8.0
240	115	230	230	460	2 300	120	244	464	444	368	316	190	165	84	293	5.56	2x0.75	2.1	8.0
275	174	348	348	696	2 150	150	290	518	506	426	372	220	183.5	78	457	15.5	2x0.75	2.3	10

- (1) Up-rated torque execution
- (2) Min. finish machine bore diameter (size ≥ 130)
- (3) Max. bore diameter with one keyway acc. DIN 6885/1
- (4) For pre-bored/unbored hubs

- Couplings can be supplied with several options (e.g. end cap, puller holes, set screws, exposed inch, ATEX, Viton O-Ring, surface protection) → refer to page 48 et seqq. (B403a et seqq.)
- For the correct coupling selection please refer to page 14 et seqq. (A150a)
- For special executions or requirements, please contact us
- Technical modifications reserved and given values without engagement

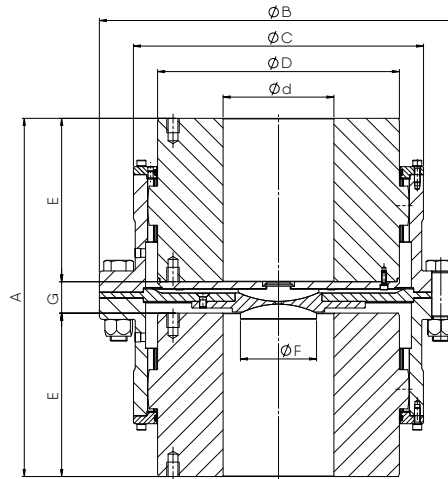
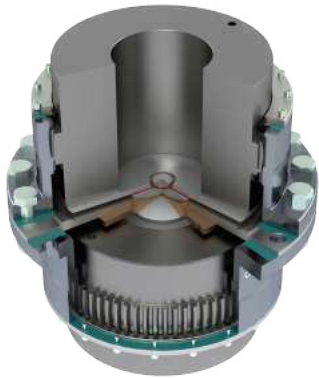

size	torque FSVA		torque FSUVA (1)		n max.	Ød min. (2)	Ød max. (3)	A	ØB	ØC	ØD	E	ØF	G	weight (4)	Inertia J (4)	max. misalignment		
	nominal T <sub>n</sub>	peak T <sub>p</sub>	nominal T <sub>n</sub>	peak T <sub>p</sub>													angular	radial	axial (±)
FSVA FSUVA	kNm	kNm	kNm	kNm	rpm	dimensions mm									kg	kgm <sup>2</sup>	degree	mm	mm
280	244	488	488	976	1900	180	310	613	591	472	394	280	227	53	635	21.0	2x0.75	4.1	10
320	290	580	580	1160	1800	200	340	640	640	518	432	292	236	56	785	32.0	2x0.75	4.3	13
360N	370	740	740	1480	1500	220	375	693	684	562	480	305	253	83	1021	64.6	2x0.75	4.6	13
400N	450	900	900	1800	1400	260	420	752	742	620	530	330	272	92	1267	86.3	2x0.75	5.0	13
450N	560	1120	1120	2240	1300	280	470	809	804	682	594	350	286	109	1616	129	2x0.75	5.4	13

- (1) Up-rated torque execution
- (2) Min. finish machine bore diameter
- (3) Max. bore diameter with one keyway acc. DIN 6885/1
- (4) For pre-bored/unbored hubs

- Couplings can be supplied with several options (e.g. end cap, puller holes, set screws, exposed inch, ATEX, Viton O-Ring, surface protection) → refer to page 48 et seqq. (B403a et seqq.)
- For the correct coupling selection please refer to page 14 et seqq. (A150a)
- For special executions or requirements, please contact us
- Technical modifications reserved and given values without engagement

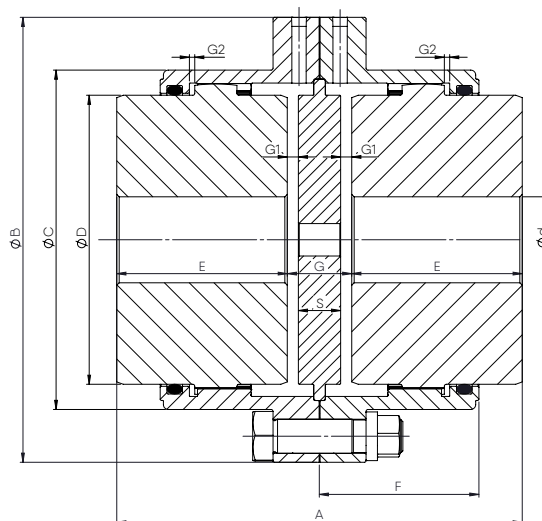

size	torque FST-SHSD		torque FSU-SHSD (1)		n1 max.	n2 max. (2)	Ød min. (3)	Ød max. (4)	A	ØB	ØC	ØD	E	F	G	G1	G2	S	weight (5)	Inertia J (5)	max. misalignment			
	nominal Tn	peak Tp	nominal Tn	peak Tp																	angular	radial	axial (±)	
FST-SHSD FSU-SHSD	kNm	kNm	kNm	kNm	rpm	rpm	dimensions mm													kg	kgm²	degree	mm	mm
45	1.3	2.6	2.6	5.2	5 000	7 000	0	50	107	111	80	67	43	41	21	6	1.5	9	4.4	0.005	2x0.75	0.7	6.0	
60	2.8	5.6	5.6	11	4 400	6 200	0	64	115	141	103.5	87	50	47	15	6	1.5	3	8.3	0.016	2x0.75	0.8	6.0	
75	5.0	10	10	20	4 000	5 650	0	78	155	171	129.5	106	62	58.5	31	6	1.5	19	16	0.042	2x0.75	1.0	6.0	
95	10	20	20	40	3 600	5 100	0	98	181	210	156	130	76	68.5	29	10	2.5	9	27	0.108	2x0.75	1.2	10	
110	16	32	32	64	3 350	4 700	0	112	213	234	181	151	90	82	33	10	2.5	13	41	0.198	2x0.75	1.4	10	
130	22	44	44	88	3 100	4 350	55	132	250	274	209	178	105	98	40	12	3	16	63	0.445	2x0.75	1.6	12	
155	32	64	64	128	2 800	4 000	65	158	282	312	247	213	120	108.5	42	12	3	18	95	0.876	2x0.75	1.8	12	
175	45	90	90	180	2 700	3 800	80	175	320	337	273	235	135	121	50	16	4	18	124	1.37	2x0.75	2.0	16	
195	62	124	124	248	2 550	3 600	90	198	356	380	307	263	150	132	56	16	4	24	178	2.55	2x0.75	2.4	16	
215	84	168	168	336	2 450	3 450	100	217	420	405	338	286	175	151.5	70	16	4	38	242	3.93	2x0.75	2.8	16	
240	115	230	230	460	2 300	3 300	120	244	464	444	368	316	190	165	84	16	4	52	308	5.82	2x0.75	3.0	16	
275	174	348	348	696	2 150	3 050	150	290	516	506	426	372	220	183.5	76	20	5	36	446	11.5	2x0.75	3.4	20	

- (1) Uprated torque execution
- (2) Special balancing recommended and use of high speed grease
- (3) Min. finish machine bore diameter (size ≥ 130)
- (4) Max. bore diameter with one keyway acc. DIN 6885/1
- (5) For pre-bored/unbored hubs

- Couplings can be supplied with several options (e.g. end cap, puller holes, set screws, exposed inch, ATEX, Viton O-Ring, surface protection) → refer to page 48 et seqq. (B403a et seqq.)
- For the correct coupling selection please refer to page 14 et seqq. (A150a)
- For special executions or requirements, please contact us
- Technical modifications reserved and given values without engagement

# FST-SHLD/FSU-SHLD STANDARD HUB LARGE DBSE

45 ▶ 275

C4255a

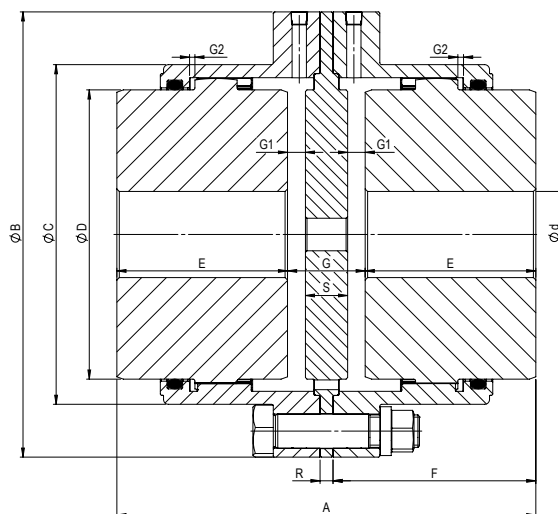

size	torque FST-SHLD		torque FSU-SHLD (1)		n1 max.	n2 max. (2)	Ød min. (3)	Ød max. (4)	A	ØB	ØC	ØD	E	F	G	G1	G2	R	S	weight (5)	Inertia J (5)	max. misalignment		
	nominal Tn	peak Tp	nominal Tn	peak Tp																		angular	radial	axial (±)
FST-SHLD FSU-SHLD	kNm	kNm	kNm	kNm	rpm	rpm	dimensions mm													kg	kgm²	degree	mm	mm
45	1.3	2.6	2.6	5.2	5 000	7 000	0	50	107	111	80	67	43	41	21	6	1.5	0	9	5.0	0.005	2x0.75	0.7	3.0
60	2.8	5.6	5.6	11	4 400	6 200	0	64	115	141	103.5	87	50	47	15	6	1.5	0	3	8.5	0.018	2x0.75	0.8	3.0
75	5.0	10	10	20	4 000	5 650	0	78	155	171	129.5	106	62	58.5	31	6	1.5	0	19	15	0.047	2x0.75	1.0	3.0
95	10	20	20	40	3 600	5 100	0	98	181	210	156	130	76	68.5	29	10	2.5	0	9	27	0.121	2x0.75	1.2	5.0
110	16	32	32	64	3 350	4 700	0	112	221	234	181	151	90	82	41	10	2.5	8	21	44	0.217	2x0.75	1.4	5.0
130	22	44	44	88	3 100	4 350	55	132	258	274	209	178	105	98	48	12	3	8	24	66	0.480	2x0.75	1.6	6.0
155	32	64	64	128	2 800	4 000	65	158	297	312	247	213	120	108.5	57	12	3	15	33	104	0.985	2x0.75	1.8	6.0
175	45	90	90	180	2 700	3 800	80	175	335	337	273	235	135	121	65	16	4	15	33	135	1.52	2x0.75	2.0	8.0
195	62	124	124	248	2 550	3 600	90	198	392	380	307	263	150	132	92	16	4	36	60	210	3.13	2x0.75	2.4	8.0
215	84	168	168	336	2 450	3 450	100	217	448	405	338	286	175	152	98	16	4	28	66	271	4.51	2x0.75	2.8	8.0
240	115	230	230	460	2 300	3 300	120	244	491	444	368	316	190	165	111	16	4	27	79	341	6.63	2x0.75	3.0	8.0
275	174	348	348	696	2 150	3 050	150	290	546	506	426	372	220	184	106	20	5	30	66	412	11.2	2x0.75	3.4	10

- (1) Uprated torque execution
- (2) Special balancing recommended and use of high speed grease
- (3) Min. finish machine bore diameter (size ≥ 130)
- (4) Max. bore diameter with one keyway acc. DIN 6885/1
- (5) For pre-bored/unbored hubs

- Couplings can be supplied with several options (e.g. end cap, puller holes, set screws, exposed inch, ATEX, Viton O-Ring, surface protection) → refer to page 48 et seqq. (B403a et seqq.)
- For the correct coupling selection please refer to page 14 et seqq. (A150a)
- For special executions or requirements, please contact us
- Technical modifications reserved and given values without engagement

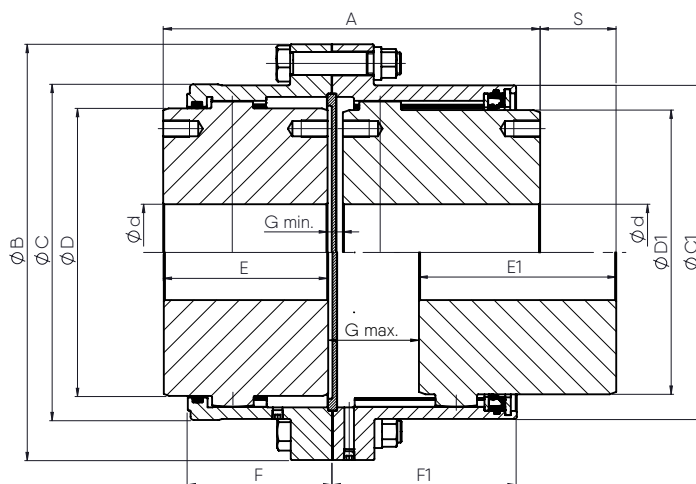
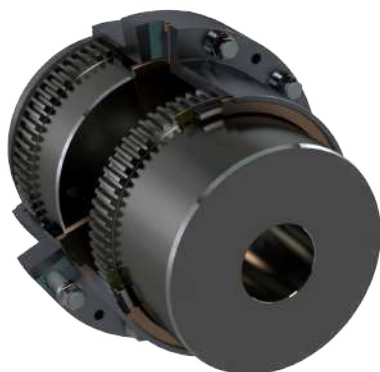

size	torque FSH		torque FSUSH (1)		n max.	Ød min. (2)	Ød max. (3)	Ød1 min. (2)	Ød1 max. (3)	A	ØB	ØC	ØD	ØD1	E	E1	F	F1	G min.	G max.	S (travel) (4)	weight (5)	Inertia J (5)	max. misalignment	
	nominal T <sub>n</sub>	peak T <sub>p</sub>	nominal T <sub>n</sub>	peak T <sub>p</sub>																				angular	axial (±)
FSH FSUSH	kNm	kNm	kNm	kNm	rpm	dimensions mm																kg	kgm²	degree	mm
45	1.3	2.6	2.6	5.0	5 000	0	50	0	42	181	111	80	67	60	43	130	41	130	8	85	77	4.3	0.005	2x0.5	3.0
60	2.8	5.6	5.6	11	4 400	0	64	0	55	193	141	103.5	87	78	50	135	47	138	8	93	85	12	0.021	2x0.5	3.0
75	5.0	10	10	20	4 000	0	78	0	70	210	171	129.5	106	98	62	140	58.5	139	8	88	80	21	0.053	2x0.5	3.0
95	10	20	20	40	3 600	0	98	0	85	231	210	156	130	115	76	145	68.5	144	10	90	80	34	0.129	2x0.5	5.0
110	16	32	32	64	3 350	0	112	0	100	250	234	181	151	140	90	150	82	157	10	100	90	49	0.234	2x0.5	5.0
130	22	44	44	88	3 100	55	132	55	120	276	274	209	178	165	105	160	98	159	11	96	85	71	0.501	2x0.5	6.0
155	32	64	64	128	2 800	65	158	65	140	291	312	247	213	195	120	160	108.5	162	11	91	80	100	0.925	2x0.5	6.0
175	45	90	90	180	2 700	80	175	80	170	319	337	273	235	230	135	170	121	168	14	89	75	130	1.45	2x0.5	8.0
195	62	124	124	248	2 550	90	198	90	190	344	380	307	263	260	150	180	132	168	14	84	70	182	1.62	2x0.5	8.0
215	84	168	168	336	2 450	100	217	100	210	381	405	338	286	280	175	190	151.5	179	16	86	70	232	3.82	2x0.5	8.0
240	115	230	230	460	2 300	118	244	118	228	406	444	368	316	300	190	200	165	190	16	97	81	298	5.82	2x0.5	8.0
275	174	348	348	696	2 150	148	290	148	258	458	506	426	372	340	220	220	184	200	18	105	87	444	11	2x0.5	10

- (1) Up-rated torque execution
- (2) Min. finish machine bore diameter (size ≥ 130)
- (3) Max. bore diameter with one keyway acc. DIN 6885/1
- (4) Different travel lengths available on request
- (5) For pre-bored/unbored hubs

- Couplings can be supplied with several options (e.g. end cap, puller holes, set screws, exposed inch, ATEX, Viton O-Ring, surface protection) → refer to page 48 et seqq. (B403a et seqq.)
- For the correct coupling selection please refer to page 14 et seqq. (A150a)
- For special executions or requirements, please contact us
- Technical modifications reserved and given values without engagement

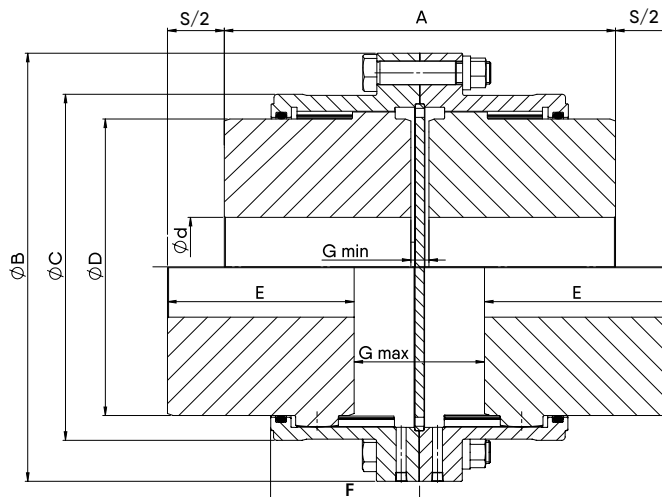

size	torque FDSH		torque FSUDSH (1)		n max.	Ød min. (2)	Ød max. (3)	A	ØB	ØC	ØD	E	F	G min.	G max.	S max. (travel)	weight (4)	Inertia J (4)	max. misalignment				
	nominal T <sub>n</sub>	peak T <sub>p</sub>	nominal T <sub>n</sub>	peak T <sub>p</sub>															angular	radial		axial (±)	
FDSH FSUDSH	kNm	kNm	kNm	kNm	rpm	dimensions mm												kg	kgm <sup>2</sup>	degree	@ G min.	@ G max.	mm
45	1.3	2.6	2.6	5.2	5 000	0	50	145	111	80	67	67.5	41	10	28	18	5.7	0.006	2x0.75	0.5	0.7	3.0	
60	2.8	5.6	5.6	11	4 400	0	64	213	141	103.5	87	101.5	47	10	28	18	13	0.021	2x0.75	0.5	0.8	3.0	
75	5.0	10	10	20	4 000	0	78	233	171	129.5	106	111.5	58.5	10	40	30	22	0.051	2x0.75	0.6	1.0	3.0	
95	10	20	20	40	3 600	0	98	250	210	156	130	119	68.9	12	59	47	36	0.127	2x0.75	0.6	1.2	5.0	
110	16	32	32	64	3 350	0	112	283	234	181	151	135.5	82	12	64	52	53	0.234	2x0.75	0.7	1.4	5.0	
130	22	44	44	88	3 100	55	132	292	274	209	178	139.5	98	13	67	54	73	0.494	2x0.75	1.0	1.7	6.0	
155	32	64	64	128	2 800	65	158	320	312	247	213	153.5	108.5	13	79	66	109	0.970	2x0.75	1.0	1.9	6.0	
175	45	90	90	180	2 700	80	175	322	337	273	235	153	121	16	102	86	132	1.42	2x0.75	1.0	2.1	8.0	
195	62	124	124	248	2 550	90	198	348	380	307	263	166	132	16	116	100	184	2.58	2x0.75	1.1	2.4	8.0	
215	84	168	168	336	2 450	100	217	404	405	338	286	194	151.5	16	120	104	245	3.95	2x0.75	1.4	2.8	8.0	
240	115	230	230	460	2 300	120	244	452	444	368	316	216	165	20	136	116	312	5.89	2x0.75	1.5	3.0	8.0	
275	174	348	348	696	2 150	150	290	572	506	426	372	275	184	22	160	138	402	8.48	2x0.75	1.5	3.2	10	

- (1) Uprated torque execution
- (2) Min. finish machine bore diameter (size ≥ 130)
- (3) Max. bore diameter with one keyway acc. DIN 6885/1
- (4) For pre-bored/unbored hubs

- Couplings can be supplied with several options (e.g. end cap, puller holes, set screws, exposed inch, ATEX, Viton O-Ring, surface protection) → refer to page 48 et seqq. (B403a et seqq.)
- For the correct coupling selection please refer to page 14 et seqq. (A150a)
- For special executions or requirements, please contact us
- Technical modifications reserved and given values without engagement

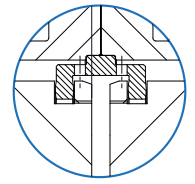
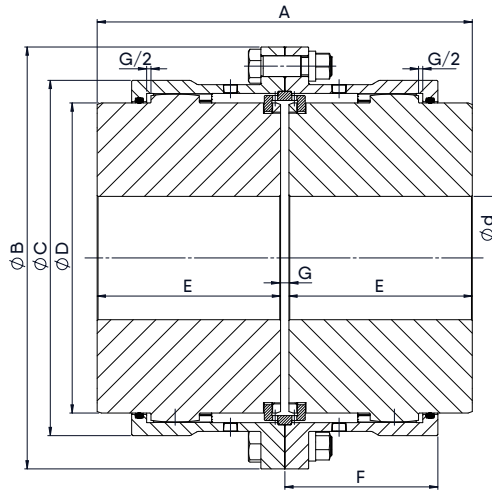

End float limitation  
 needs to be specified

size	torque FLE		torque FSULE (1)		n1 max.	n2 max. (2)	Ød min. (3)	Ød max. (4)	A	ØB	ØC	ØD	E	F	G	weight (5)	Inertia J (5)	max. misalignment	
	nominal T <sub>n</sub>	peak T <sub>p</sub>	nominal T <sub>n</sub>	peak T <sub>p</sub>														angular	radial
FLE FSULE	kNm	kNm	kNm	kNm	rpm	rpm	dimensions mm								kg	kgm <sup>2</sup>	degree	mm	
45	1.3	2.6	2.6	5.2	5 000	7 000	0	50	89	111	80	67	43	41	3	4.1	0.005	2x0.75	0.7
60	2.8	5.6	5.6	11	4 400	6 200	0	64	103	141	104	87	50	47	3	8.0	0.015	2x0.75	0.8
75	5.0	10	10	20	4 000	5 650	0	78	127	171	130	106	62	58.5	3	15	0.041	2x0.75	1.0
95	10	20	20	40	3 600	5 100	0	98	157	210	156	130	76	68.5	5	26	0.109	2x0.75	1.2
110	16	32	32	64	3 350	4 700	0	112	185	234	181	151	90	82	5	39	0.191	2x0.75	1.4
130	22	44	44	88	3 100	4 350	55	132	216	274	209	178	105	98	6	60	0.436	2x0.75	1.6
155	32	64	64	128	2 800	4 000	65	158	246	312	247	213	120	108.5	6	90	0.854	2x0.75	1.8
175	45	90	90	180	2 700	3 800	80	175	278	337	273	235	135	121	8	115	1.32	2x0.75	2.0
195	62	124	124	248	2 550	3 600	90	198	308	380	307	263	150	132	8	166	2.43	2x0.75	2.4
215	84	168	168	336	2 450	3 450	100	217	358	405	338	286	175	151.5	8	219	3.69	2x0.75	2.8
240	115	230	230	460	2 300	3 300	120	244	388	444	368	316	190	165	8	275	5.37	2x0.75	3.0
275	174	348	348	696	2 150	3 050	150	290	450	506	426	372	220	183.5	10	411	11	2x0.75	3.4

- (1) Uprated torque execution
- (2) Special balancing recommended and use of high speed grease
- (3) Min. finish machine bore diameter (size ≥ 130)
- (4) Max. bore diameter with one keyway acc. DIN 6885/1
- (5) For pre-bored/unbored hubs

- Couplings can be supplied with several options (e.g. end cap, puller holes, set screws, exposed inch, ATEX, Viton O-Ring, surface protection) → refer to page 48 et seqq. (B403a et seqq.)
- For the correct coupling selection please refer to page 14 et seqq. (A150a)
- For special executions or requirements, please contact us
- Technical modifications reserved and given values without engagement

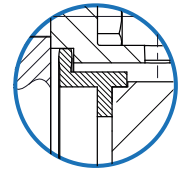
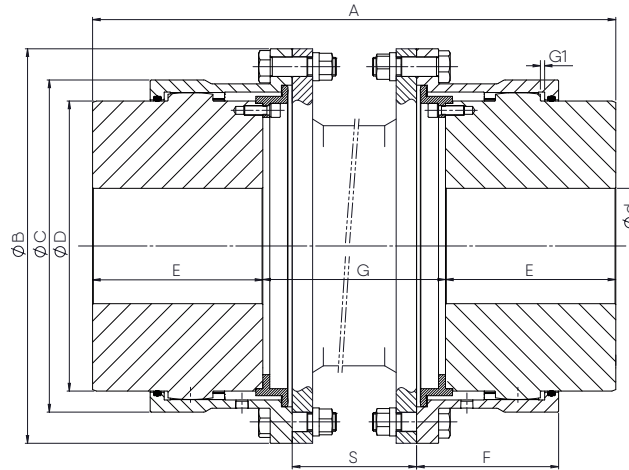
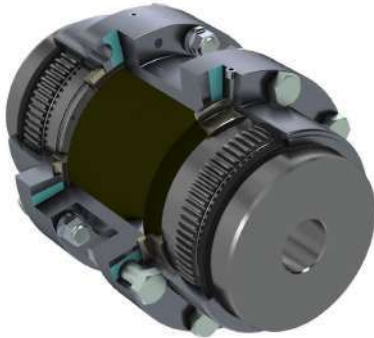

End float limitation  
need to be specified

size	torque FSELE		torque FSUSELE (1)		n1 max. (2)	n2 max. (2/3)	Ød min. (4)	Ød max. (5)	A min.	ØB	ØC	ØD	E	F	G min.	G1	S min.	weight (6)		inertia J (6)		max. misalignment (7)	
	nominal Tn	peak Tp	nominal Tn	peak Tp														@ G min.	per 10 mm G increment	@ G min.	per 10 mm G increment	angular	axial (±)
FSELE FSUSELE	kNm	kNm	kNm	kNm	rpm	rpm	dimensions mm										kg	kgm²		degree	mm		
45	1.3	2.6	2.6	5.2	5 000	7 000	0	50	167	111	80	67	43	41	81	1.5	60	4.4	0.006	0.060	0.001	2X0.75	1.0
60	2.8	5.6	5.6	11	4 400	6 200	0	64	195	141	104	87	50	47	3	1.5	80	13	0.030	0.300	0.001	2X0.75	1.0
75	5.0	10	10	20	4 000	5 650	0	78	245	171	130	106	62	58.5	3	1.5	90	16	0.050	0.160	0.001	2X0.75	1.0
95	10	20	20	40	3 600	5 100	0	98	291	210	156	130	76	68.5	5	2.5	110	40	0.190	0.660	0.003	2X0.75	1.0
110	16	32	32	64	3 350	4 700	0	112	323	234	181	151	90	82	5	2.5	110	42	0.220	0.230	0.002	2X0.75	1.0
130	22	44	44	88	3 100	4 350	55	132	380	274	209	178	105	98	6	3	130	82	0.720	0.720	0.007	2X0.75	1.0
155	32	64	64	128	2 800	4 000	65	158	412	312	247	213	120	108.5	6	3	130	118	1.320	3.13	0.054	2X0.75	1.0
175	45	90	90	180	2 700	3 800	80	175	450	337	273	235	135	121	8	4	130	147	1.920	3.31	0.069	2X0.75	1.0
195	62	124	124	248	2 550	3 600	90	198	516	380	307	263	150	132	8	4	160	215	3.650	1.41	0.029	2X0.75	1.0
215	84	168	168	336	2 450	3 450	100	217	580	405	338	286	175	151.5	8	4	160	275	5.240	4.50	0.138	2X0.75	2.0
240	115	230	230	460	2 300	3 300	120	244	624	444	368	316	190	165	8	4	160	332	7.350	2.82	0.054	2X0.75	2.0
275	174	348	348	696	2 150	3 050	150	290	676	506	426	372	220	183.5	10	5	160	481	13.800	6.68	0.326	2X0.75	2.0

- (1) Up-rated torque execution
- (2) Refer to table below "Max. speed function G"
- (3) Special balancing recommended and use of high speed grease
- (4) Min. finish machine bore diameter (size ≥ 130)
- (5) Max. bore diameter with one keyway acc. DIN 6885/1
- (6) For pre-bored/unbored hubs
- (7) Max. radial misalignment = 0.013 x (G + K)  
Where: G = required DBSE; K = coefficient as below

Size	Max. speed function G							
	G	1 000	1 500	2 000	3 000	4 000	5 000	6 000
45	7 000	4 621	2 549	1 112	619			
60	6 200	5 986	3 279	1 420	788	501		
75	5 650	5 650	3 987	1 726	959	609		
95	5 100	5 100	4 724	2 037	1 129	716		
110	4 700	4 700	4 700	2 505	1 388	880	608	
130	4 350	4 350	4 350	3 020	1 665	1 053	726	
155	4 000	4 000	4 000	3 547	1 956	1 237	852	
175	3 800	3 800	3 800	3 800	2 177	1 377	949	
195	3 600	3 600	3 600	3 600	2 504	1 577	1 084	
215	3 450	3 450	3 450	3 450	2 722	1 715	1 179	
240	3 300	3 300	3 300	3 300	2 901	1 837	1 267	
275	3 050	3 050	3 050	3 050	3 050	2 145	1 478	

K factor for max. radial misalignment
34
44
48
64
76
88
102
114
126
144
152
187

- Couplings can be supplied with several options (e.g. end cap, puller holes, set screws, exposed inch, ATEX, Viton O-Ring, surface protection) → refer to page 48 et seqq. (B403a et seqq.)
- For the correct coupling selection please refer to page 14 et seqq. (A150a)
- For special executions or requirements, please contact us
- Technical modifications reserved and given values without engagement

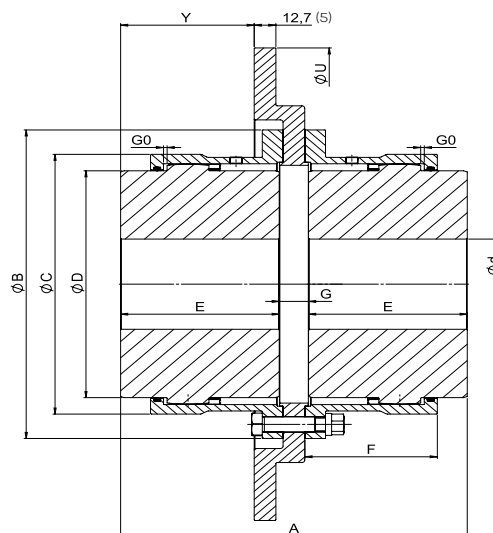
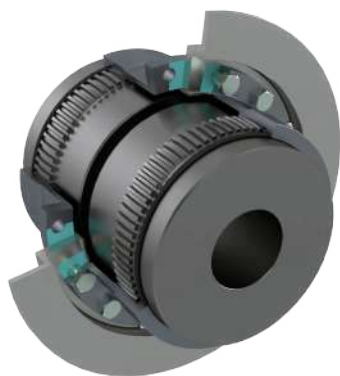

size	torque FBD		torque FSUBD (1)		n1 max.	n2 max. (2)	Ød min. (3)	Ød max. (4)	A	ØB	ØC	ØD	E	F	G0	G	Brake disc		weight (6)	Inertia J (6)	max. misalignment		
	nominal Tn	peak Tp	nominal Tn	peak Tp													ØU	Y			angular	radial	axial (±)
FBD FSUBD	kNm	kNm	kNm	kNm	rpm	rpm	dimension mm										kg	kgm²	degree	mm	mm		
45	1.3	2.6	2.6	5.2	5 000	7 000	0	50	94	111	80	67	43	41	1.5	8.3	250	15.7	8.6	0.043	2x0.75	0.8	3.0
60	2.8	5.6	5.6	11.2	4 400	6 200	0	64	112	141	103.5	87	50	47	1.5	12	305	21.4	16	0.099	2x0.75	0.9	3.0
75	5.0	10	10	20	4 000	5 650	0	78	139	171	129.5	106	62	58.5	1.5	15.2	356	23.6	27	0.232	2x0.75	1.2	3.0
95	10	20	20	40	3 600	5 100	0	98	166	210	156	130	76	68.5	2.5	14	406	35.4	41	0.434	2x0.75	1.3	5.0
110	16	32	32	64	3 350	4 700	0	112	197	234	181	151	90	82	2.5	17.2	457	52.6	60	0.749	2x0.75	1.6	5.0
130	22	44	44	88	3 100	4 350	55	132	228	274	209	178	105	98	3	18.2	514	68.1	85	1.31	2x0.75	1.8	6.0
155	32	64	64	128	2 800	4 000	65	158	258	312	247	213	120	108.5	3	18.2	514	83.1	115	1.04	2x0.75	2.0	6.0
175	45	90	90	180	2 700	3 800	80	175	289	337	273	235	135	121	4	19.2	610	98.6	155	3.22	2x0.75	2.1	8.0
195	62	124	124	248	2 550	3 600	90	198	322	380	307	263	150	132	4	22.3	711	116.7	223	6.17	2x0.75	2.6	8.0
215	84	168	168	336	2 450	3 450	100	217	379	405	338	286	175	151.5	4	28.7	813	148.1	317	11.4	2x0.75	3.1	8.0
240	115	230	230	460	2 300	3 300	120	244	408	444	368	316	190	165	4	27.7	813	162.6	375	13.3	2x0.75	3.3	8.0
275	174	348	348	696	2 150	3 050	150	290	470	506	426	372	220	183.5	5	29.7	914	193.6	534	24.7	2x0.75	3.7	10

Size	Typical brake disc combinations dimensions mm									
	250	305	356	406	457	514	610	711	813	914
45	✓	✓	✓							
60	✓	✓	✓	✓						
75	✓	✓	✓	✓	✓	✓				
95			✓	✓	✓	✓	✓			
110			✓	✓	✓	✓	✓	✓		
130				✓	✓	✓	✓	✓	✓	
155					✓	✓	✓	✓	✓	✓
175						✓	✓	✓	✓	✓
195							✓	✓	✓	✓
215							✓	✓	✓	✓
240								✓	✓	✓
275								✓	✓	✓

- (1) Up-rated torque execution
- (2) Special balancing recommended and use of high speed grease
- (3) Min. finish machine bore diameter (size ≥ 130)
- (4) Max. bore diameter with one keyway acc. DIN 6885/1
- (5) Other brake disc thicknesses available on request
- (6) For pre-bored/unbored hubs

- Couplings can be supplied with several options (e.g. end cap, puller holes, set screws, exposed inch, ATEX, Viton O-Ring, surface protection) → refer to page 48 et seqq. (B403a et seqq.)
- For the correct coupling selection please refer to page 14 et seqq. (A150a)
- For special executions or requirements, please contact us
- Technical modifications reserved and given values without engagement

FBDS/FSUBDS  
BRAKE DISC STRAIGHT

45 ▶ 275

C4263a

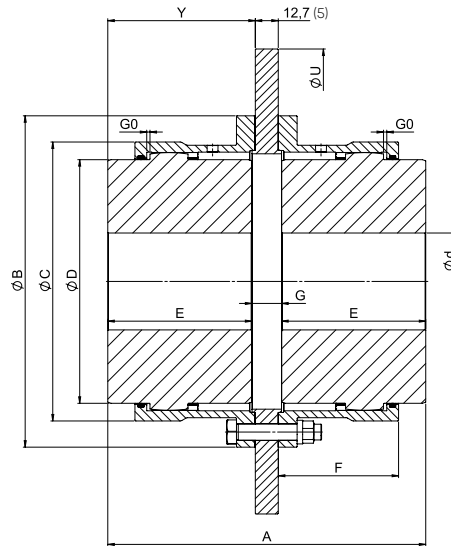
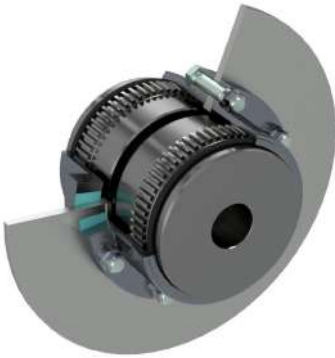

size	torque FBDS		torque FSUBDS (1)		n1 max.	n2 max. (2)	Ød min. (3)	Ød max. (4)	A	ØB	ØC	ØD	E	F	G0	G	Brake disc straight		weight (6)	Inertia J (6)	max. misalignment		
	nominal Tn	peak Tp	nominal Tn	peak Tp													ØU	Y			angular	radial	axial (±)
FBDS FSUBDS	kNm	kNm	kNm	kNm	rpm	rpm	dimension mm										kg	kgm²	degree	mm	mm		
45	1.3	2.6	2.6	5.2	5 000	7 000	0	50	102	111	80	67	43	41	1.5	16	250	44.7	8.6	0.043	2x0.75	0.9	3.0
60	2.8	5.6	5.6	11	4 400	6 200	0	64	116	141	103.5	87	50	47	1.5	16	300	51.7	14	0.048	2x0.75	1.0	3.0
75	5.0	10	10	20	4 000	5 650	0	78	140	171	129.5	106	62	58.5	1.5	16	350	63.7	23	0.192	2x0.75	1.2	3.0
95	10	20	20	40	3 600	5 100	0	98	170	210	156	130	76	68.5	2.5	18	400	78.7	37	0.368	2x0.75	1.4	5.0
110	16	32	32	64	3 350	4 700	0	112	198	234	181	151	90	82	2.5	18	460	92.7	53	0.652	2x0.75	1.6	5.0
130	22	44	44	88	3 100	4 350	55	132	229	274	209	178	105	98	3	19	515	108.2	78	1.15	2x0.75	1.8	6.0
155	32	64	64	128	2 800	4 000	65	158	259	312	247	213	120	108.5	3	19	515	123.2	115	1.61	2x0.75	2.0	6.0
175	45	90	90	180	2 700	3 800	80	175	291	337	273	235	135	121	4	21	610	139.2	151	2.79	2x0.75	2.2	8.0
195	62	124	124	248	2 550	3 600	90	198	321	380	307	263	150	132	4	21	710	154.2	200	5.13	2x0.75	2.6	8.0
215	84	168	168	336	2 450	3 450	100	217	371	405	338	286	175	151.5	4	21	810	179.2	265	8.2	2x0.75	3.0	8.0
240	115	230	230	460	2 300	3 300	120	244	401	444	368	316	190	165	4	21	810	194.2	336	10.2	2x0.75	3.2	8.0
275	174	348	348	696	2 150	3 050	150	290	463	506	426	372	220	183.5	5	23	915	225.2	465	19.4	2x0.75	3.6	10

Size	Typical brake disc combinations dimensions mm										
	200	250	300	350	400	460	515	610	710	810	915
45	✓	✓	✓	✓	✓	✓	✓	✓	✓	✓	✓
60		✓	✓	✓	✓	✓	✓	✓	✓	✓	✓
75		✓	✓	✓	✓	✓	✓	✓	✓	✓	✓
95			✓	✓	✓	✓	✓	✓	✓	✓	✓
110				✓	✓	✓	✓	✓	✓	✓	✓
130					✓	✓	✓	✓	✓	✓	✓
155						✓	✓	✓	✓	✓	✓
175							✓	✓	✓	✓	✓
195								✓	✓	✓	✓
215									✓	✓	✓
240										✓	✓
275											✓

- (1) Uprated torque execution
- (2) Special balancing recommended and use of high speed grease
- (3) Min. finish machine bore diameter (size ≥ 130)
- (4) Max. bore diameter with one keyway acc. DIN 6885/1
- (5) Other brake disc thicknesses available on request
- (6) For pre-bored/unbored hubs

- Couplings can be supplied with several options (e.g. end cap, puller holes, set screws, exposed inch, ATEX, Viton O-Ring, surface protection) → refer to page 48 et seqq. (B403a et seqq.)
- For the correct coupling selection please refer to page 14 et seqq. (A150a)
- For special executions or requirements, please contact us
- Technical modifications reserved and given values without engagement

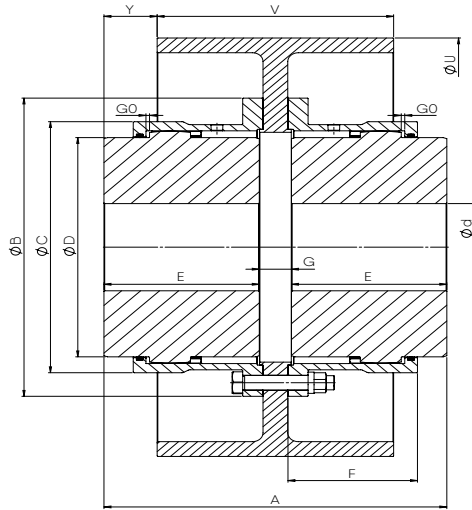

size	torque FBP		torque FSUBP (1)		n1 max.	n2 max. (2)	Ød min. (3)	Ød max. (4)	A	ØB	ØC	ØD	E	F	G0	G	Brake pulley T-Shape			weight (5)	Inertia J (5)	max. misalignment		
	nominal Tn	peak Tp	nominal Tn	peak Tp													ØU	V	Y			angular	radial	axial (±)
FBP FSUBP	kNm	kNm	kNm	kNm	rpm	rpm	dimension mm										kg	kgm²	degree	mm	mm			
45	1.3	2.6	2.6	5.2	5 000	7 000	0	50	99	111	80	67	43	41	1.5	13	200	75	12	9.3	0.045	2x0.75	0.8	3.0
60	2.8	5.6	5.6	11	4 400	6 200	0	64	113	141	103.5	87	50	47	1.5	13	200	75	19	13	0.047	2x0.75	0.9	3.0
75	5.0	10	10	20	4 000	5 650	0	78	137	171	129.5	106	62	58.5	1.5	13	250	95	21	23	0.148	2x0.75	1.1	3.0
95	10	20	20	40	3 600	5 100	0	98	167	210	156	130	76	68.5	2.5	15	250	95	36	34	0.221	2x0.75	1.3	5.0
110	16	32	32	64	3 350	4 700	0	112	197	234	181	151	90	82	2.5	17	315	118	40	52	0.491	2x0.75	1.6	5.0
130	22	44	44	88	3 100	4 350	55	132	231	274	209	178	105	98	3	21	400	150	41	84	1.25	2x0.75	1.8	6.0
155	32	64	64	128	2 800	4 000	65	158	264	312	247	213	120	108.5	3	24	500	190	37	132	3.03	2x0.75	2.0	6.0
175	45	90	90	180	2 700	3 800	80	175	296	337	273	235	135	121	4	26	500	190	53	158	3.53	2x0.75	2.2	8.0
195	62	124	124	248	2 550	3 600	90	198	330	380	307	263	150	132	4	30	630	236	47	242	8.42	2x0.75	2.7	8.0
215	84	168	168	336	2 450	3 450	100	217	380	405	338	286	175	152	4	30	630	236	72	295	9.76	2x0.75	3.1	8.0
240	115	230	230	460	2 300	3 300	120	244	412	444	368	316	190	165	4	32	630	236	88	353	11.9	2x0.75	3.3	8.0
275	174	348	348	696	2 150	3 050	150	290	474	506	426	372	220	184	5	34	710	265	105	505	22.1	2x0.75	3.7	10

- (1) Uprated torque execution
- (2) Special balancing recommended and use of high speed grease
- (3) Min. finish machine bore diameter (size ≥ 130)
- (4) Max. bore diameter with one keyway acc. DIN 6885/1
- (5) For pre-bored/unbored hubs

Typical brake disc combinations							
Size	dimensions mm						
	200	250	315	400	500	630	710
45	✓	✓					
60	✓	✓	✓				
75		✓	✓	✓			
95			✓	✓	✓		
110			✓	✓	✓	✓	
130				✓	✓	✓	✓
155					✓	✓	✓
175					✓	✓	✓
195						✓	✓
215							✓
240							✓
275							✓
Brake pulley	dimensions mm						
	U	200	250	315	400	500	630
V	75	95	118	150	190	236	265

- Couplings can be supplied with several options (e.g. end cap, puller holes, set screws, exposed inch, ATEX, Viton O-Ring, surface protection) → refer to page 48 et seqq. (B403a et seqq.)
- For the correct coupling selection please refer to page 14 et seqq. (A150a)
- For special executions or requirements, please contact us
- Technical modifications reserved and given values without engagement

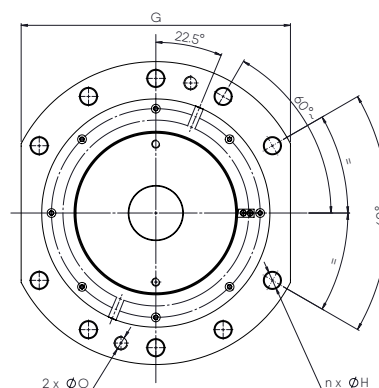
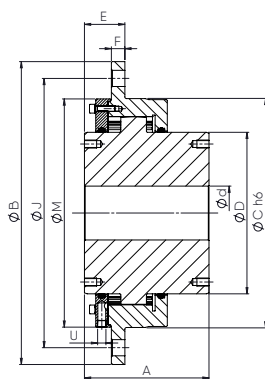

size	SEB	torque FWD		radial load	Ød min. (1)	Ød max. (2)	A	ØB	ØC	ØD	E	F	G	ØH	J	ØM	n	O	U	weight (3)	inertia J (3)	max. misalignment		
		nominal T <sub>n</sub>	peak T <sub>p</sub>																			angular	axial (±)	
		kNm	kNm	kN	dimensions mm															Inch	kg	kgm <sup>2</sup>	degree	mm
FWD																								
150	SG130	37	74	88	65	150	170	400	280	220	45	15	360	19	360	279	10	M16	1/8	69	0.78	0.75	7.0	
170	SG140	62	124	112	80	170	185	450	340	240	60	20	400	24	400	339	10	M20	1/4	105	1.69	0.75	8.0	
220	SG185	130	260	188	120	220	240	550	420	320	60	20	500	24	500	419	10	M20	1/4	198	4.7	0.75	8.0	
250	SG200	160	320	221	150	250	260	580	450	350	60	20	530	24	530	449	14	M20	1/4	235	6.4	0.75	8.0	
280	SG240	310	620	314	180	280	315	650	530	410	65	25	580	24	600	529	14	M20	1/4	370	13.6	0.75	8.0	
300	SG270	385	770	343	190	300	350	680	560	440	65	25	600	24	630	559	26	M20	1/4	460	18.1	0.75	8.0	
320	SG315	500	1000	399	200	320	380	710	600	470	81	35	640	28	660	599	26	M20	1/4	560	25.2	0.75	10	
380	SG355	660	1320	499	220	380	410	780	670	536	81	35	700	28	730	669	26	M20	1/4	760	42.2	0.75	10	
420	SG400	800	1600	587	260	420	450	850	730	580	81	35	760	28	800	729	26	M20	1/4	940	62	0.75	10	

- (1) Min. finish machine bore diameter
- (2) Max. bore diameter with one keyway acc. DIN 6885/1
- (3) For pre-bored/unbored hubs

- Couplings can be supplied with several options (e.g. end cap, puller holes, set screws, exposed inch, ATEX, Viton O-Ring, surface protection) → refer to page 48 et seqq. (B403a et seqq.)
- For the correct coupling selection please refer to page 14 et seqq. (A150a)
- For special executions or requirements, please contact us
- Technical modifications reserved and given values without engagement

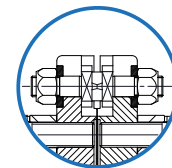
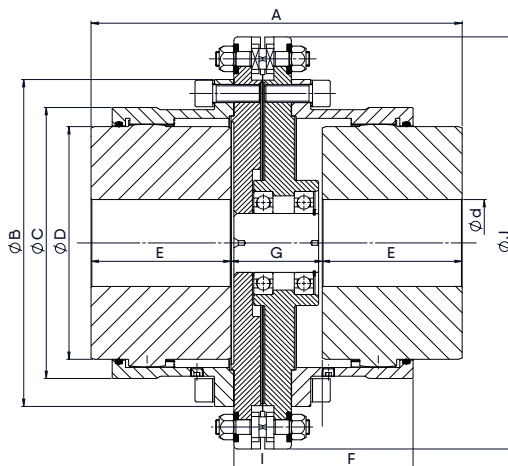
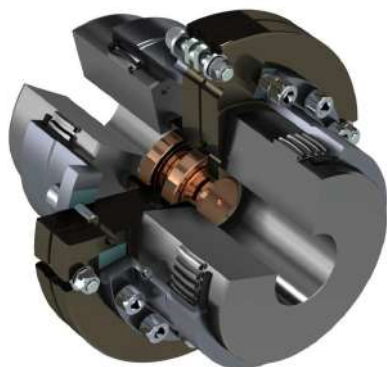

Shear torque  
needs to be specified

size	torque FSP		torque FSUSP (1)		n max.	Ød min. (2)	Ød max. (3)	A	ØB	ØC	ØD	E	F	G	I	ØJ	weight (4)	Inertia J (4)	max. misalignment		
	nominal T <sub>n</sub>	peak T <sub>p</sub>	nominal T <sub>n</sub>	peak T <sub>p</sub>															angular	radial	axial ±
FSP FSUSP	kNm	kNm	kNm	kNm	rpm	dimensions mm										kg	kgm <sup>2</sup>	degree	mm	mm	
45	0.75	1.5	1.5	3.0	4 000	0	50	131	111	80	67	43	41	45	35	155	8.5	0.018	2x0.75	1.2	3.0
60	1.8	3.6	3.6	7.2	3 600	0	64	153	141	103.5	87	50	47	53	44	194	18	0.060	2x0.75	1.4	3.0
75	3.5	7.0	7.0	14	3 300	0	78	185	171	129.5	106	62	58.5	61	44	220	27	0.098	2x0.75	1.6	3.0
95	7.0	14	14	28	2 950	0	98	217	210	156	130	76	68.5	65	48	267	45	0.281	2x0.75	1.9	5.0
110	11	22	22	44	2 550	0	112	247	234	181	151	90	82	67	48	300	64	0.473	2x0.75	2.1	5.0
130	16	31	31	62	2 150	55	132	293	274	209	178	105	98	83	60	358	101	1.13	2x0.75	2.5	6.0
155	22	44	44	88	2 000	65	158	324	312	247	213	120	108.5	84	60	384	141	1.81	2x0.75	2.7	6.0
175	32	63	63	126	1 800	80	175	363	337	273	235	135	121	93	64	428	183	2.85	2x0.75	3.0	8.0
195	44	87	87	174	1 650	90	198	396	380	307	263	150	132	96	64	470	248	4.80	2x0.75	3.2	8.0
215	55	110	110	220	1 450	100	217	467	405	338	286	175	151.5	117	78	524	316	6.82	2x0.75	3.8	8.0
240	81	162	162	324	1 400	120	244	504	444	368	316	190	165	124	78	560	422	10.9	2x0.75	4.1	8.0
275	123	245	245	490	1 350	150	290	579	506	426	372	220	183.5	139	96	656	579	18.4	2x0.75	4.7	10

- (1) Up-rated torque execution
- (2) Min. finish machine bore diameter (size ≥ 130)
- (3) Max. bore diameter with one keyway acc. DIN 6885/1
- (4) For pre-bored/unbored hubs

- Couplings can be supplied with several options (e.g. end cap, puller holes, set screws, exposed inch, ATEX, Viton O-Ring, surface protection) → refer to page 48 et seqq. (B403a et seqq.)
- For the correct coupling selection please refer to page 14 et seqq. (A150a)
- For special executions or requirements, please contact us
- Technical modifications reserved and given values without engagement

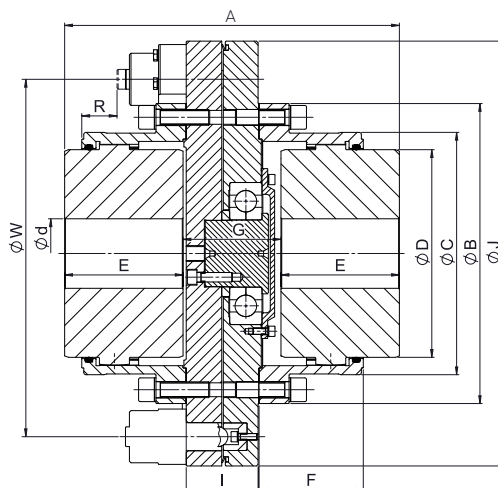

TORQUE CONTROL DEVICES

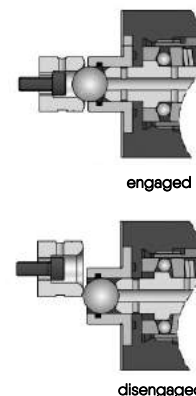

size	torque FET		torque FSUET (1)		n max.	Ød min. (2)	Ød max. (3)	A	ØB	ØC	ØD	E	F	G	I	ØJ	R	ØW	weight (4)	Inertia J (4)	max. misalignment				
	nominal T <sub>n</sub>	peak T <sub>p</sub>	nominal T <sub>n</sub>	peak T <sub>p</sub>																	angular	radial	axial ±		
FET FSUET	kNm	kNm	kNm	kNm	rpm	dimensions mm															kg	kgm <sup>2</sup>	degree	mm	mm
45/1	1.3	2.6	2.6	5.2	4 000	0	50	143	111	80	67	43	41	57	53	288	-15.5	230	29	0.266	2x0.75	0.5	3.0		
60/1	3.0	5.6	6.0	11	3 600	0	64	161	141	103.5	87	50	47.0	61	53	288	-9.5	230	33	0.271	2x0.75	0.7	3.0		
75/1	5.0	8.2	10	16	3 300	0	78	193	171	130	106	62	58.5	69	53	288	1	230	42	0.323	2x0.75	0.8	3.0		
95/2	10	16	20	31	3 950	0	98	228	210	156	130	76	69	76	55	350	16	292	68	0.733	2x0.75	1.0	5.0		
110/2	16	16	32	64	2 550	0	112	258	234	181	151	90	82	78	89	350	29	292	83	0.862	2x0.75	1.1	5.0		
130/3	22	44	44	88	2 150	55	132	325	274	209	178	105	98	115	92	464	13	390	184	3.84	2x0.75	1.4	6.0		
155/3	32	57	64	128	2 000	65	158	356	312	247	213	120	109	116	92	464	21	390	222	4.59	2x0.75	1.5	6.0		
175/4	45	90	90	180	1 800	80	175	391	337	273	235	135	121	121	92	538	35	464	290	7.83	2x0.75	1.7	8.0		
195/4	62	91	124	248	1 650	90	198	424	380	307	263	150	132	124	91	538	45	464	339	8.74	2x0.75	1.8	8.0		
215/4	84	168	168	336	1 450	100	217	512	405	338	286	175	152	162	123	706	13	582	587	26.4	2x0.75	2.2	8.0		
240/5	115	230	230	248	1 400	120	244	549	444	368	316	190	165	169	123	706	37	582	681	31.6	2x0.75	2.3	8.0		
275/6	174	348	348	336	1 350	150	290	630	506	426	372	220	183.5	190	147	844	80.5	720	1 017	58.9	2x0.75	2.7	10		

- (1) Up-rated torque execution
- (2) Min. finish machine bore diameter (size ≥ 130)
- (3) Max. bore diameter with one keyway acc. DIN 6885/1
- (4) For pre-bored/unbored hubs

- Couplings can be supplied with several options (e.g. end cap, puller holes, set screws, exposed inch, ATEX, Viton O-Ring, surface protection) → refer to page 48 et seqq. (B403a et seqq.)
- For the correct coupling selection please refer to page 14 et seqq. (A150a)
- For special executions or requirements, please contact us
- Technical modifications reserved and given values without engagement

## Further details and options

### Flange connection

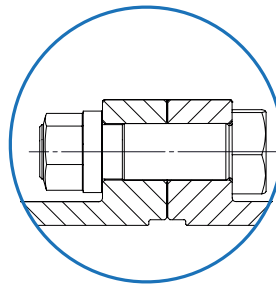
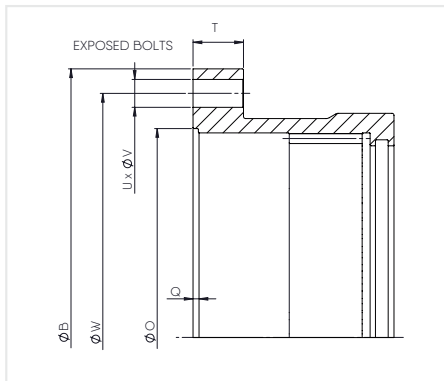

Exposed

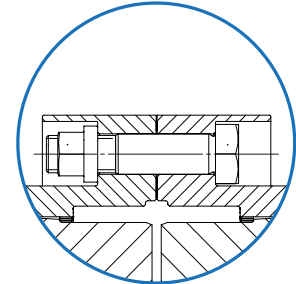

Shrouded

		Size [AGMA]	45 [1]	60 [1 1/2]	75 [2]	95 [2 1/2]	110 [3]	130 [3 1/2]	155 [4]	175 [4 1/2]	195 [5]	215 [5 1/2]	240 [6]	275 [7]	280 [8]	320 (2)	360N (2)	400N (2)	450N (2)
Flange Connection	B	mm	111	141	171	210	234	274	312	337	380	405	444	506	591	640	684	742	804
	O	mm	78	100	120	144	170	198	234	256	290	315	345	400	451	483	540	590	660
	Q	mm	3.5	3.5	3.5	3.5	3.5	3.5	3.5	4	4	4	6	8	8	8	8	10	10
	T	mm	14	19	19	22	22	28.5	28.5	28.5	38	38	26	28.5	33	38	38	38	38
Exposed Metric (E.M.) (1)	U	Qty.	6	8	6	6	8	8	8	10	10	14	14	16	14	18	24	28	30
	V	mm	9	11	13	17	17	21	21	21	21	21	25	25	32	32	32	32	32
	W	mm	96	122	150	184	208	242	280	305	345	368	406	460	530	580	624	682	744
Exposed Inch (E.I.) (1)	U	Qty.	6	8	6	6	8	8	8	10	8	14	14	16	16				
	V	inch	0.250	0.375	0.500	0.625	0.625	0.750	0.750	0.750	0.875	0.875	0.875	1.000	1.125				
	W	inch	3.750	4.812	5.875	7.125	8.125	9.500	11.000	12.000	13.500	14.500	15.750	18.250	20.750				

### Endcap execution

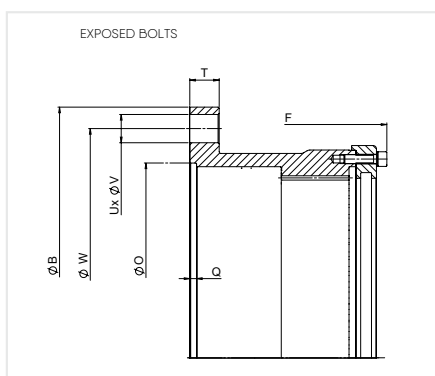

Endcap			
Size	F	No of screws	T2
	mm		Nm
45	n/a	n/a	n/a
60	n/a	n/a	n/a
75	64.8	12	4
95	74.8	10	8
110	88.3	12	8
130	104.3	16	8
155	114.8	20	8
175	128.3	20	13
195	139.3	24	13
215	160.8	16	33
240	174.3	20	33
275	192.8	24	33
280	226.3	20	65
320	235.3	20	65
360N	252.3	24	65
400N	271.8	24	112
450N	285.8	24	112

- 1) The standard couplings are with Exposed bolts execution, for special shrouded bolts execution please contact us.
- 2) For Exposed Inch execution please contact us.

## Puller holes and set screw

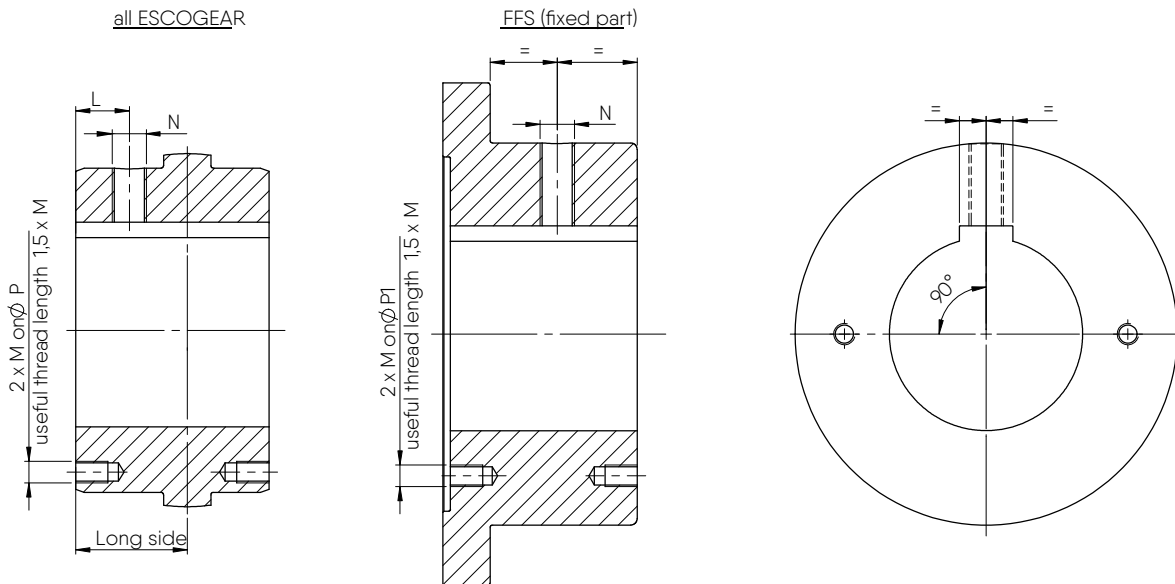

Size	Puller holes (mm) 1)			Set screw (mm)	
	M	P	P1 (FFS)	L	N
45	M5	58	58	15	M6x6
60	M6	76	76	12	M6x6
75		94	94	22	M10x10
95	M8	114	114	26	M12x12
110	M10	132	132	32	M16x16
130		155	155	38	
155		186	186	42	M20x20
175	M12	205	235	50	
195	M16	226	265	55	M24x24
215		250	290	65	
240		276	320	70	
275	M20	330	370	82	M24x24
280		336	416	100	
320		377	456	106	
360N	M24	420		114	M30x40
400N		480		129	
450N		544		142	

## Balancing

Thanks to our high manufacturing quality, ESCOGEAR couplings have a high degree of natural inherent balance and generally don't require additional balancing for normal speed (N1) applications. Up to size 195, FST couplings have a minimum balance quality of Q6.3 at 800 rpm. For larger sizes, Q6.3 is reached without any additional balancing until 400 rpm.

Special balancing can be done on request. For higher speed bigger than N1 special balancing is mandatory.

1) Puller holes available as options from size 45 - 155. For sizes 175 and bigger puller holes are included by default

## Shaft connection

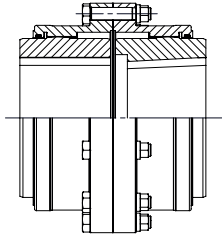

KEYWAY

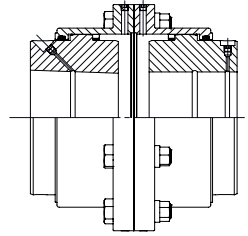

INTERFERENCE FIT

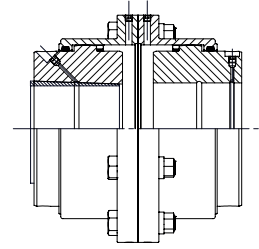
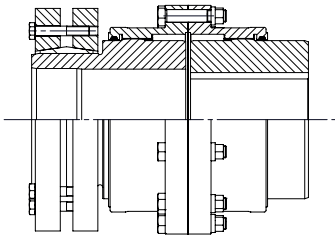
INTERFERENCE WITH  
INTERMEDIATE CONICAL BUSHING

EXTERNAL CLAMPING

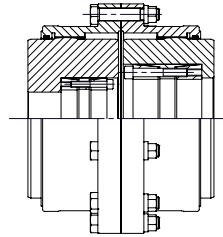

INTERNAL CLAMPING

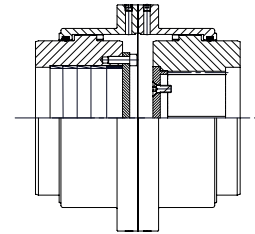

SPLINES

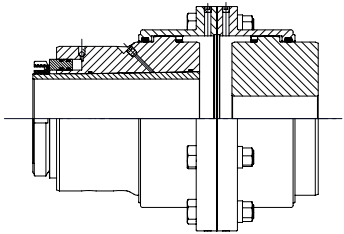

HYDRAULIC BUSHING

## Protection

Coupling parts up to size 320 are black oxidized by default. Above that size coupling parts are oil waxed. Fitted bolts and screws are GEOMET 500 coated and nuts zinc plated. Additional black oxide or special paintings can be done on request.

Notes:

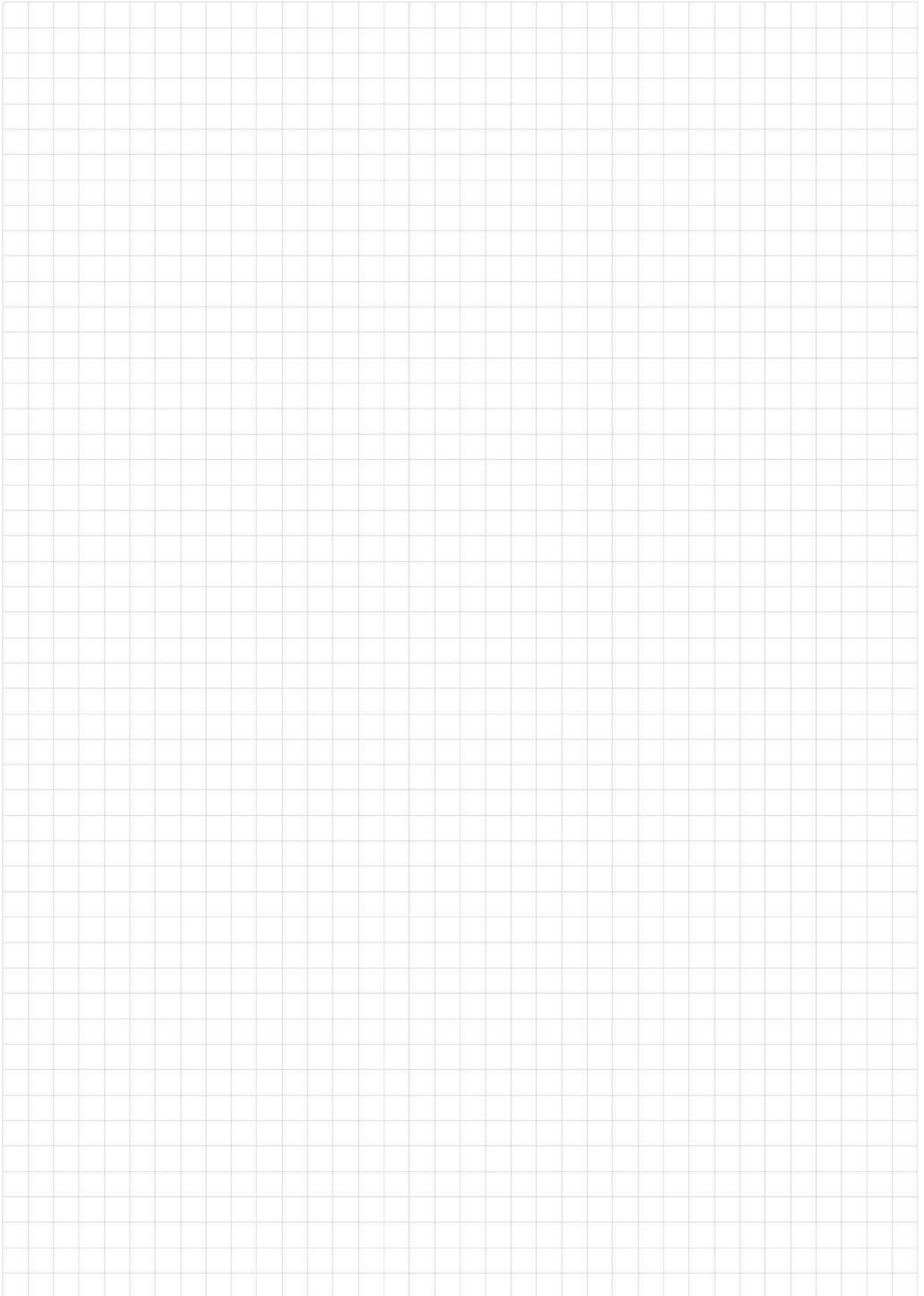

## Further designs and combinations

All ESCOGEAR couplings can be combined and extended almost without limit.  
Please contact us for further details.

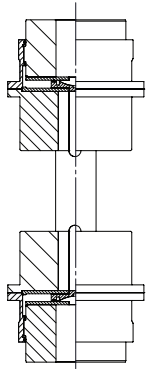

FLOATING SHAFT VERTICAL  
WITH AXIAL LOAD

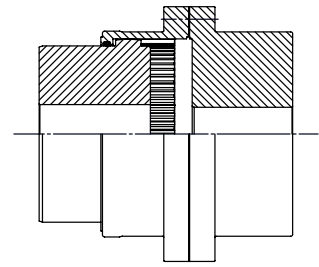

FLOATING SHAFT WITH MILL-  
MOTOR SLIDING HUB

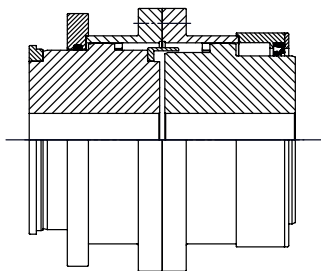

SHIFTABLE AS STANDSTILL

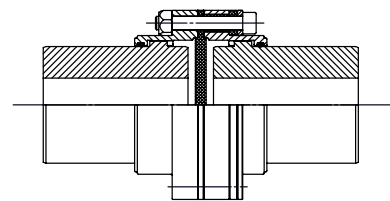

ELECTRICAL INSULATED

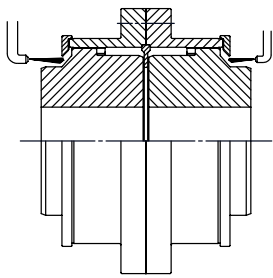

OIL FLOW

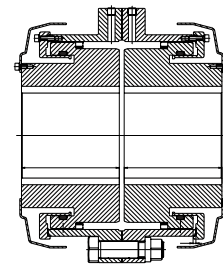

SPECIAL PROTECTION  
COVER

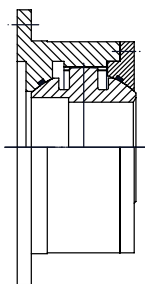

BALL TYPE

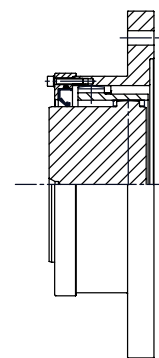

FLYWHEEL ADAPTER

## Further designs and combinations

All ESCOGEAR couplings can be combined and extended almost without limit.  
Please contact us for further details.

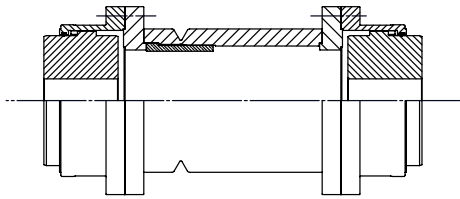

OVERLOAD SPACER

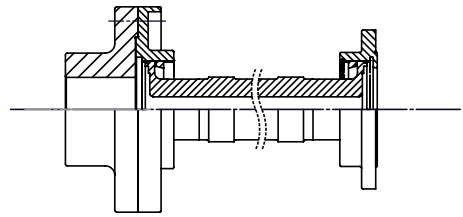

HIGH SPEED

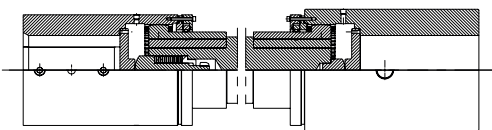

GEAR SPINDLE

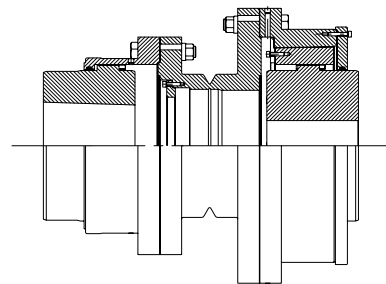

TORQUE LIMITING

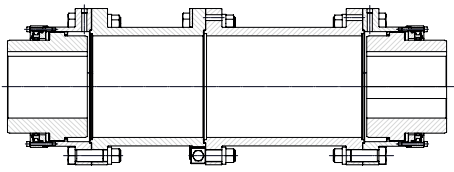

RADIAL ADJUSTABLE  
*Higher misalignment capacity*

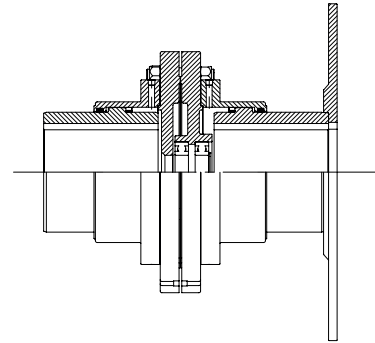

SEPARATE BRAKE DISC  
*Shear pin with brake disc*

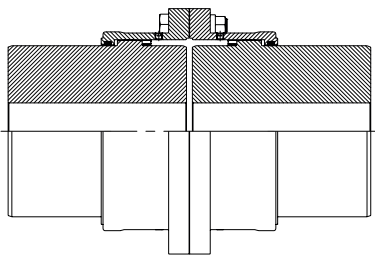

EXTRA LONG HUBS

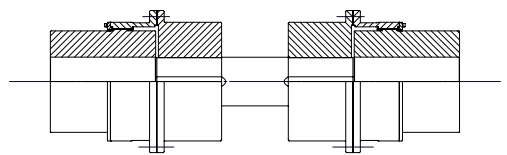

FLOATING SHAFT MILL-MOTOR

# Installation and maintenance

## F Series

### 1) Introduction

Coupling must be properly selected according to selection chart on page A150a and corresponding charts. These documents are available in coupling catalogue ESCOGEAR F series or on our website „www.escogroup.com“.

Maximum misalignment figures during assembly and operations are given in above-cited document (values used in section 4) Assembly). Maximum misalignment, speed and torque may not be applied simultaneously as mentioned in the selection chart.

In case of any change or adaptation not performed by ESCO on the coupling, it is customer's responsibility to size and manufacture it properly to guarantee safe torque transmission and absence of unbalance that could affect the life of the coupling and the connected machines.

If the interfaces are not calculated and machined by ESCO, it is customer's responsibility to make sure that:

- In case of key
  - Shaft and key material, size and tolerance to suit the application
  - Hub length, bore diameter and machining tolerances will allow to transmit the torque; maximum bore capacity is given for information in the catalogue for DIN 6885/1 or NF E22-175.
- In case of interference fit
  - Interference and machining tolerances will transmit the torque and not exceed the permissible stress of hub material.

In case of spacer or floating shaft not supplied by ESCO, it is customer's responsibility to size and manufacture it properly to guarantee safe torque transmission and absence of unbalance that could affect the life of gearing on the connected machines.

The hubs must be axially secured on the shaft by means of either a setscrew or an end plate or a sufficient interference. It is customer's responsibility to protect the coupling and to comply with the local safety rules regarding the protection of rotating parts.

e.g.: coupling guards

### 2) Preparation

Ensure the conformity of the supplied equipment:

- Verify coupling size and conformity (see catalogue or website)
- Check for any damaged and/or missing parts
- Verify conformity of the coupling/machine interfaces
- Coupling original protection allows for storage indoors dry 18 months, indoors humid 12 months, outdoors covered 9 months and outdoors open 3 months. For longer periods, it is customer's responsibility to protect the parts properly.
- Instructions are a part of the supply of the coupling. Be sure that valid and complete „Assembly, operation and maintenance instructions“ are available and well understood. In case of doubt, refer to ESCO.

Before starting, verify the availability of the necessary tooling to:

- Manipulate the parts
- Assemble the interfaces
- Align the coupling
- Tighten the screws and nuts

Assembly, disassembly and maintenance must be performed by qualified, trained and competent fitters.

### 3) Warnings

In-charge installer and plan foreman are responsible of the installation safety. All adequate safety rules must be put in place for the assembly process.

Before removing the coupling guard and proceeding with any assembly, operation or maintenance operation of the coupling, make sure the complete system is completely shut down and definitively disengaged from any possible source of rotation, such as e.g.: electrical power supply or any loss of

braking effect.

Make sure everyone present in the equipment area will be properly informed (for example by means of warnings properly located) about the maintenance or assembly situation. In case of use in explosive atmospheres  $\text{Ex}$  specific protective measures must be considered.

They are described in an extra attachment (IM/A200d-EX) to the instructions with the couplings marked  $\text{Ex}$ .

### 4) Assembly

#### 4.1. Coupling without end-cap

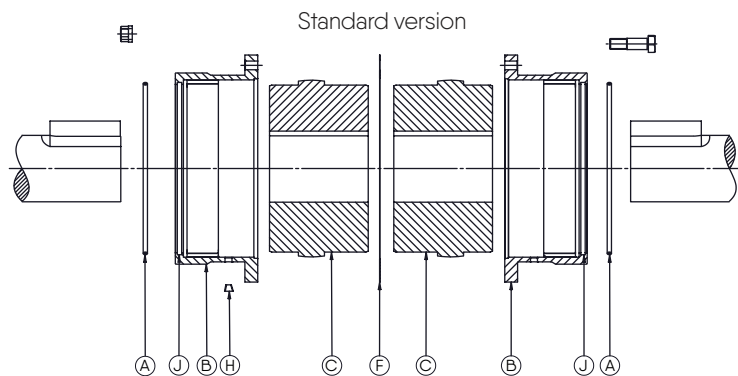

- 4.1.1. Ensure all parts are clean.
- 4.1.2. Apply a light coat of grease to the O-Rings (A) and insert O-Rings into grooves (J) of sleeves (B).
- 4.1.3. Place sleeves (B) over shaft ends; care should be taken not to damage O-Rings (A).
- 4.1.4. Install hubs (C) on their respective shafts with the longest hub end towards shaft end or towards machine bearing depending on the type (see figure 1 and 3).  
If needed, for keyway assembly, uniformly heat hubs (C) (max. 120°C) to install them easily on the shaft; in this case, avoid any contact between the hub (C) and O-Ring (A).  
Hub face has to be flush with shaft end; in case of doubt, please consult ESCO.  
Introduce setscrew on key with adapted self-locking paste and tighten properly.  
In case of interference fit, refer to ESCO for proper instructions.
- 4.1.5. Install units to be connected in place and check the spacing „G“ between hubs; see tabulation 1 according to coupling size or approved drawing for correct „G“ value.  
In case of doubt, please consult ESCO.

- 4.1.6. Align both shafts and check alignment using an indicator; for alignment precision, see tabulation 4.
- 4.1.7. Coat hub and sleeve gearings with grease (see tabulation 3) and slide sleeves (B) over hubs.
- 4.1.8. Insert the gasket (F) between flanges of sleeves (B) and bolt sleeves together, tighten bolts uniformly; see tabulation 2 for correct tightening torque (“T1” Nm).
- 4.1.9. Make sure that sleeves are freely sliding over hubs by axially displacing it to a value equal to „G“ (see tabulation 1).
- 4.1.10. For the types
  - FST, FMM and FDMM, remove both lube plugs (H) of one sleeve (B) and add grease in sufficient amount to overflow with lubricant holes in horizontal position
  - FFS, FSE, FSLE, FLE, FSP, FIN and FSV repeat this operation for the second sleeve
  - FSV consult ESCO
 Re-install both plugs (H); see tabulation 2 for correct tightening torque (“T3” Nm) and key size (“s” mm)  
For quantity and quality of grease, see tabulation 3

## 4.2. Coupling with end-cap

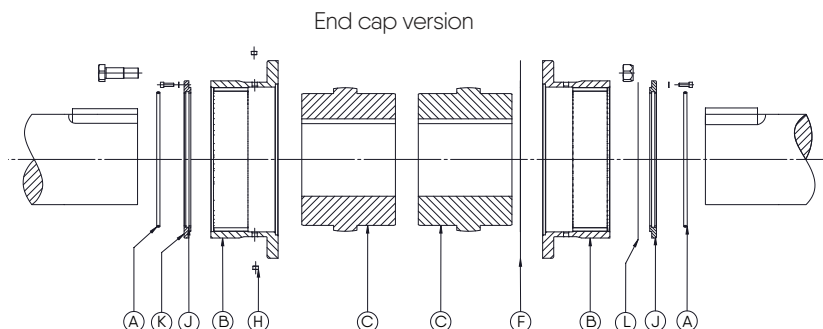

- 4.2.1. Ensure all parts are clean.
- 4.2.2. Apply a light coat of grease to the O-Rings (A) and insert O-Rings into grooves (J) of end caps (K).
- 4.2.3. Place end cap (K) and gasket (L) over shaft ends. Care should be taken not to damage O-Rings (A) and the gasket (L).
- 4.2.4. Install hubs (C) on their respective shafts with the longest hub end towards shaft end or towards machine bearing depending on the type (see figure 1 and 3).  
If needed, for keyway assembly, uniformly heat hubs (C) (max. 120°C) to install them easily on the shaft; in this case, avoid any contact between the hub (C) and O-Ring (A).  
Hub face has to be flush with shaft end; in case of doubt, please consult ESCO.  
Introduce setscrew on key with adapted self-locking paste and tighten properly.  
In case of interference fit, refer to ESCO for proper instructions.
- 4.2.5. Place sleeves (B) over shaft ends.
- 4.2.6. Install units to be connected in place and check the spacing „G“ between hubs; see tabulation 1 according to coupling size or approved drawing for correct „G“ value.  
In case of doubt, please consult ESCO.
- 4.2.7. Align both shafts and check alignment using an indicator; for alignment precision, see tabulation 4.
- 4.2.8. Coat hub and sleeve gearings with grease (see tabulation 3) and slide sleeves (B) over hubs.
- 4.2.9. Assemble end caps (K) and gaskets (L) on sleeves (B) with screws and locking washers, tighten screws uniformly; see tabulation 2 for correct tightening torque (‘‘T2’’ Nm) and key size (‘‘s’’ mm).

- 4.2.10. Insert the gasket (F) between flanges of sleeves (B) and bolt sleeves together, tighten bolts uniformly; see tabulation 2 for correct tightening torque (‘‘T1’’ Nm).
- 4.2.11. Make sure that sleeves are freely sliding over hubs by axially displacing it to a value equal to „G“ (see tabulation 1).
- 4.2.12. For the types
- FST, FMM and FDM, remove both lube plugs (H) of one sleeve (B) and add grease in sufficient amount to overflow with lubricant holes in horizontal position
  - FFS, FSE, FSLE, FLE, FSP, FIN and FSV repeat this operation for the second sleeve
  - FSV consult ESCO
- Re-install both plugs (H); see tabulation 2 for correct tightening torque (‘‘T3’’ Nm) and key size (‘‘s’’ mm)  
For quantity and quality of grease, see tabulation 3

## 5) Inspection and maintenance

- 5.1. Inspection  
regular inspection (audio-visual) must occur for leakage, noise, vibration and loss of parts.
- 5.2. Maintenance
- 5.2.1. Every 4 000 hours or every day  
Check that sleeves are freely moving axially; follow instruction as indicated in point 4.1.9. or 4.2.11.  
Fill up grease level; proceed as mentioned und 4.1.10. or 4.2.12.
- 5.2.2. Every 8 000 hours or every 2 years  
Remove screws, nuts and gasket (F).  
Clean and control gearing and sealing.  
Control alignment; see point 4.1.6. or 4.2.7.  
Reassemble coupling as per point 4; it is recommended to replace gasket (F), screws and nuts at every reassembly.

6) Tabulation and figures

TABLE 1 - DISTANCE BETWEEN SHAFT ENDS IN DIFFERENT COUPLING TYPES								
TYPE SIZE	FST, FMM, FDMM, FLE, G mm	FFS G mm	FSP G mm	FSH (min.) G mm	FSV G mm	FRR G mm	FET G mm	FIN G mm
45	3	2 x 5	45	8	8	7		
60	3	2 x 5	53	8	5	7	61	7
75	3	2 x 5	61	8	12.5	7	69	8
95	5	2 x 6	65	10	11	7	76	11
110	5	2 x 6	67	10	13	7	78	11
130	6	2 x 6.5	83	11	14	7	115	12
155	6	2 x 6.5	84	11	15	7	116	12
175	8	2 x 8	93	14	17	8	121	14
195	8	2 x 8	96	14	20	8	124	14
215	8	2 x 8	117	16	27	8	162	14
240	8	2 x 10	124	16	34	12	169	16
275	10	2 x 13	139	18	28	16	190	
280	10	2 x 13			570	16		
320	13	2 x 14.5			597	16		
360N	13	2 x 14.5			638	16		
400N	13	2 x 14.5			689	16		
450N	13	2 x 16			737	20		
500	19							
530	19							
560	19							
600	25							
660	25							
730	25							
830	25							
900	25							
1 000	25							
1 060	25							
1 130	25							

TABLE 2 - TIGHTENING TORQUES											
Type	Flange						End Cap			Plug	
	Exposed Metric bolts Socket			Exposed Inches bolts Socket			T 2	Hexagonal Socket head screw		T3	s
	T1 Nm	Size mm	Driver inch	T1 Nm	Size mm	Driver inch	Nm	M mm	s inch	Nm	mm
45	33.5	10	1/4"	15	3/8"	1/4"				7	4
60	66	12	3/8"	49	1/2"	3/8"				10	5
75	112	14	3/8"	118	5/8"	1/2"	4	4	3	10	5
95	277	19	1/2"	236	25/32"	1/2"	8	5	4	10	5
110	277	19	1/2"	236	25/32"	1/2"	8	5	4	10	5
130	537	24	1/2"	413	15/16"	1/2"	8	5	4	10	5
155	537	24	1/2"	413	15/16"	1/2"	8	5	4	10	5
175	537	24	1/2"	413	15/16"	1/2"	13	6	5	10	5
195	537	24	1/2"	569	17/16"	1/2"	13	6	5	10	5
215	537	24	1/2"	569	17/16"	1/2"	33	8	6	29	8
240	795	30	3/4"	569	17/16"	1/2"	33	8	6	29	8
275	795	30	3/4"	795	19/16"	3/4"	33	10	6	29	8
280	1 855	46	1"				65	10	8	29	8
320	1 855	46	1"				65	10	8	29	8
360N	1 855	46	1"				65	10	8	29	8
400N	1 855	46	1"				112	12	10	29	8
450N	1 855	46	1"				112	12	10	29	8

For FIN and FWD types, refer to factory

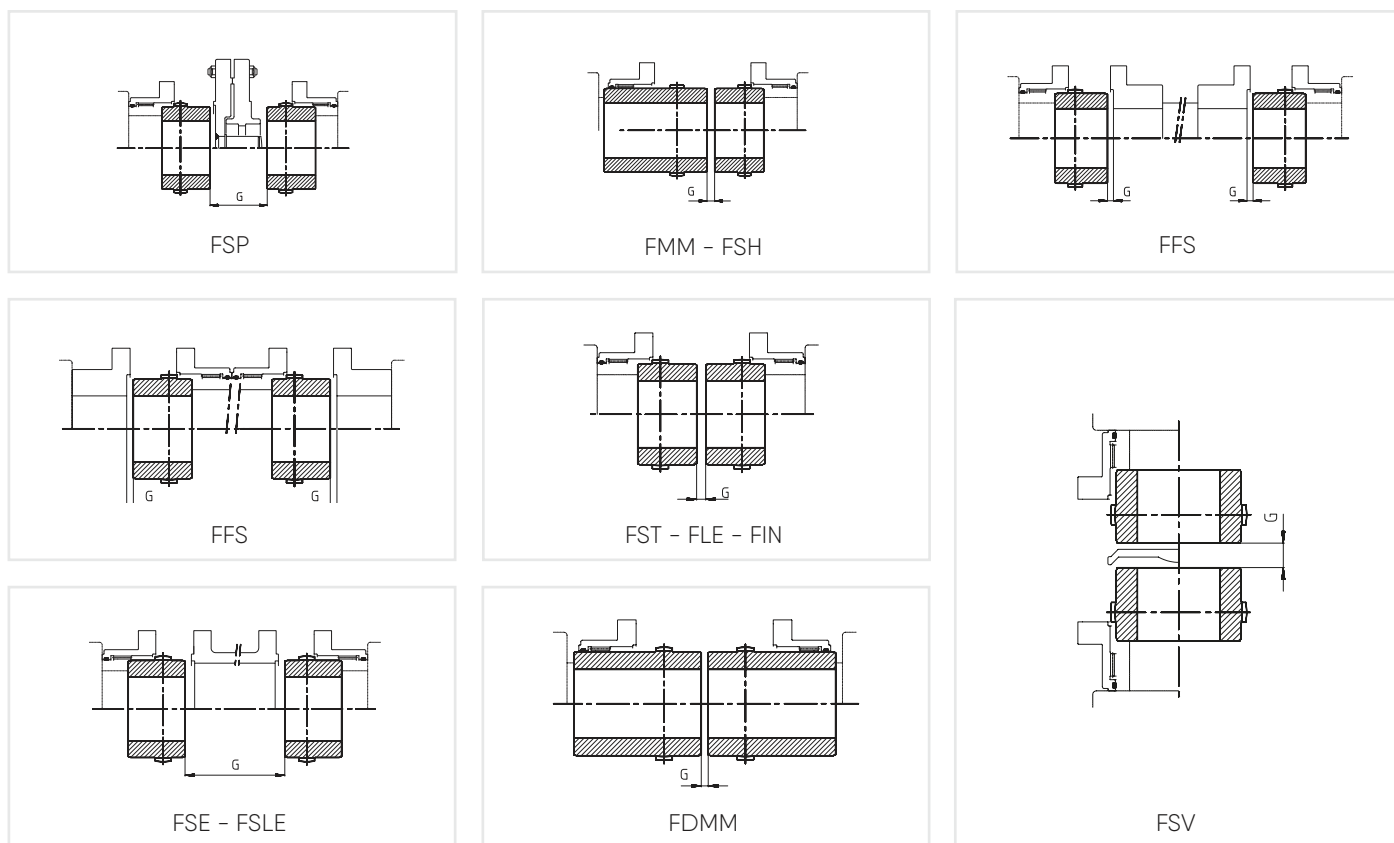

TABLE 3 – RECOMMENDED LUBRICANTS AND QUANTITY				TYPE SIZE	FST FMM FDMM dm <sup>3</sup>	FFS FSE FSLE dm <sup>3</sup>	FLE FSP FIN dm <sup>3</sup>	FSV dm <sup>3</sup>	FSH	FWD
NORMAL SPEED AND DUTY		HIGH SPEED, HEAVY DUTY AND ATEX								
Eni	GR MU/EP1			45	0.04		2 x 0.021	0.039		
Caltex	Coupling Grease	Caltex	Coupling Grease	60	0.07	2 x 0.04	2 x 0.034	0.057		
Chevron	Coupling Grease	Chevron	Coupling Grease	75	0.11	2 x 0.07	2 x 0.057	0.118		
Klüber	Klüberplex GE 11-680	Klüber	Klüberplex GE 11-680	95	0.19	2 x 0.10	2 x 0.093	0.187		
Mobil	Mobilux EP0 or EP 004	Mobil	Mobilgrease XTC	110	0.33	2 x 0.17	2 x 0.165	0.316		
Mobil	Mobilgrease XTC	Texaco/ Multifak	Coupling Grease	130	0.48	2 x 0.24	2 x 0.238	0.465		
Q8	Rembrandt EPO			155	0.74	2 x 0.38	2 x 0.370	0.739		
Shell	Gadus S2 V220			175	0.89	2 x 0.45	2 x 0.445	0.872		
Shell	Gadus S3 V220C			195	1.39	2 x 0.70	2 x 0.695	1.403		
Texaco/ Multifak	Coupling Grease			215	1.87	2 x 0.92	2 x 0.934	1.909		
Total	MULTIS EP 1			240	2.26	2 x 1.17	2 x 1.128	2.437		
				275	3.40	2 x 1.60	2 x 1.701	0.731		
				280	6.07	2 x 2.60				
				320	7.81	2 x 3.95				
				360N	9.16	2 x 4.20				
				400N	11.66	2 x 6.30				
				450N	13.62	2 x 7.20				

**Tabulation 4: Alignment precision**

Alignment is measured as shown on the figure (Y-Z) for angular and X for offset.

Combination of angular and offset misalignment must comply with the following formulation:

$$\Delta K_w \min \leq \frac{X}{K_x} + \frac{Y-Z}{K_y} \leq 0.75 \times \Delta K_w \max.$$

$$\Delta K_w \min = 01^\circ$$

$\Delta K_w \max$  depends on speed and torque as shown on graph (T, n) in coupling on page A150 (a).

$$K_x = K_{x0} + \frac{S}{30} \text{ with } S = \text{Spacer length (mm)}$$

(If no spacer: S = 0)

$$K_y = K_{y0}$$

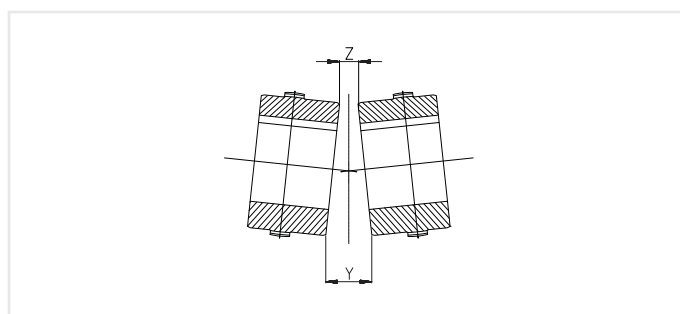
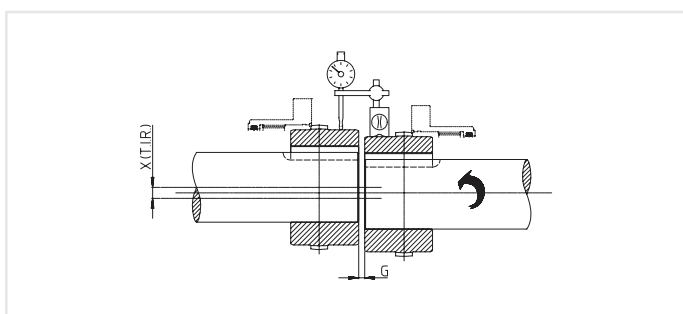

FST	Kx0	Ky0
45	1.92	2.34
60	2.06	3.04
75	2.76	3.71
95	3.25	4.54
110	3.80	5.28
130	4.47	6.22
155	5.03	7.55
175	5.72	8.20
195	6.35	9.18
215	7.47	9.98
240	8.24	11.04
275	9.18	12.98
280	10.82	13.76
320	11.34	15.08
360	12.32	16.76
400	13.37	18.50
450	14.35	20.74

# ATEX

## Specific protective measures taken for ESCOGEAR couplings in case of use in explosive atmospheres.

### 1) Introduction

General assembly and maintenance instructions (called IM in this attachment) are established for standard ESCOGEAR couplings according to the following list:

- IM/A200 for ESCOGEAR NST couplings
- IM/A300 for ESCOGEAR CST couplings
- IM/B300 for ESCOGEAR CST-M couplings
- IM/B400 for ESCOGEAR FST couplings

**In case of use in potentially explosive atmospheres, further to the general assembly and maintenance instructions (IM/...), the specific measures described in this attachment must be taken.**

### 2) Coupling Selection

The coupling must be selected according to the general assembly and maintenance instruction IM/...

In explosive atmosphere  $\text{Ex}$ , the following specific rules must apply:

- A Service Factor of 2 must be applied on the max. torque values given in the charts in catalogue (see Selection chart A150ff.).
- A Service Factor of 2 must be applied on the reference torque values given on the selection chart A150a for the calculation of max. misalignment in operation.
- Max. misalignment (combination of angular and offset) may not exceed  $0.5^\circ$  per gear mesh.

### 3) Use of the coupling

The coupling is dedicated to be used in potentially explosive atmospheres according to European Directive 2014/34/EU (ATEX 100A).

Coupling is classified in equipment group II, equipment category 2 and 3, intended to be used in areas in which explosive atmospheres caused by gases, vapours, mists of air/dust mixtures are likely to occur.

In function of the ambient temperature in the coupling proximity (65, 55,  $40^\circ\text{C}$ ), the temperature classes have been defined (T4, T5, T6).

This is based on a temperature increase of the machine shafts (in regard of the ambient temperature) that will not exceed  $40^\circ\text{C}$  in operation.

The coupling is marked as follows:

**CE  $\text{Ex}$  II 2 G T4/T5/T6 D  $105^\circ\text{C}$   
 $-20^\circ\text{C} \leq T_a \leq 65^\circ\text{C}/55^\circ\text{C}/40^\circ\text{C}$**

This marking covers the T3 temperature category.

This marking covers all gas categories: G IIA, G IIB and G IIC.

### 4) Warnings

The warnings mentioned in the general assembly and maintenance instructions IM/... must apply in any case.

In explosive atmospheres  $\text{Ex}$ , the following specific warnings must apply:

- Complete machining of the coupling parts (bores, keyways, spacers, floating shafts etc...) must be performed by ESCO Couplings SRL. No modification shall be made on the supplied and marked product without the agreement of ESCO Couplings SRL.
- In case of supply by ESCO Couplings SRL of couplings with a rough bore or a solid bore, the sole allowed operation that may be performed by customer is the boring and keywaying of the coupling hubs.

When machining the bore and the keyway, the following instructions must be followed:

- This job must be performed by an authorised and adequately trained and informed operator.
- The bore and keyway tolerances must be selected to ensure the proper fit between shaft and bore. In case of loose fit, a set screw must be foreseen to locate the hub axially.
- The max. bore may not exceed the value stated in the catalogue. The tabulated values in the catalogue are based on key dimensions according to ISO R773.
- The reference used to center the piece when boring, is the one referenced D in the figures of the catalogue.
- Before proceeding with any assembly, operation or maintenance operation on the coupling, make sure that the necessary measures have been taken to ensure safety, such as but not limited to:
  - Proper ventilation if the area
  - Proper lightening and electrical tools.
- If hub must be heated for assembly on the shaft, make sure heating source and surface temperature will not affect the safety of the working area.

- It is recommended to have a strong coupling guard, preferably in stainless steel with openings (if any) smaller than the smallest centrifugable part (plug is 6 mm dia). The coupling guard is intended to protect the environment from the centrifugation of any rotating part and the rotating coupling from any falling part. To limit ventilation effects, distance between cover and coupling outside surface should be at least 10 mm.

## 5) Assembly

The general assembly and maintenance instructions IM/... must apply in any case.

In explosive atmospheres  $\text{Ex}$ , the following specific instructions must apply:

- Alignment of the machine in cold condition must take into account the possible heat expansion to make sure that in continuous running conditions, max. misalignment calculated in 6.1. will not be exceeded.
- Max. misalignment may never exceed  $0.5^\circ$  per gear mesh.
- To improve the coefficient of friction and the leakage resistance, use following lubricants dedicated for gear couplings:
  - CHEVRON Coupling Grease
  - CALTEX Coupling Grease
  - KLÜBER Klüberplex GE11-680
  - MOBIL Mobilgrease XTC
  - TEXACO/MULTIFAK Coupling Grease

## 6) Operation

The general assembly and maintenance instructions IM/... must apply in any case.

In explosive atmospheres  $\text{Ex}$ , the following specific instructions must apply:

- Before Start-up
  - Make sure, screws, nuts and plugs are properly tightened.
  - Coupling guard must be properly installed and fixed.
  - Monitoring system, if any, must be tested to verify its effectiveness.

- During start up
  - Check for any leakage. In case of abnormal leakage, immediate stop is mandatory and appropriate actions must be taken.
  - Check for any abnormal noise and/or vibration. If any, immediate stop is mandatory and appropriate actions must be taken.
- Checking intervals during operation
  - After the first 2 000 hours or 6 months: check
    - For leakage, noise, vibration and loss of parts.
    - For free axial movement of the sleeves in regard of the hubs.
  - After 4 000 hours or one year
    - For leakage, noise, vibration and loss of parts.
    - For free axial movement of the sleeves in regard of the hubs.
- Continuous checking
  - Immediately stop the machine if noise, vibrations or other abnormal phenomena are detected during operation.
  - Further more, if direct check is not possible for access or safety reasons, proper monitoring system has to be installed to follow up couplings behaviour.

## 7) Maintenance

The general assembly and maintenance instructions IM/... must apply in any case.

In explosive atmospheres  $\text{Ex}$ , the following specific instructions must apply:

- Every 6 000 hours or 1.5 years:
  - Dismount the coupling and inspect
  - Proceed as indicated in point 4.3.1.



# ESCO worldwide

## ESCO Couplings SRL

Avenue Ernest Solvay, 48

B - 1480 Saintes

Belgium

Tel + 32 (0) 2 715 65 60

Fax + 32 (0) 2 720 83 62

e-mail: [info@esco-couplings.be](mailto:info@esco-couplings.be)

website: [www.escogroup.com](http://www.escogroup.com)



## ESCO Couplings & Transmissions Pvt. Ltd.

Plot No. 69-D

Bengaluru Aerospace Park

Unachuru Village Jala Hobli

Bengaluru

India

Tel +91 80 7100 1800

e-mail: [info@esco-couplings.co.in](mailto:info@esco-couplings.co.in)

website: [www.escogroup.com](http://www.escogroup.com)

## Local Contact

Authorised distributor



TYMA CZ, s.r.o.

Na Pískách 731/12

CZ - 40004 Trmice, Czech Republic

Phone: +420 475 655 010

Email: [info@tyma.cz](mailto:info@tyma.cz)

[www.tyma.cz](http://www.tyma.cz)

Version 01-2025