

# ESCODISC FIL series

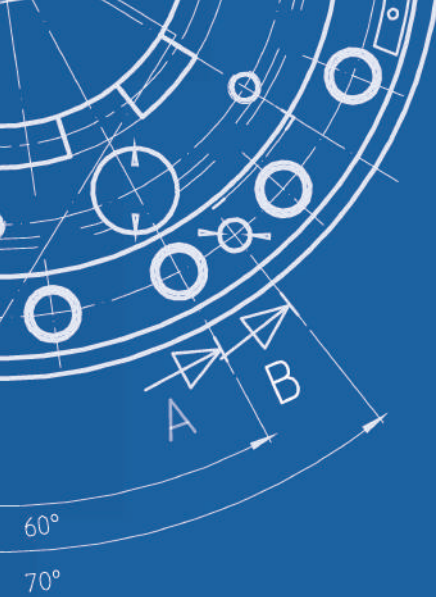



## INDEX

We connect the world .....	5
Global footprint .....	6
The right solution for your application .....	8
Why ESCODISC FIL? .....	10
How to select the right coupling size .....	12
ESCODISC FIL E75-E675 .....	14
Installation and maintenance .....	16
Contact us! .....	20





## We connect the world

We are more than a 75 years old family-owned company specialized in designing and manufacturing high-quality custom-made power transmission products.

Because we believe each transmission challenge is different, we create much more than off-the shelf products: we work hand in hand with our customers to develop the coupling solutions that best fit their specific needs.

Superior product quality is what guarantees our customer's success, it is what enables us to cherish long term partnerships with them. The ESCO quality has been worldly renown for decades and we work tirelessly to raise these standards even further.

We strive to be a significant contributor to the development of effective and clean industrial, transportation and energy supply applications. We want our couplings to power a more sustainable world.

We strongly believe that both the future of our economy and the best guarantee for long term return lie in sustainable development. And we want to do our part.

Once we get involved into a specific sector, we make sure to embrace the quality standards that the market requires. This is why, we are ISO 9001 certified.



A global footprint, with a family of  
9 companies located all across the world



9

offices across  
the world

3

manufacturing  
sites

● ESCO Couplings SRL  
*Saintes, Belgium*  
Tel. +32 (0) 2 715 65 60  
info@esco-couplings.be

● ESCO Couplings & Transmissions Pvt. Ltd.  
*Bengaluru, India*  
Tel. +91 80 7100 1800  
info@esco-couplings.co.in

● ESCO Power SRL  
*Saintes, Belgium*  
Tel. +32 (0) 2 717 64 90  
info@escopower.be

● EFECO Services Pvt. LTd  
*Bengaluru, India*  
Tel. +91 80 4977 7088

● ESCO Couplings Ltd.  
*Jinan, China*  
Tel. 86 (531) 827 625 65  
info@esco-couplings.com



- Head-office & Manufacturing site
- Manufacturing sites
- Sales offices & Service centres

● ESCO Aandrijvingen B.V.  
*Alphen A/D Rijn, The Netherlands*  
Tel. +31 (0) 172 42 33 33  
[info@esco-aandrijvingen.nl](mailto:info@esco-aandrijvingen.nl)

● esco antriebstechnik gmbh  
*Troisdorf, Germany*  
Tel. +49 (0) 2241 48 07 0  
[info@esco-antriebstechnik.com](mailto:info@esco-antriebstechnik.com)

● ESCO Drives SRL  
*Saintes, Belgium*  
Tel. +32 (0) 2 717 64 60  
[sales@esco.be](mailto:sales@esco.be)

● ESCO Transmissions SAS.  
*Saint Witz, France*  
Tel. +33 (1) 34 31 95 95  
[info@esco-transmissions.fr](mailto:info@esco-transmissions.fr)

We work with you to design the right  
solution for your application



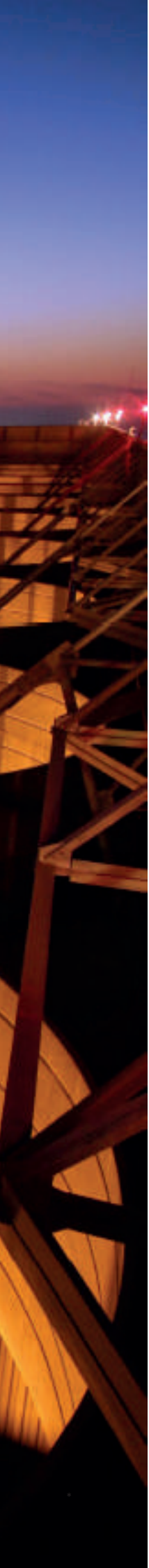

---

Extreme humidity, aggressive chemicals and minerals, important vibrations, these are only a few of the many factors that contribute to the harsh environment in which wet cooling towers operate.

---

Since consistent heat processing is a critical operation of many power and industrial plants, cooling towers need to be able to run continuously, without failure. Furthermore, maintenance operations should be as short and seamless as possible to minimize costly production down time.

Minimizing the life cycle cost of the installation requires careful attention when selecting the elements of the driveline. A high-quality coupling will make a difference between an efficient, cost effective transmission, and a poorly optimized one.

This is where ESCO can help you. We have been helping our customers by designing high-quality tailor-made couplings for more than 40 years:

**Quality is our motto, our core competency:** ESCO products are amongst the most reliable in the market; so much so that the main hurdle in our capacity to innovate is the lack of market feedback: our couplings just keep running without issues.

**Low lifecycle cost might well be the biggest challenge for ESCO to tackle, but we do work tirelessly to optimize the life time value of our couplings:** fair initial price, smaller footprint (space and weight), longer design life, lubrication-free alternatives, extended maintenance steps...

**Service is an important part of our business:** to best serve your needs, you can count on our experienced team and advanced testing capability. We are more than happy to assist in performing field interventions, maintenance and repair.

Our relationship with customers does not stop once couplings are delivered. We have a team of experienced people ready to perform service on the field, repair, inspections, testing... We can also do the maintenance on our couplings for you. This guarantees proper execution of the maintenance instructions and contributes to improving the lifetime of your application.

**ESCO specializes in the design of custom made couplings. If you cannot find a solution that fits your needs, please contact us: we will work hard to engineer the coupling that fits your application specifications.**

## Why ESCODISC FIL?

---

The ESCODISC FIL is a state-of-the-art, long-life, flexible disc coupling made from modern composite materials. This gives the coupling incomparable light weight, high strength, corrosion and ultraviolet resistance.

The ESCODISC FIL coupling has been designed with the customer's interest in mind and it provides significant benefits over alternative transmission solutions.

This coupling particularly stands out as the best choice in the industrial sector of cooling towers and applications with longer DBSE where reducing spacer weight will be a critical criteria.

---

### Ease of installation

- Advanced composite materials offer high resistance for only 25% of the weight of steel. The coupling does not require the use of a crane to be mounted, which makes for very convenient installation and maintenance processes.
- The flexible elements have high misalignment capacity which facilitates assembly of the coupling on the installation.
- The flexible elements are unitized: no washers nor any other hardware to mess with during installation or maintenance.



### Extended life and low cost of ownership

- The ESCODISC FIL coupling has been designed to offer superior strength and endurance: components are dimensioned for infinite life with high resistance against corrosion.
- Lubrication-free couplings such as the ESCODISC FIL greatly reduce the need for lengthy maintenance which in turn lowers costly production downtime for the installation.
- Because of its light weight, the coupling does not require intermediate bearing support, which improves cost of ownership for the end-user.

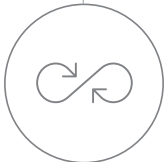

### Strong influence on installation life extension

- The highly advanced composite materials that constitute the ESCODISC FIL coupling confer multiple features (e.g. light weight, low coefficient of thermal expansion) that help reduce vibrations and the load on bearings by up to 80%.



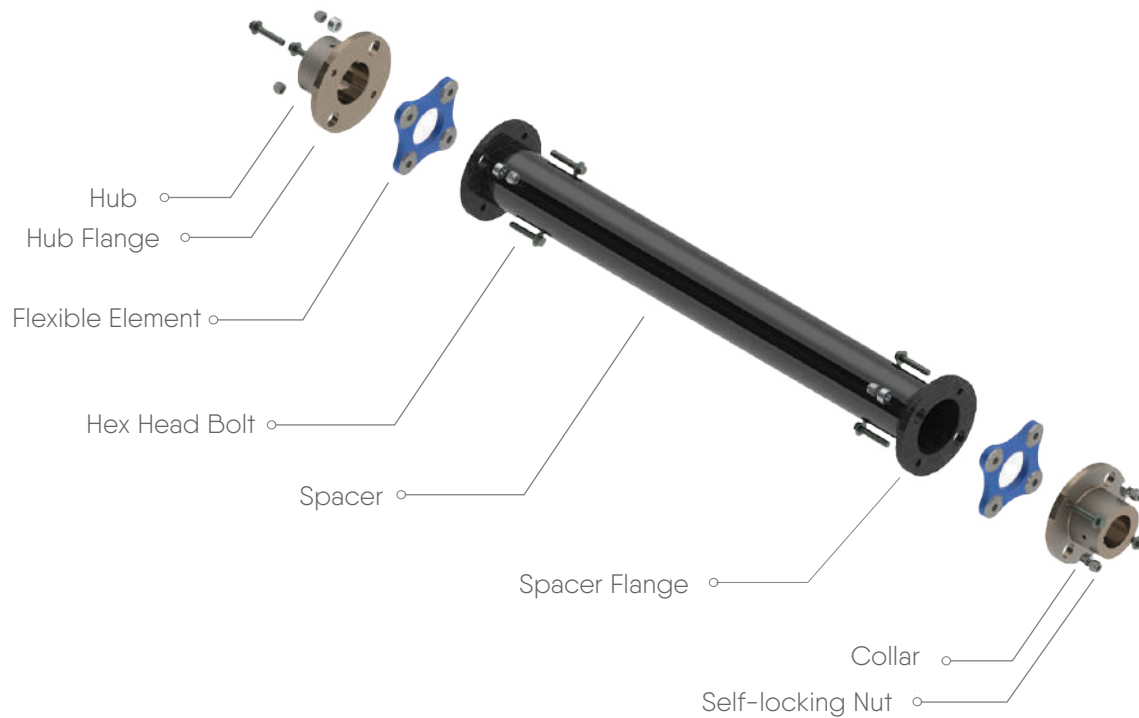

### Marine grade stainless steel

The hubs, along with the fasteners, are made out of marine grade stainless steel (316) in order to provide increased protection against corrosion in aggressive environments.

### Composite spacer

The floating spacer is built from carbon or glass (e-glass) fibres. This composite material is ingrained into an epoxy matrix. A carbon black additive is supplemented to the epoxy resin to provide ultra violet protection.

### Composite disk packs

The flexible elements are made from advanced high-strength composite disc-links and steel bushings, encapsulated in polyurethane. The combination of links and bushings into an aggregated single flexible element provides for improved handling and installation. Unitized elements also eliminates the risk of fretting corrosion. The high strength of the composite material ensures an extended life of the assembly at rated torque and misalignment values. The links come in 5 different sizes (for power ranging 75kW to 675 kW) and can accommodate for 1° misalignment per flexible element.

### Composite flanges

The spacer flange is entirely made out of composite material and its interface with the spacer has been developed to maximize the longevity of the coupling. Poor design of this interface is indeed a common cause for failure of composite couplings. During the ESCODISC FIL DFCT design and testing phase, ESCO put a special focus in optimizing the spacer-flange interface.

## How to select the right coupling size

### Coupling size selection

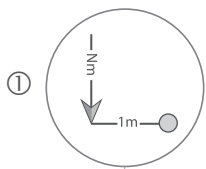

Select the size of ESCODISC FIL coupling that has the required torque capacity by comparing the figure in Technical Data table on following pages ,torque nominal Tn' with the figure obtained through to the following formula:

$T \text{ (Nm)} = 9\,550 \cdot p \cdot F_u / n$ , with:

a. p, power in Kw; b. n, speed in rpm; c.  $F_u$ , safety factor, (dependant on the application, usually 2 for cooling tower applications)

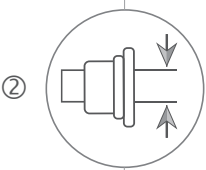

Make sure this coupling will accommodate the largest shaft diameter in Technical Data table on following pages ,size' & ,Max. bore Ød'.

The coupling selected following ② must have an equal or greater torque capacity than the torque figure provided by equation ①. Should it not be the case, please select a coupling of a larger size from Technical Data table on following pages.

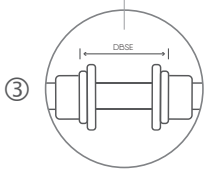

For the selected coupling size, identify in Technical Data table on following pages the first spacer shaft type for which maximum Shaft End Separation ,Max G' exceeds the required DBSE (G) for the application (often referred to as DBSE, distance between shaft ends). The coupling model will be designated by the combination of its max diameter and shaft type (e.g. 73 M3).

Example:

Motor Power: 50kW | Motor Speed: 1 500rpm | Service Factor: 2 (for Cooling Tower)

$$T = 9\,550 \cdot 50 \cdot 2 / 1\,500 = 764 \text{ Nm}$$

In ,torque nominal Tn' compare the obtained value 764 to the maximum continues torque ratings to find the first size that equals or exceeds this value. In this case the selection is E150.

### Assembly weight

The weight of the total assembly is the sum of the shaft weight at minimum DBSE (G) and the weight of the remaining length of the shaft.

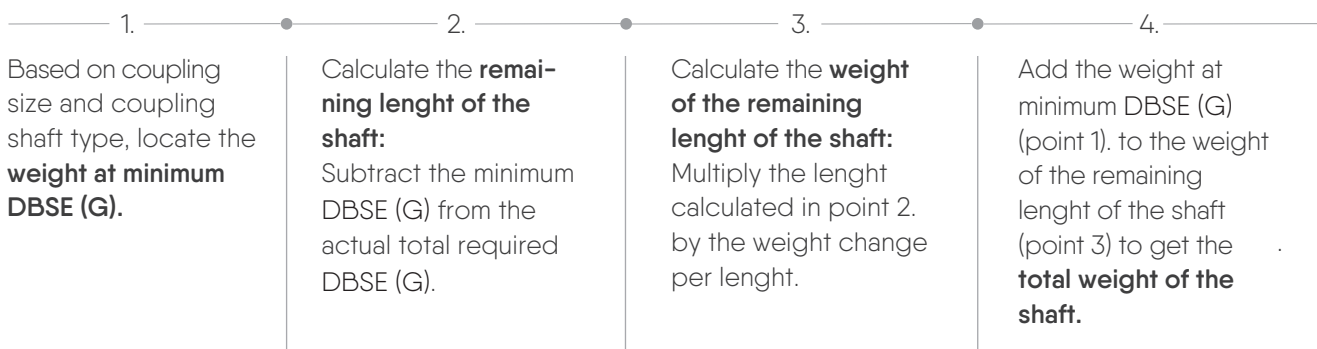

### Assembly inertia

Apply the same method then for the calculation of the weight of the assembly but use the inertia at minimum DBSE (G) ( $Wr^2@ \text{Min. DBSE (G)}$ ) and the inertia changes per length instead of the weight (changes).

### Floating spacer shaft critical speed

The critical speed of the floating spacer shaft can be determined from the chart below. Once you know the spacer shaft designation (i.e. L4) and the DBSE (G) you can plot the point on the chart to determine the critical speed. For example, if the DBSE (G) is 3 m and spacer shaft is L4 find the intersection of x axis at 3 m with the curve of L4 and read the critical speed on the y axis. In this example the value is 3 100 cycles per minutes.

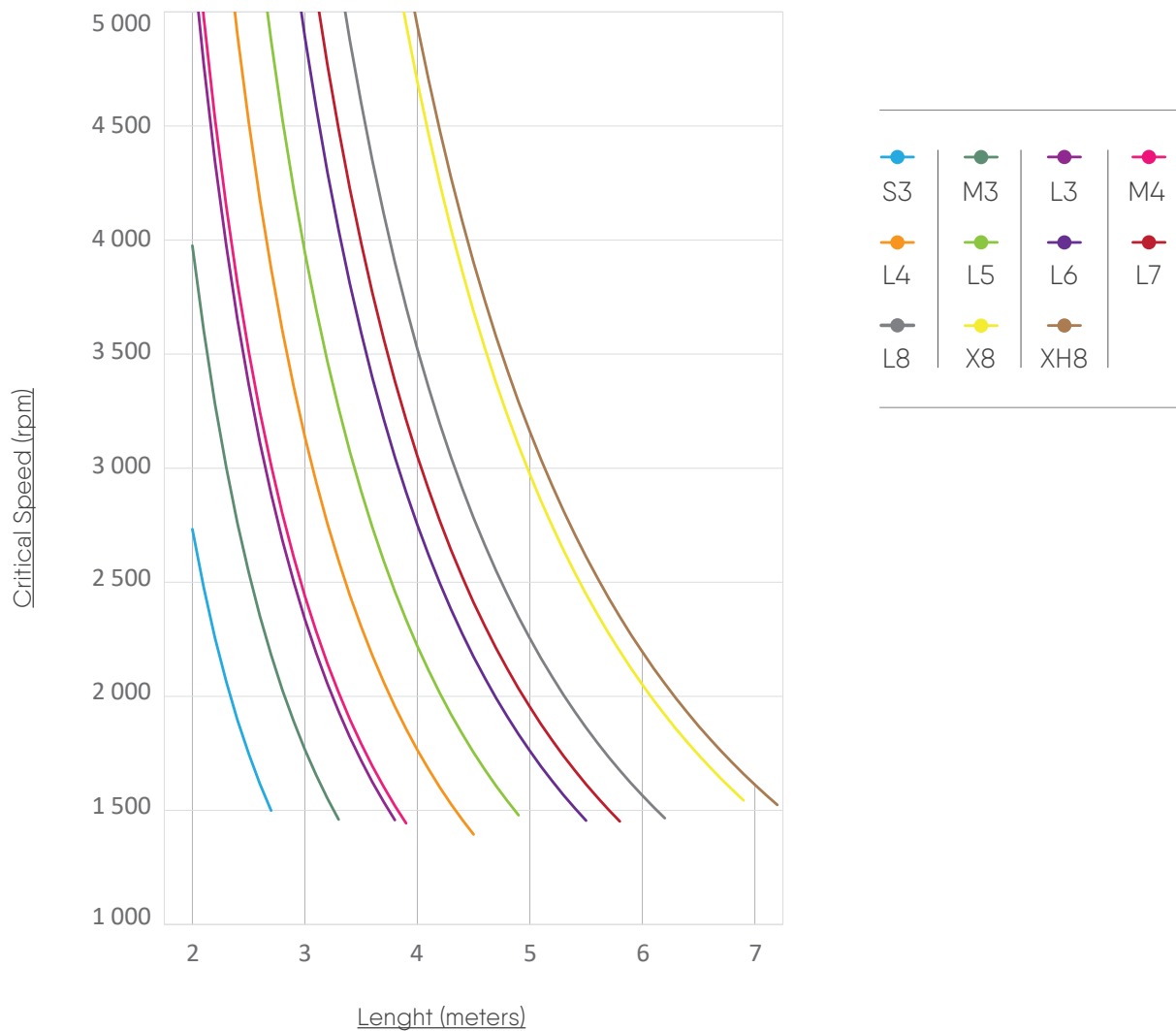

*To be in line with guidelines of Cooling Tower Technology Institute, add an additional safety factor of 1.3 to determine the critical speed.*

FIL  
**STANDARD**  
 E75 ➤ E675

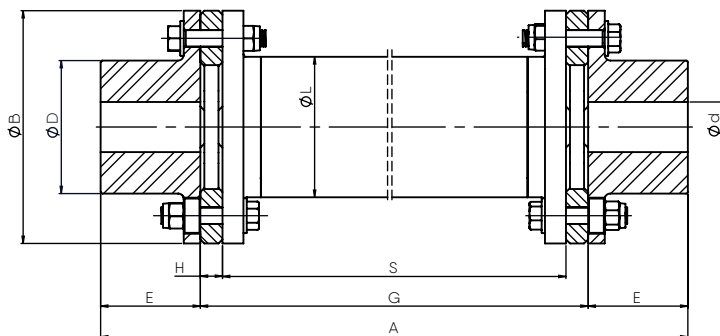
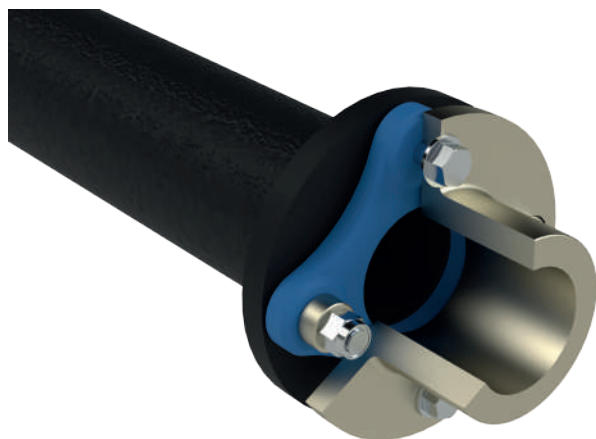

ESCODISC FIL SS

size	torque		standard hub (S)		extended hub (E)		A (3)	$\varnothing B$	$\varnothing D$	$\varnothing D1$	E standard hub	E1 extended hub
	nominal Tn	peak Tp	min. bore $\varnothing d$ min. (1)	max. bore $\varnothing d$ max. (2)	min. bore $\varnothing d1$ min. (1)	max. bore $\varnothing d1$ max. (2)						
FIL	kNm	kNm	dimensions in mm									
E75	0.40	0.80	0	54	-	-	343.3	133.35	74.40	-	57.15	-
E150	0.80	1.63	0	54	50	73	343.3	133.35	76.20	101.60	57.15	57.15
E225	1.22	2.44	0	73	70	101	464	178.56	98.55	142.24	79.50	88.90
E300	1.63	3.25	0	75	70	101	464	178.56	111.25	142.24	79.50	88.90
E675	3.67	7.34	0	106	60	130	546.5	241.30	139.70	196.85	95.30	95.25

- (1) Min. finish bore diameter
- (2) Max. bore diameter with one keyway acc. DIN 6885/1
- (3) Total length with 2 standard hubs. For extended hubs,  $A-2xE+2xE1$
- (4) For prebored standard hubs
- (5) For 1 extended hub, total weight + "x"

size	"X" increase in weight
	kg
E75	-
E150	0.1
E225	1.9
E300	0.7
E675	5.6

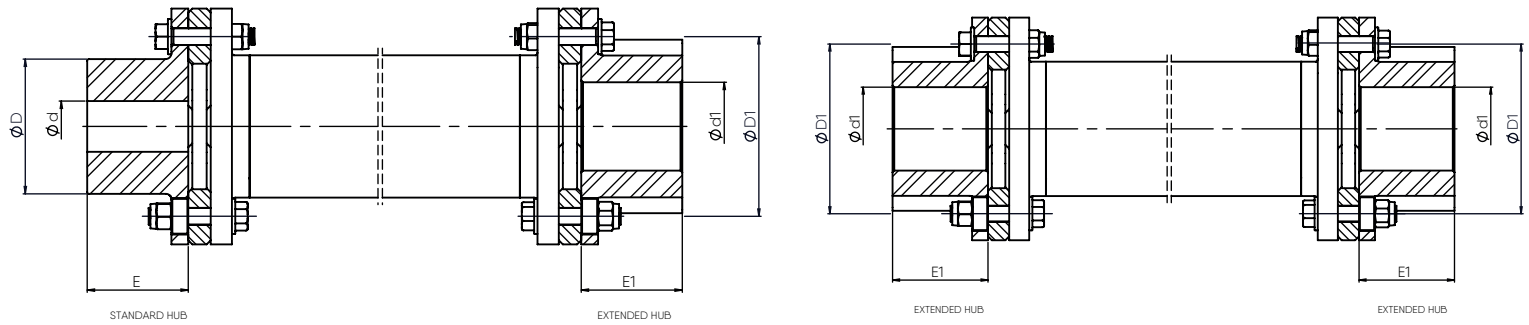

ESCODISC FIL SE

ESCODISC FIL EE

G min.	H	max. misalignment axial	spacer shaft material	spacer OD ØL	G max.		A max.		weight @G min. (4)(5)	inertia @G min. (4)(5)	weight change per meter length	inertia change per meter length
					@ 1 500 rpm	@ 1 800 rpm	@ 1 500 rpm	@ 1 800 rpm				
					rpm				kg	kgm <sup>2</sup>	kg/m	kgm <sup>2</sup>
229	12.7	0.75	S3	81	2 330	2 050	2 444	2 164	5.9	0.010	1.875	0.0025
			M3	81	2 794	2 540	2 908	2 654	5.89	0.010	1.58	0.0021
229	12.7	0.75	S3	81	2 330	2 050	2 444	2 164	5.26	0.009	1.875	0.0025
			M3	81	2 794	2 540	2 908	2 654	5.2	0.009	1.58	0.0021
305	16	1	L3	81	3 125	2 870	3 239	2 984	5.12	0.009	1.125	0.0015
			M4	108	3 327	3 022	3 486	3 181	14.2	0.0392	2.75	0.0076
			L4	108	3 784	3 454	3 943	3 613	14	0.0386	1.96	0.0054
			L5	135	4 267	3 886	4 426	4 045	16.2	0.0474	2.4	0.01
305	19	1	L6	160	4 673	4 267	4 832	4 426	18.8	0.0626	2.9	0.017
			L4	108	3 784	3 454	3 943	3 613	16.2	0.0386	1.96	0.0054
			L5	135	4 267	3 886	4 426	4 045	18.4	0.0474	2.4	0.01
356	19	1.25	L6	160	4 673	4 267	4 864	4 458	31.5	0.18	2.9	0.017
			L7	186	5 029	4 597	5 220	4 788	35.3	0.21	3.37	0.027
			L8	211	5 359	4 902	5 550	5 093	39.6	0.26	3.8	0.041
			X8	211	5 892	5 384	6 083	5 575	39.6	0.26	3.8	0.041
			XH8	211	6 299	5 740	6 490	5 931	39.6	0.26	3.8	0.041

- Couplings can be supplied with several options (e.g. puller holes, set screws)
- For the correct coupling selection please refer to page 12 et seqq. (B113a)
- For special executions or requirements, please contact us
- Technical modifications reserved and given values without engagement

# Installation and maintenance

## ESCODISC FIL series

### 1) Introduction

Coupling must be selected properly according to selection chart (B113a).

These documents are available in coupling catalogue ESCODISC FIL or on our web site «www.escocoupling.com».

In case of any change or adaptation not performed by ESCO on the coupling, it is customer responsibility to size and manufacture it properly to guarantee safe torque transmission and absence of unbalance that could affect the life of the coupling and the connected machines.

It is customer responsibility to make sure that shaft and key material, size and tolerance suit the application. Maximum bore capacity is given in the catalogue.

If key assembly is not calculated and machined by ESCO, it is customer responsibility to make sure that hub length, bore size and machining tolerances will transmit the torque.

If interference fit is not calculated and machined by ESCO, it is customer responsibility to make sure that interference and machining tolerances will transmit the torque and not exceed hub material permissible stress.

It is customer responsibility to protect the coupling by e.g., a coupling guard and to comply with the local safety rules regarding the protection of rotating parts.

### 3) Assembly FIL couplings

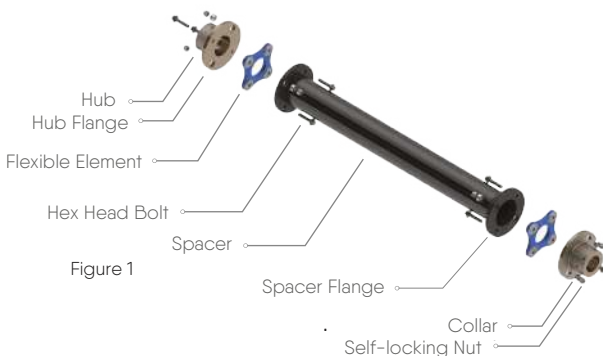

#### 3.1. Preparation

- 3.1.1. Clean both shafts and remove any burrs.
- 3.1.2. The Shaft end separation SES for the application to be verified. Check the same in the product drawing provided with the unit before starting.
- 3.1.3. The hubs, flexible element and the spacer-sub assembly are assembled and supplied.
- 3.1.4. Remove the bolts that connect hubs to flexible element & Spacer, dismantle all the parts.
- 3.1.5. The nuts supplied with the system have a nylon locking feature. All the hardware's used are made of stainless

### 2) Assembly preparation

Disassemble the coupling and ensure the conformity of the supplied equipment.

- Verify coupling size and conformity (see catalogue or website)
- Identify any damaged or missing parts.
- Verify conformity of the coupling/machine interfaces

Coupling original protection allows for storage:

- Indoors dry: 18 months
- Indoors humid: 12 months
- Outdoors covered: 9 months
- Outdoors open: 3 months

For longer periods, it is customer responsibility to protect the parts properly.

Instructions are a part of the supply of the coupling. Be sure valid and complete assembly, operation and maintenance instructions are available. Make sure they are well understood. In case of doubt, refer to ESCO. Assembly, disassembly, and maintenance must be performed by qualified, trained and competent fitters.

Before starting with assembly, disassembly, and maintenance, verify the availability of the tooling necessary

- To manipulate the parts
- To assemble the interfaces
- To align the coupling
- To tighten the screws and nuts

steel. The tightening torque required is based on that material and care should be taken not to pre-stress the bolts beyond that limit.

- 3.1.6. Verify proper fits between hubs and equipment shafts before proceeding further.
- 3.1.7. Match marking the assembly is not necessary to maintain dynamic balance. Do not punch or scar the spacer flanges in any way. Use grease pencil, paint pen or other non-destructive methods to mark the reference point for alignment purpose.
- 3.1.8. The coupling system is designed so that the flexible elements and/or the floating centre shaft may be removed without moving the connected equipment or hubs. Proper installation will ensure this feature is maintained for future convenience when replacing flexible elements or hardware.
- 3.1.9. Align the machine shafts using an indicator. Check alignment properly.
- 3.1.10. Ensure that the face of hubs, flexible element & and spacer are perfectly degreased.

3.2. Coupling assembly

- 3.2.1. Ensure that the parts are clean and then mount the hub in the correct position on the shaft. Hub flange face must be flushed with shaft end. Apply Loctite 242 to the set screws and lock in place.
- 3.2.2. Slide the other hub on the shaft and insert the set screws. Do not tighten the set screws since the hub needs to be re-positioned and aligned. Refer figure 4.
- 3.2.3. Make sure spacer to be supported properly during assembly.
- 3.2.4. Fix the flexible element on one side of the spacer with three bolts. (See figure 5)
- 3.2.5. Align the bolts of spacer with the large holes in the hub and slide it in position.
- 3.2.6. Insert the bolts with overload washer installed, through the small holes in the hubs and flexible element. Insert the self-locking nuts and hand tighten it just to hold the spacer in place.
- 3.2.7. On the other side, Slide the flexible element in between shaft and spacer.

- 3.2.8. Slide the other hub towards the flexible element by matching the large holes and flush the hub flange face with the shaft end. Insert the bolts through the small holes in the hubs and flexible element. Insert the self-locking nuts and hand tighten it just to hold the spacer in place.
- 3.2.9. Tighten the fit bolts and nuts on both hubs and spacer flange.

size	tightening torque (Nm)
E75	47.45
E150	47.45
E225	61
E300	61
E675	81.34

Table 1

- 3.2.10. Use torque wrench on the nut and not on the bolt. Care should be taken while tightening the nut. Refer the above table 1 for tightening torques.

3.3. Alignment verification

Alignment is measured as shown on the figure 2 (Angular alignment) & 3 (Axial alignment).

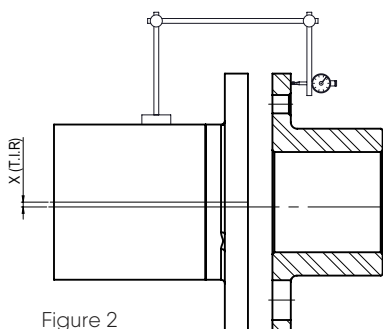

Figure 2

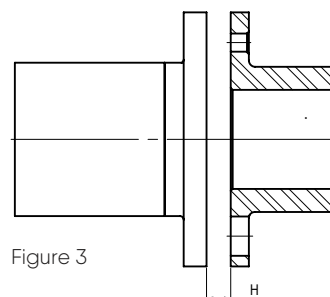

Figure 3

3.3.1. Angular alignment

- 3.3.2. Mount a dial indicator on the floating shaft (spacer) and indicate the face of hub flange (See figure 2)
- 3.3.3. Set the dial indicator to zero then rotate the shaft 360° and record the maximum and minimum reading on dial indicator.
- 3.3.4. The range of reading obtained should not exceed the values given in the table below.
- 3.3.5. If the range exceeds the values given in table 2, then the setup must be re-aligned to obtain the values. This will provide maximum life of the flexible element and connected parts.

3.4.1. Axial misalignment

- 3.4.2. Axial misalignment must be checked to normalize the spring position of flexible element.
- 3.4.3. To check the axial misalignment, the space between the hub and spacer flange must be measured by using a caliper.
- 3.4.4. Record the reading for 4 intervals at 90° and calculate the average of the same.
- 3.4.5. The average should not exceed the range mentioned in table 3.
- 3.4.5. After the alignment remove the set screws from the hub and apply Loctite 242 and lock them in place.

size	recommended range (X-TIR) (mm)
E75	0.254
E150	0.254
E225	0.508
E300	0.508
E675	0.508

Table 2

size	nominal space b/w flanges (mm)	spacer range (H) (mm)
E75	12.7	12.44 - 12.95
E150	12.7	12.44 - 12.95
E225	15.875	15.36 - 16.38
E300	19.05	18.54 - 19.56
E675	19.05	18.54 - 19.56

Table 3

#### 4) Warnings

Before removing the coupling-guard and proceeding with any assembly, operation, or maintenance operation of the coupling, make sure the complete system is completely shut down and definitively disengaged from any possible source of rotation due to electrical power supply or any loss of braking effect.

Make sure everyone attending the equipment area will be properly informed (for example by means of warnings properly located) about the maintenance or assembly situation.

#### 5) Operation and maintenance

##### 5.1. Operation

During the first running hours, and then regularly,

- 5.1.1. Check for any noise and vibration, loss of part.
- 5.1.2. Verify the alignment of the screws and tightening torques of the screws.

##### 5.2. Maintenance

- 5.2.1. Every 6 000 hours or every 12 month  
Visual Inspection of flexible element for any fatigue crack and verify alignment.  
Unmounting of coupling is not needed.
- 5.2.2. Every 12 000 hours or every 24 month  
Disassemble and inspect coupling as described in §7.  
Coupling should be dis-assembled only in case of occurring fatigue cracks or damage in flexible element.

#### 6) Disassembly and inspection

##### 6.1. Disassembly

- 6.1.1. Give a proper support to floating shaft before removing the fit bolts and nuts.
- 6.1.2. Remove the fit bolts and nuts connecting hubs & flexible element.
- 6.1.3. Remove set screw and slide the hub slowly away from the spacer flange.
- 6.1.4. Do the same on the other side and remove the spacer assembly.

##### 6.2. Inspection

- 6.2.1. Clean all the parts.
- 6.2.2. Visually inspect the flexible element for any fatigue crack. .

##### 6.3. Parts to replace

- 6.3.1. In case of damage, complete flexible element must be replaced.

#### 7) Assembly reference

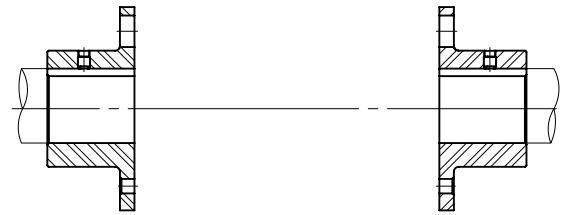

Figure 4

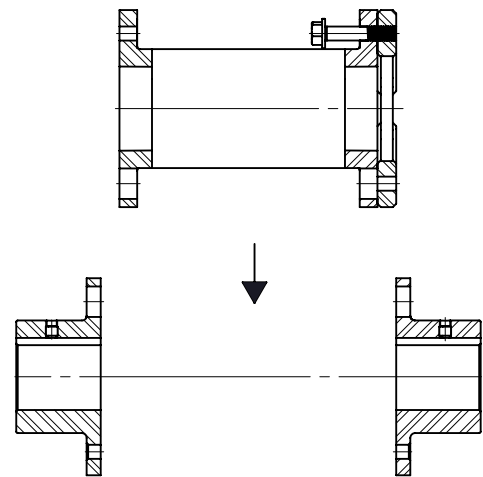

Figure 5

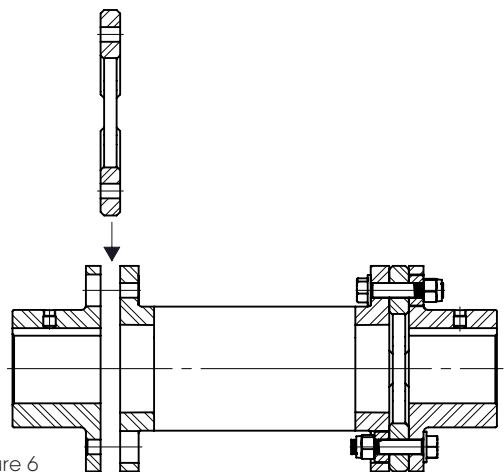

Figure 6

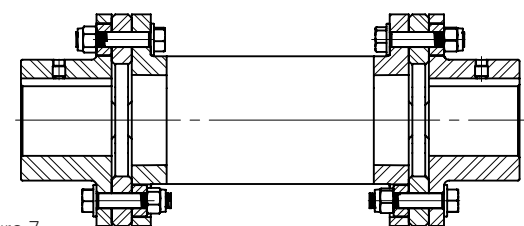
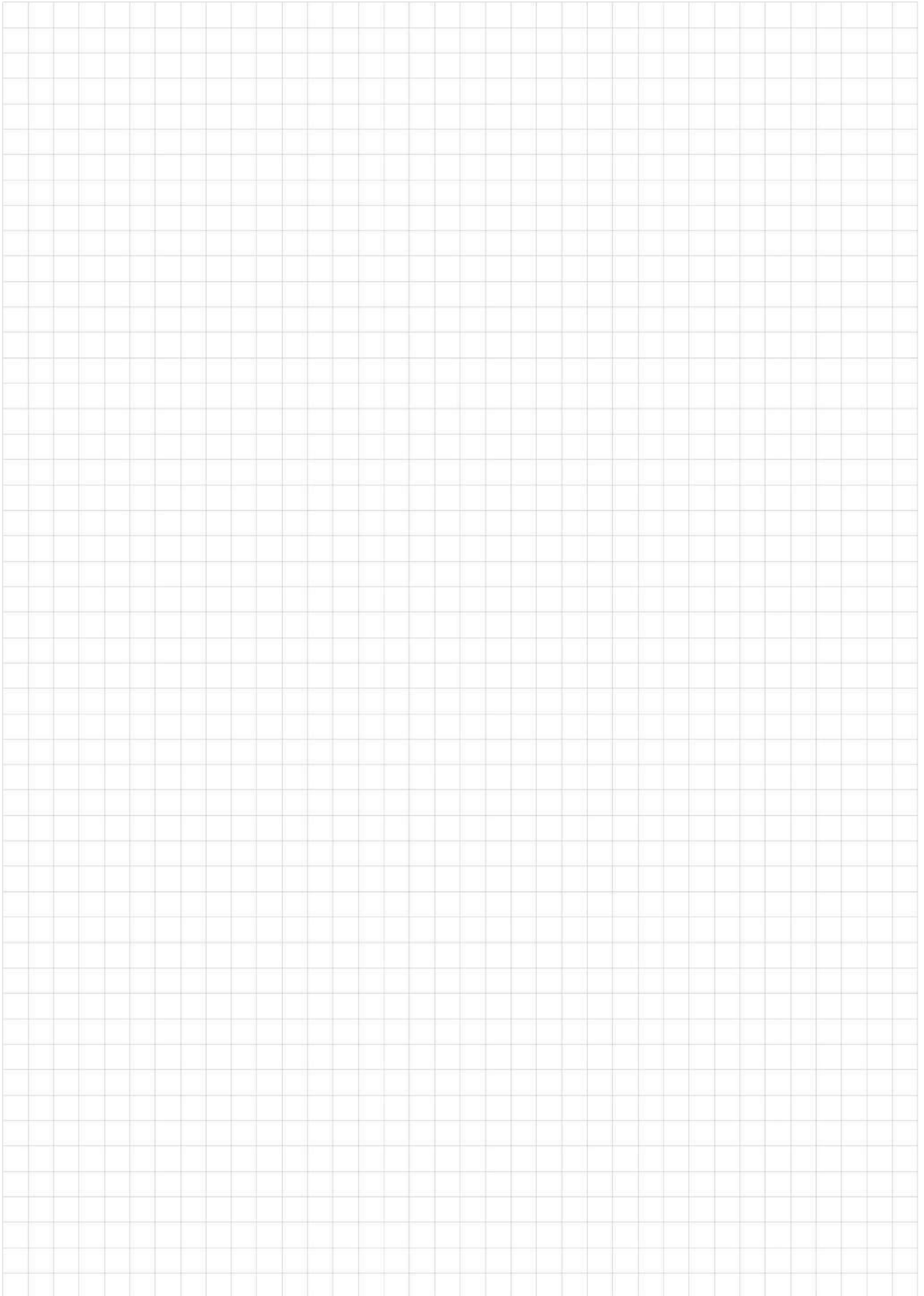

Figure 7

Notes:





# ESCO worldwide

## ESCO Couplings SRL

Avenue Ernest Solvay, 48

B - 1480 Saintes

Belgium

Tel + 32 (0) 2 715 65 60

Fax + 32 (0) 2 720 83 62

e-mail: [info@esco-couplings.be](mailto:info@esco-couplings.be)

website: [www.escogroup.com](http://www.escogroup.com)



## ESCO Couplings & Transmissions Pvt. Ltd.

Plot No. 69-D

Bengaluru Aerospace Park

Unachuru Village Jala Hobli

Bengaluru

India

Tel +91 80 7100 1800

e-mail: [info@esco-couplings.co.in](mailto:info@esco-couplings.co.in)

website: [www.escogroup.com](http://www.escogroup.com)

## Local Contact

Authorised distributor



TYMA CZ, s.r.o.

Na Pískách 731/12

CZ - 40004 Trmice, Czech Republic

Phone: +420 475 655 010

Email: [info@tyma.cz](mailto:info@tyma.cz)

[www.tyma.cz](http://www.tyma.cz)

Version 01-2025