



ENGINEERING

Manual

Innovative
Belt & Chain solutions
for every industry
& application

Engineering Manual

Innovative Belt and Chain solutions for
every industry & application

Section 1

| | |
|---------------------------|----------|
| Introduction | 7 |
|---------------------------|----------|

Section 2

| | |
|--|----------|
| Belt and Chain Selection | |
| Belt and Chain System Selection Process | 8 |
| Belt System Surface Options | 9 |

Section 3

| | |
|--|-----------|
| Design Guidelines | |
| Basic Factors affecting Belt/Chain Lifetime | 14 |
| Environmental Considerations | 14 |
| Warnings | 15 |
| Basic Conveyor Requirements and Considerations | 16 |
| Dimension definitions | 17 |
| Drive Concept | 18 |
| Shaft Selection | 18 |
| Torsion Loading..... | 18 |
| Aligning the Shafts | 18 |
| Retaining Sprockets | 19 |
| Intermediate Bearings | 19 |
| Rollers as Idle Shafts and Sprocket replacements | 20 |
| Drive Types | 20 |
| Straight running Conveyors | 21 |
| Elevating Conveyors | 21 |
| Incline Conveyor | 21 |
| Sideflexing Conveyors | 24 |
| Sideflexing Chains | 24 |
| Sideflexing Chains, single Track | 24 |
| Sideflexing Chains, multiple Tracks | 24 |
| Sideflexing Modular Belts | 25 |
| Basic L-Shape | 25 |
| How does a sideflexing Belt work | 25 |
| True Pitch in outside Radius..... | 26 |
| Load Line | 26 |
| Reducing overall Dimensions for sideflexing Belt Conveyors | 27 |
| Placing the Drive | 27 |
| Load & Speed Properties | 28 |
| Precautions with Catenary Sags for sideflexing Belts | 28 |
| Mounting of Sprockets | 29 |
| Spiral Conveyors | 30 |

Section 3

| | |
|--|-----------|
| Transfer Guidelines | 31 |
| Side Transfer | 31 |
| Inline Transfer | 31 |
| 90 degree Transfer | 31 |
| End Off/End On | 32 |
| Dead Plates | 32 |
| Finger Plates | 33 |
| Roller Transfer | 33 |
| Special Design Guidelines | 34 |
| Gripper Conveyors | 34 |
| Alpine (Serpentine) Conveyors | 34 |
| Pasteurizers & Blanchers | 35 |
| Vacuum Conveyors | 35 |
| Long Conveyors | 36 |
| Carousel (endless) Conveyors | 37 |
| Thermal Expansion and Contraction..... | 37 |
| Expansion due to Water Absorption..... | 38 |
| Slip Stick/Surging/Pulsation | 38 |
| Chordal Action | 39 |
| Wearstrip and Support | 40 |
| Straight running Chains, single Tracks | 40 |
| Straight running Chains, multiple Tracks | 41 |
| Sideflexing Chains, single Tracks | 42 |
| Sideflexing Chains, multiple Tracks..... | 43 |
| Sideflexing Superflex Chains, open version..... | 44 |
| Sideflexing Superflex Chains, closed version..... | 45 |
| uni Flex Chains | 46 |
| Belt Carryways and Returnways | 47 |
| Tracking & Control Systems for Sideflexing Belt..... | 48 |
| Returning Belt with Product Supports | 50 |
| Anti-sag Carryway Wearstrip Configuration | 50 |
| Take-up Methods | 51 |
| Control of Belt Length | 51 |
| Back Tension | 54 |
| Special Take-up Arrangement | 54 |
| Compressed Belt Take-up | 55 |
| Driving Terminals | 55 |

Section 4

| | |
|--|-----------|
| Materials | |
| Chain and Belt Material Listing and Properties | 56 |
| Plastic Materials, Temperature Range, Load Index and FDA | 56 |
| Steel and Stainless Steel | 57 |
| Plastic materials | 58 |
| Factors | 62 |
| Friction Factors | 62 |
| Temperature Factors..... | 62 |

Section 5

Calculations

| | |
|---|-----------|
| Chain Calculations | 63 |
| Tensile Forces | 63 |
| Temperature and Speed dependent Tensile Force | 63 |
| Conveyor with straight running and sideflexing Chains | 64 |
| Conveyor with Inclination | 65 |
| Serpentine | 66 |
| Belt Calculations | 68 |
| Tensile Forces | 68 |
| Conveyor with Inclination | 69 |
| Reinforcement of Belt Systems | 71 |
| Expansion and Contraction of the Belt | 72 |
| Determining Number of Sprockets for Belt Systems | 72 |
| General Calculations | 74 |
| Catenary Sag | 74 |
| Dimensioning of the Motor | 75 |
| Dimensioning of the Shaft (Steel) | 76 |
| Control of Shaft Deflection of the Shaft under Stress | 78 |

Section 6

Installation, Maintenance and Troubleshooting

| | |
|--|-----------|
| Installation Guidelines | 80 |
| Maintenance Guidelines | 80 |
| Replacement of Conveyor Parts | 80 |
| Cleaning Guidelines | 81 |
| Troubleshooting Guidelines | 82 |

Section 7

Appendix

| | |
|---|------------|
| Conveyors with Turn Discs | 94 |
| Conversion of Units (metric/imperial) | 96 |
| Calculation Factors | 97 |
| Load-Speed Relations | 100 |
| Temperature Factors | 103 |
| Belt Elasticity | 104 |
| Glossary | 106 |
| Chemical Resistance Chart | 112 |
| Technical Data Sheet for Belt/Chains Applications (metric) | 137 |
| Technical Data Sheet for Belt/Chains Applications (imperial) | 139 |



The uni-chains product range offers the world's largest product range of innovative and flexible conveyor chains and belts.

The uni-chains product range builds on the development and manufacturing of

- Slat Top chains in steel and plastic
- Crate chains for heavy loads
- Plastic chains with molded inserts
- Belts in many variations, which can be assembled into wide flat belts with various accessories to meet the application need
- Chains and belts in special materials
- Chain and belt sprockets in various materials

This manual offers to instruct the user how to properly select a uni-chains product for an application and how to properly apply the uni-chains product in the design and fabrication of the conveyor. The uni-chains product line is divided into two separate groups: uni Slat Top Chains and uni Plastic Modular Belts. In general, chains are molded in certain widths and have one hinge with a SS pin that pulls the load.

Belts, on the other hand, can be built out of small pieces in a "brick-lay" type pattern to achieve basically any width. Belts have many hinges that pull the load and, therefore, a belt gets stronger as it gets wider. Since there are some inherent differences between the two, certain sections of this manual will be specific to one type or the other. These sections will be specifically noted.

Belt and Chain System Selection Process

Many factors must be considered when selecting a belt or chain for an application. It may be helpful to remember the acronym PPLESC as a guide to which information is important. PPLESC stands for Product, Process, Layout, Environment, Standards and Commercial Factors. With this information you can make an informed belt or chain selection for your application. Some details on these are shown below:

Product

- Weight
- Size
- Shape
- Structure
- Product Temperature

Process

- Required speed
- Accumulation of the products
- Heating
- Cooling
- Washing
- Drying
- Temperature
- How are the products loaded on to the belt (Pushed sideways? Dropped from above?)
- Sideways product movements on the belt

Layout

- Inclining/declining
- Straight running
- Sideflexing
- Twisting
- Required width
- Transfer zones
- Physical space for installation
- Length of sections
- If sideflexing: Radius in the curves and the angle of the curve

Environment

- Surrounding temperature
- Chemicals (e.g. acid, cleaning agents)
- Abrasive elements dust/sand/glass
- Water/Humidity

Standards

- FDA or similar approval needed on the material (Food contact)
- USDA Meat and Poultry Approval needed
- USDA Dairy approval needed
- NSF Approval needed

Commercial factors

- Most cost effective product for the job
- Desired lifetime
- Acceptable pricing level to the customer

Once you have the above information you can use it to select the proper belt. First, choose the right type of chain or belt – straight running or sideflexing. All uni-chains belts and chains can be used in straight running applications. However if the conveyor must sideflex the designer must be sure to select a sideflexing belt or chain.

Next, select the pitch of the belt. Pitch is the most defining characteristic of a belt or chain. Smaller pitch reduces chordal action and vibration, has less noise, can achieve tighter transfers and use smaller sprockets. Larger pitch belts are usually stronger and thicker for more wear and impact resistance.

Surface should also be considered. uni-chains offers many surface openings, textures and accessories to suit every application. This includes the design of the underside of the belt or chain which can be important when considering cleaning, wear or support. The choice of a chain or belt for your application will depend on which has the available surface, top and bottom that are needed in your application. On the next page you will find some examples of top and bottom surface designs that are available.

The track system should also be considered (especially with uni Slat Top Chain) as the uni-chains product range is composed of both tabbed and non-tabbed belts and chains. This is especially important on the return side of the conveyor as this requires different methods of support.

The drive method should also be considered. There are different types of drive configurations depending on space limits or on conveyor function. The uni-chains product range offers both conventional sprocket driven systems as well as horizontal sprocket drive systems for race track/endsless designs or multi-tier drive applications.

Next, choose the right material for your application. Choice of material is dependent on many factors including among others strength, wear resistance, chemical resistance, temperature limits, impact, speed and agency approvals. In general, uni-chains belts are offered in three standard materials: PP, PE, Acetal (POM), and our chains are offered in several grades of Acetal (POM). Refer to the material section for more information on selecting the proper material (pages 56-62).

Finally, select a belt or chain of sufficient strength for your application. After going through the process above, ensure that the chain or belt is strong enough to pull the desired load. See the calculation section to determine this or contact uni-chains engineering for assistance. It may be a case where the designer must choose a stronger material or a larger pitch belt after getting to this step. You may need to go through these steps multiple times to arrive at the best solution.

Belt System Surface Options

| Openings | Surfaces | | | | | | | | |
|----------|---|------|----------|---|-----------------------|------------|-----------|---|---------|
| | Flat | Grip | No Cling | Reduced Contact | Rib Top | Roller Top | Rough Top | Rubber Top | V-style |
| 34% | uni SNB M2 | | | uni SNB M2 34% | uni SNB M2 34% Rib | | | | |
| 36% | uni OPB 4V | | | uni L-SNB | uni L-SNB Rib | | | | |
| 37% | uni M-TTB | | | uni M-TTB CS | | | | | |
| 40% | | | | uni M-PNB M1 | | | | | |
| 43% | uni Flex ASB uni Flex ASB T | | | uni Flex ASB CS uni Flex ASB CS T | | | | | |
| 47% | uni Flex SNB C uni Flex SNB CR uni Flex L-ASB uni Flex L-ASB R uni Flex L-ASB T | | | | | | | uni Flex SNB CR Rubber Top uni Flex SNB C Rubber Top | |
| 55% | | | | uni Flex SNB L uni Flex SNB W uni Flex SNB WT uni Flex SNB WO | | | | | |
| 66% | | | | uni OWL | | | | | |
| Vacuum | uni M-QNB Vacuum | | | | | | | | |

Belt System Surface Options

Flat Surface



uni M-QNB
Pitch 12.7 mm (0.50 in.)
Surface opening 0%



uni Light
Pitch 19.05 mm (0.75 in.)
Surface opening 0%



uni Light
Pitch 19.05 mm (0.75 in.)
Surface opening 10%



uni M-SNB M3
Pitch 12.7 mm (0.50 in.)
Surface opening 14%

Belt System Surface Options

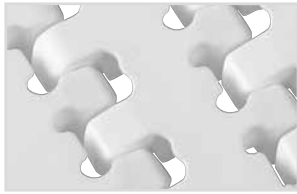

uni Flex ONE
Pitch 38.1 mm (1.50 in.)
Surface opening 16%

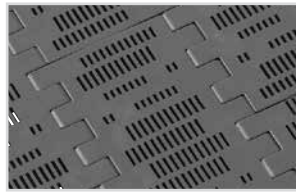

uni BLB
Pitch 50.8 mm (2.00 in.)
Surface opening 18%

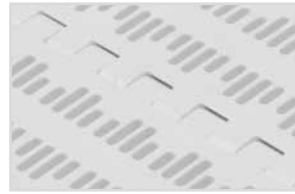

uni MPB
Pitch 50.8 mm (2.00 in.)
Surface opening 18%

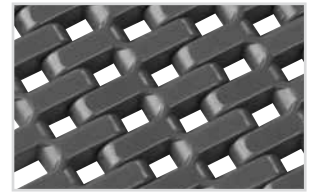

uni SNB M2
Pitch 25.4 mm (1.00 in.)
Surface opening 20%



uni CNB
Pitch 25.4 mm (1.00 in.)
Surface opening 22%



uni SSB
Pitch 38.1 mm (1.50 in.)
Surface opening 32%



uni M-TTB
Pitch 38.1 mm (1.50 in.)
Surface opening 37%



uni Flex ASB
Pitch 25.4 mm (1.00 in.)
Surface opening 47%

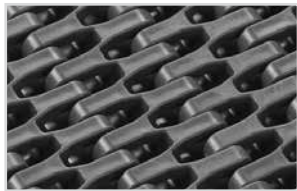

uni Flex SNB CR
Pitch 25.4 mm (1.00 in.)
Surface opening 47%

Grip Surface



uni MPB G
Pitch 50.8 mm (2.00 in.)
Surface opening 0%



uni MPB GE
Pitch 50.8 mm (2.00 in.)
Surface opening 0%

No Cling Surface



uni S-MPB N
Pitch 25.4 mm (1.00 in.)
Surface opening 0%



uni S-MPB NE
Pitch 25.4 mm (1.00 in.)
Surface opening 0%



uni MPB N
Pitch 50.8 mm (2.00 in.)
Surface opening 0%



uni MPB NE
Pitch 50.8 mm (2.00 in.)
Surface opening 0%

Belt System Surface Options

Reduced Contact Surface



uni L-SNB
Pitch 50.0 mm (1.97 in.)
Surface opening 36%

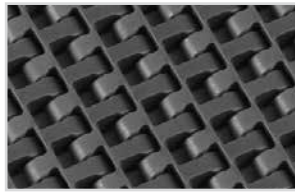

uni M-TTB CS
Pitch 12.7 mm (0.50 in.)
Surface opening 37%

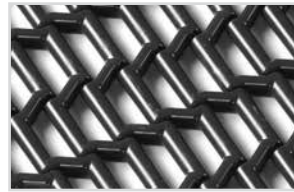

uni M-PNB M1
Pitch 12.7 mm (0.50 in.)
Surface opening 40%



uni Flex ASB CS
Pitch 25.4 mm (1.00 in.)
Surface opening 43%

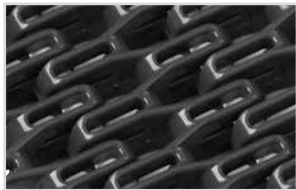

uni Flex SNB L
Pitch 25.4 mm (1.00 in.)
Surface opening 55%

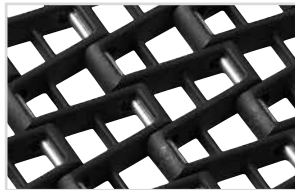

uni OWL
Pitch 27.9 mm (1.10 in.)
Surface opening 66%

Rib Top Surface

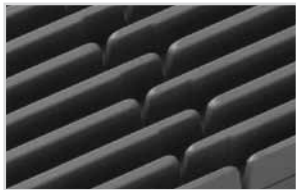

uni OPB 4V Rib
Pitch 50.0 mm (1.97 in.)
Surface opening 23%

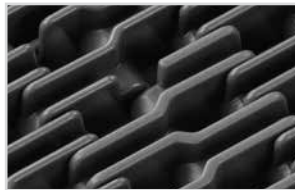

uni SNB M2 Rib
Pitch 25.4 mm (1.00 in.)
Surface opening 34%

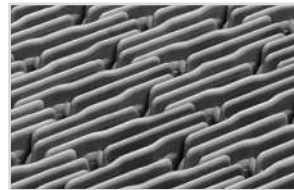

uni L-SNB Rib
Pitch 50.0 mm (1.97 in.)
Surface opening 37%

Roller Top Surface



uni RTB M1
Pitch 50.8 mm (2.00 in.)
Surface opening 0%

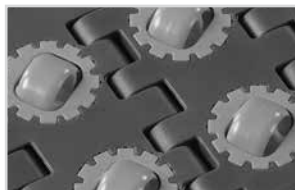

uni RTB M2
Pitch 50.8 mm (2.00 in.)
Surface opening 0%



uni RTB M2 Rubber
Pitch 50.8 mm (2.00 in.)
Surface opening 0%



uni MPB RO
Pitch 50.8 mm (2.00 in.)
Surface opening 16%



uni MPB PRR
Pitch 50.8 mm (2.00 in.)
Surface opening 22%

Belt System Surface Options

Rough Top



uni CPB Rough
Pitch 50.8 mm (2.00 in.)
Surface opening 0%



uni XLB Rough
Pitch 63.5 mm (2.50 in.)
Surface opening 0%



uni XLB 15% Rough
Pitch 63.5 mm (2.50 in.)
Surface opening 15%



uni CPB Rough
Pitch 50.8 mm (2.00 in.)
Surface opening 20%

Rubber Top



uni M-QNB Rubber Top
Pitch 12.7 mm (0.50 in.)
Surface opening 0%

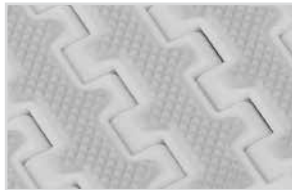

uni Light Rough Rubber Top
Pitch 19.05 mm (0.75 in.)
Surface opening 0%

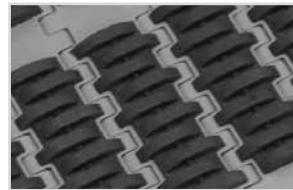

uni QNB Rubber Top
Pitch 25.4 mm (1.00 in.)
Surface opening 0%



uni CPB Rubber Top - RB1
Pitch 50.8 mm (2.00 in.)
Surface opening 0%



uni CPB Rubber Top - RB2
Pitch 50.8 mm (2.00 in.)
Surface opening 0%



uni MPB Rubber Top
Pitch 50.8 mm (2.00 in.)
Surface opening 0%



uni SNB M2 Rubber Top
Pitch 25.4 mm (1.00 in.)
Surface opening 20%

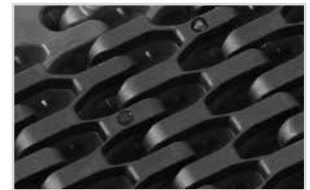

uni Flex SNB CR Rubber Top
Pitch 25.4 mm (1.00 in.)
Surface opening 47%

V-Style



uni XLB M2 V8
Pitch 63.5 mm (2.50 in.)
Surface opening 0%

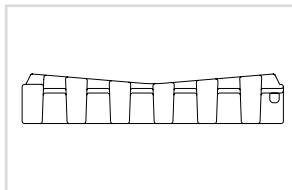

uni XLB M2 V8
Pitch 63.5 mm (2.50 in.)
Surface opening 0%

Vacuum



uni M-QNB Vacuum
Pitch 12.7 mm (0.50 in.)
Surface opening 0%

Basic Factors affecting Belt/Chain Lifetime

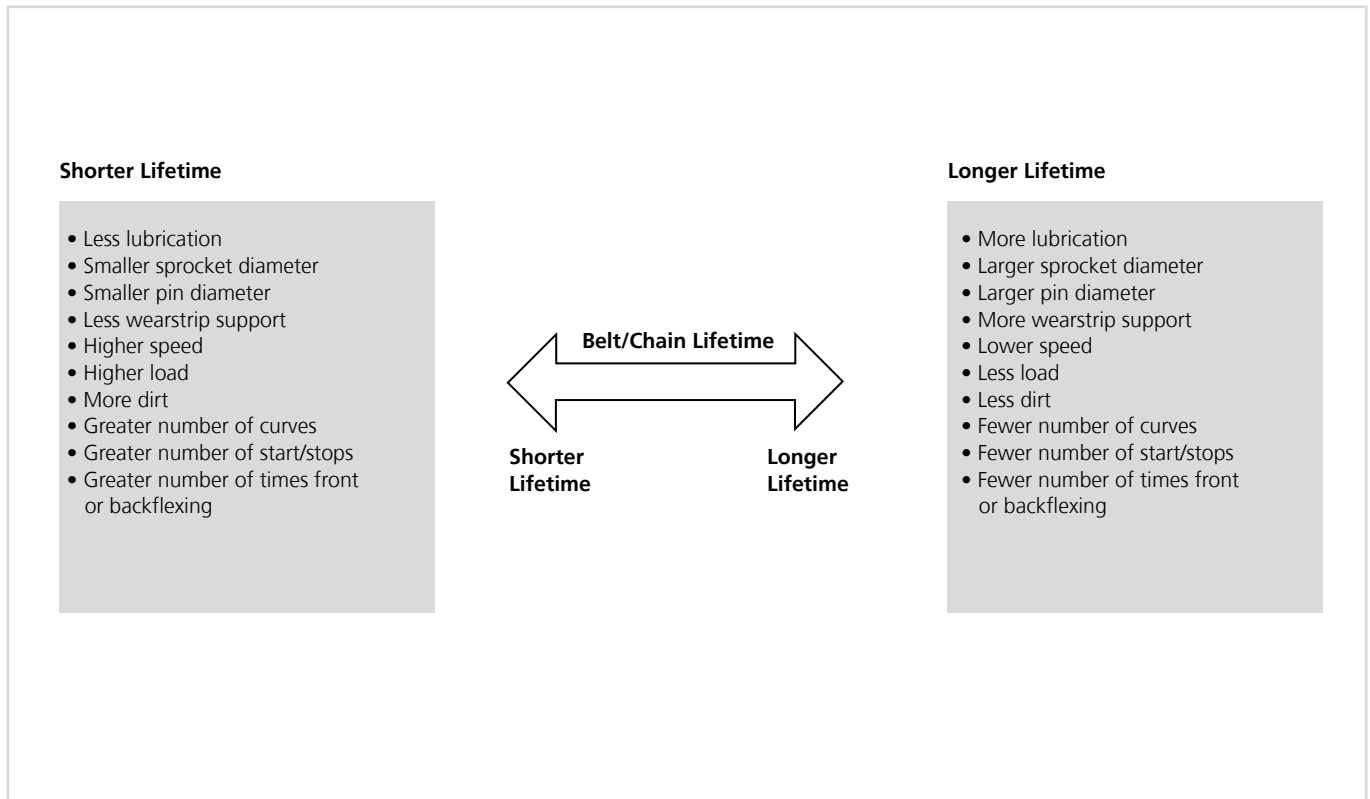

In the design stage it is helpful to consider some of the basic factors that have an effect on belt/chain lifetime and know how they can be used to increase the overall

lifetime of the belt or chain. The chart above gives a general indication of some of the more important parameters and their general effect on overall belt life.

Environmental Considerations

Successful operation of uni-chains products requires their ability to stand up to the environment that they are used in. The information below comes from previous (similar) experiences and customer input.

Specifying the right belt for the application requires a good knowledge of the environmental conditions. Below are some important environmental considerations to keep in mind when choosing a belt. Forms are available at the back of this manual that include a more complete list of most of the possible application parameters that could apply.

1. Chemical Degradation

The effect of chemicals on the performance of the supplied conveyor components must be considered at initial selection of the materials. Chemical degradation can cause premature failure of the conveyor components.

2. Radiation Degradation

Radiation from ultraviolet rays, microwaves, or any other form of radiation that can cause premature failure should be considered at the time of selection.

Ultraviolet Light

UV radiation is split into three different types: UVA, UVB and UVC. UVA and UVB are major contributors to damage caused by the sun. UVC is almost completely absorbed by the ozone layer but is found in artificial sources such as mercury arc lamps and germicidal lamps.

The Main Effects on Polymers exposed to UV

One of the main problems when considering the effect of UV rays on polymers is the intensity related to stratospheric ozone, clouds, altitude, the position of the sun height (time of day and time of year), and reflection. It is also important to remember that actual ambient temperature and humidity will accelerate any effect of the

intensity level. All types of UV can cause a photochemical effect within the polymer structure, which can be either a benefit or lead to degradation of some sort to the material.

Degradation

The main visible effects are a chalky appearance and a color shift on the surface of the material and the component surface becomes brittle. This predominantly affects the surface layer of the material and is unlikely to extend to depths above 0.5 mm into the structure. However, stress concentrations caused by the highly brittle nature of some plastics may lead to a complete failure of the component.

UV-C and uni-chains Products

UV-C will most commonly be used in the meat cutting belt applications. This is because infection through contact with surfaces is one of the most common causes of infection of foodstuffs with bacteria and mould. Generally it is conveyor belts, and in particular meat cutting belts, in the meat processing industry that are affected by this and therefore have to address the UV-C protection. This special UV-C light is usually generated from a special UV light source/radiation box. This UV-C radiation box is positioned at the meat cutting belt. Often it will be placed under the belt in the area just before the belt turns to the topside. We have divided the UV protection package into two groups:

1. UV Package (standard package)

This protection package can be used when our product is going to be used outside, where it can be exposed to UV light from the sun. In this UV package we are using our standard protection system.

2. UV-C Package

We also offer an extended UV protection where we combine our standard system with another UV absorber to get the optimal UV protection. This package comes into consideration when our product is being exposed to extreme UV light. At the moment we only provide this UV-C protection for acetal (POM) material.

3. Abrasive Requirements

Wear on chain parts highly depends on the wearstrip hardness and roughness. Generally in abrasive conditions, the harder the surface hardness and the lower the roughness of the wearstrip, the better wear resistance that combination will have. This is because the particles will embed in the softer material and wear away at the harder material.

Some examples of abrasive particles include flour, salt, sugar, sand, paper dust, glass and dirt.

4. Moisture

All plastic materials absorb water from the surroundings, but very often it is not a major factor – except when dealing with the Nylon (PA) material. Here there can be a considerable change in dimension depending on the environment where the part is placed. The absorption of water causes the polyamide part to swell and thus leads to an increase in volume. Refer to the section on Expansion due to water absorption (page 39). Tables for expansion due to water absorption can also be found in this section for coefficients so calculations can be made.

5. Temperature

Temperature relates to conveyor design and performance, within our published recommended temperature ranges, at progressive levels from 20° C (68° F) as follows: At low temperature the plastic selected will be harder, very brittle, and less resistant to impact and deflection. At high temperature plastic will be 70-85% weaker, softer with less resistance to abrasion, and greater deflection will be possible, although at lower stresses. Refer to the Calculations in Temperature Dependent Tensile Forces (page 60) or contact uni-chains engineering for assistance.

Warnings

Fire

uni-chains plastic products are, unless clearly specified, made from materials which support open flame. Products made from acetal (POM) material when so exposed, will emit toxic fumes. uni-chains plastic products should therefore not be exposed to extreme temperatures or open flame. Special care should be taken when undertaking repair work particularly when welding at a conveyor if the conveyor is fitted with plastic chains or belts.

Personal Protection

Always use safety glasses when mounting or repairing chains and belts and while securing or removing pins. Use only suitable tools in good conditions. The weight of some products calls for the use of safety shoes. When mounting/dismounting or repairing chains or belts on a conveyor, the motor must be turned off.

Design Safety Guidelines

Most plastic products will lose their mechanical properties if exposed to the sun or ultraviolet beams, which can lead to chain or belt breakage. This can also happen if the products are exposed to strong chemicals. Generally this is a problem with pH values lower than 4.5 or higher than 9.

Always make sure that there is enough space in the conveyor frame to allow chains and belts to retract or expand when exposed to temperature variations. Never exceed the maximum or minimum temperatures given for the uni-chains product range.

Care should be taken with high chain/belt speeds with

which friction can lead to heating and subsequently melting of chain/belt as well as wearstrips. Do not exceed speeds recommended for the uni-chains product range.

Use only original uni-chains sprockets with uni-chains belts and chains.

When constructing conveyors it is important always to include sufficient cover around the moving parts to prevent fingers and clothing from being caught up in the machinery. We can also supply uni-chains safety chains and sideflexing belts which leave minimal gaps when turning through curves this makes our safety chains and belts incredibly safe.

Basic Conveyor Requirements and Considerations

There are specific guidelines that go along with each conveyor that a designer should know well. Below are the basic requirements of a conveyor and an explanation of their design. Throughout this manual specific details are mentioned that expand on each of these topics. With these basic guidelines you can start to design a conveyor or retrofit an existing conveyor.

1. Clearance

The amount of clearance between the chains, belts, wear strips, channels, or any guide component must be sufficient to accommodate any temperature or fabrication variation and construction tolerance that may exist. Adequate clearance is defined as absence of binding or fit interference between moving parts and supporting surfaces (wearstrips etc.) that would cause additional resistance than what is required to support the chain/belt and load being conveyed. This condition must be held through the complete operating range of the conveyor under all conditions that it is exposed to.

2. Wearstrip Alignment

Alignment between all chain/belt and bearing surfaces must be consistent and accurate to avoid adding resistance (fit-up binding, etc.) or creating a situation where premature wear of the chain/belt or wearstrip occurs. Particular attention must be given to where the chain/belt changes direction (curves up, down or side to side). This is where the chain tension combines with the product/chain weight to increase the bearing surface requirements. At these locations we specify a minimum radius that the chain/belt will turn in either the side or backflex direction (see product catalog data).

3. Speed

For speeds over 30 m/min. (100 ft/min.) the use of a soft

start motor control is recommended. High speed conveyors must also be designed with wear strips that will not melt when the speed is combined with the load at the bearing surfaces. Lubrication of the chain/belts can also be very beneficial in high speed conveyors. Speed is a very complicated issue, and it is difficult to come up with guaranteed figures. This is mainly because of the many variables from one conveyor to another.

These variables could include:

- Surface roughness of the wearstrips
- Actual speed vs. designed speed
- Load
- Cooling/lubrication
- Surrounding temperature
- Actual friction
- Possibility to conduct the heat away

Sideflexing belts must be treated as a special situation and there are charts available for speed/load determination on these. uni-chains' engineering can recommend wear strip materials that will stand up (to most conditions).

4. Conveyor Length

The maximum length of a conveyor can be limited by the effects of elastic surging even if the belt is below the tension limit. Surging/pulsation occurs when the chain/belt stretches and the spring force stored becomes strong enough to accelerate a portion of the belt and product. This portion of the belt is accelerated at a rate that is equivalent to the force stored in the chain/belt. It is independent of belt width and is very dependent on belt resistance and the spring force constant of the chain/belt type and material. Surging can be a problem in some cases where product stability is a factor or where fatigue

loading is a problem. It is dependent on conveyor configuration, length, product weight and speed, among other factors. As a general rule surging can be an issue for straight running conveyors 20 m (65 ft) center distance or greater and for sideflexing conveyors 12 m (39.4 ft), surging is more of an issue at slower speeds than at high speeds.

5. Sprockets

Sprockets should be located in a position relative to the chain/belt such that they engage so that the sprocket pitch diameter intersects the pin center line. Chains

typically use one sprocket per shaft. For belts the rule of thumb for the minimum number of sprockets is the width of the belt (in inches) divided by six (rounded up) and plus one per shaft. If this result is an even number it is common practice to add another sprocket to make an odd number and have a true center sprocket. More sprockets will be required based on belt tension and temperature. Some belts have sprocket paths that must be followed when locating the sprockets on the shaft. The center sprocket on both shafts is generally fixed and the others are allowed to move laterally with the expansion and contraction of the belt as it changes with temperature.

Dimension Definitions

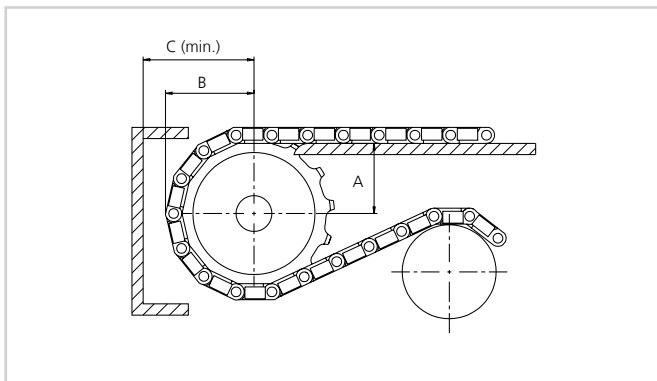

Figure 3-1

A – The vertical distance from the centerline of the shaft and sprocket to the top of the wear strip. This distance will remain the same until the chain/belt engages with the sprocket. After engagement this distance will vary as the pins will raise and lower and this effect is called Chordal Action. Refer to section on Chordal Action (page 39). See figure 3-1.

$$A = p_d \times 0.5 \times \cos(180/z) - l$$

B ± (3.0 mm) 0.13 in. – The horizontal distance from the centerline of the shaft to the top surface of the belt. See figure 3-1.

$$B = p_d \times 0.5 + (t-l)$$

C – The minimum distance between the center of the shaft and any framework. This is determined by sprocket diameter. Care should be taken that there is adequate clearance between the frame and product supports, side guards or other accessories on the belt or chain. See figure 3-1.

$$C_{min} = b + 6$$

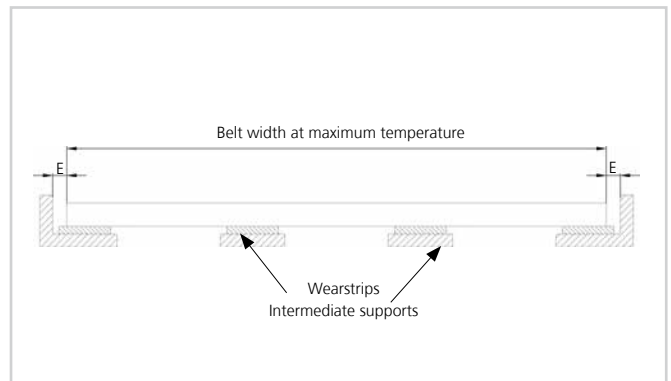

Figure 3-2

E – The clearance between the side of the frame and the edges of the chain/belt. The minimum of 3 mm (0.12 in.) should always be measured when the belt is at maximum operating temperature. This will ensure that the belt is at its maximum width and enough clearance will always exist. See figure 3-2.

Note: This recommended clearance is for straight running belts only. Guide clearance for sideflexing belts should be calculated on an individual basis. See figure 3-2.

See the calculations section (pages 63-79) in the back of the manual to determine how much expansion your belt/chain will undergo.

- p_d = Pitch diameter of drive/Idler sprocket, mm (in.)
- z = Number of teeth drive/Idler sprocket
- t = thickness of the belt including possible attachment, mm (in.)
- l = Distance from the bottom of the belt to center of the pin, mm (in.)

Drive Concept

Shaft Selection

Conveyors can use either round or square shafts. Square shafts have a few advantages over round shafts. To drive the sprockets round shafts use keyways where square shafts drive the sprockets with a square bore on their own. Square shafts can transmit higher loads and have less deflection than round shafts with keyways. Sprockets with square bores will slide more easily on square shafts than round bored sprockets do on keyways and square bored sprockets are easier to align. Square shafts are recommended over round shafts when feasible.

Square shafts are recommended on long and big shafts (sq 60 x 60 mm) (sq 2.5 x 2.5 in.) or bigger. Choosing the correct shaft size is crucial for chain/belt life. Torsion or bending in the shaft will misalign the sprockets so they do not engage the chain/belt properly and cause greater wear. This can also cause uneven forces in the belt that can lead to breakage or pin migration. Calculations for proper shaft size can be found in Dimensioning of Shaft in Calculations (page 73).

Torsion Loading

Since the drive shaft is only attached to the motor on one end and the other end is resting in a bearing, torsion occurs in the shaft. As the motor engages the end of the shaft that it is rigidly attached to, the shaft twists under the load of the chain/belt and the product. The larger the sprockets, the greater the torsion load on the shaft. If a particular size shaft is desired and the torque to be ab-

sorbed is greater than the maximum torque on shaft, use smaller sprockets and recalculate the torque on the shaft. Since the sprocket diameter has been decreased, the motor's RPMs must be increased to maintain the same speed. Other methods to address torsion include placing a motor on both ends of the shaft or placing the motor in the center of the shaft.

Aligning the Shafts

To ensure smooth operation without problems the conveyor must be absolutely level and the shafts must have the correct placement with respect to each other. For straight running conveyors the drive and idle shaft must be parallel to each other. For sideflexing belts the drive shaft must be perpendicular to the straight section after the final curve and the idle shaft must be perpendicular to the straight section before the first curve. Shaft alignment can be checked using the methods shown below.

In the method figure 3-4 on the left, the distance "l" must be the same at both sides and the length of the two diagonals "d" must be the same.

The method figure 3-5 to the right can be useful for long conveyors. You can choose the measure of "a" and "b" as you wish. The point is that the two "c" values have to be identical.

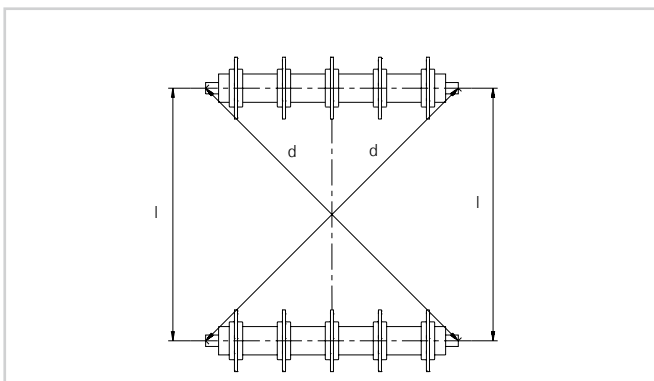

Figure 3-4

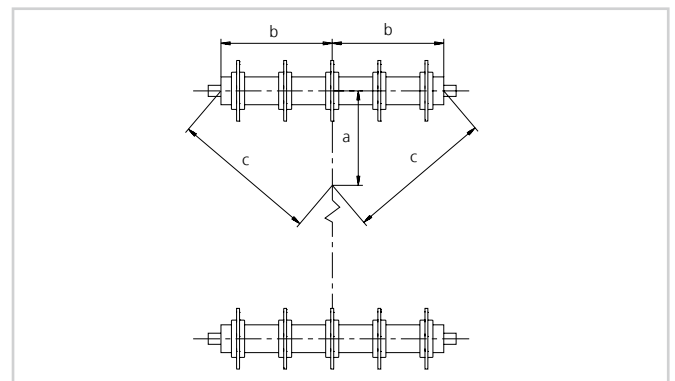

Figure 3-5

Note: The center line must be very accurate. The alignment of the sprockets must be performed in both the drive and idler ends.

Drive Concept

Retaining Sprockets

The center sprocket on both the drive shaft and idle shaft should be laterally retained to ensure proper belt alignment throughout operation. The other sprockets should be left to move freely along the shaft. This allows the sprockets to move with belt expansion and contraction from changes in operating temperature.

The uni-chains product range offers retainer rings for both round and square shafts. Refer to our belt catalog for more information.

Intermediate Bearings

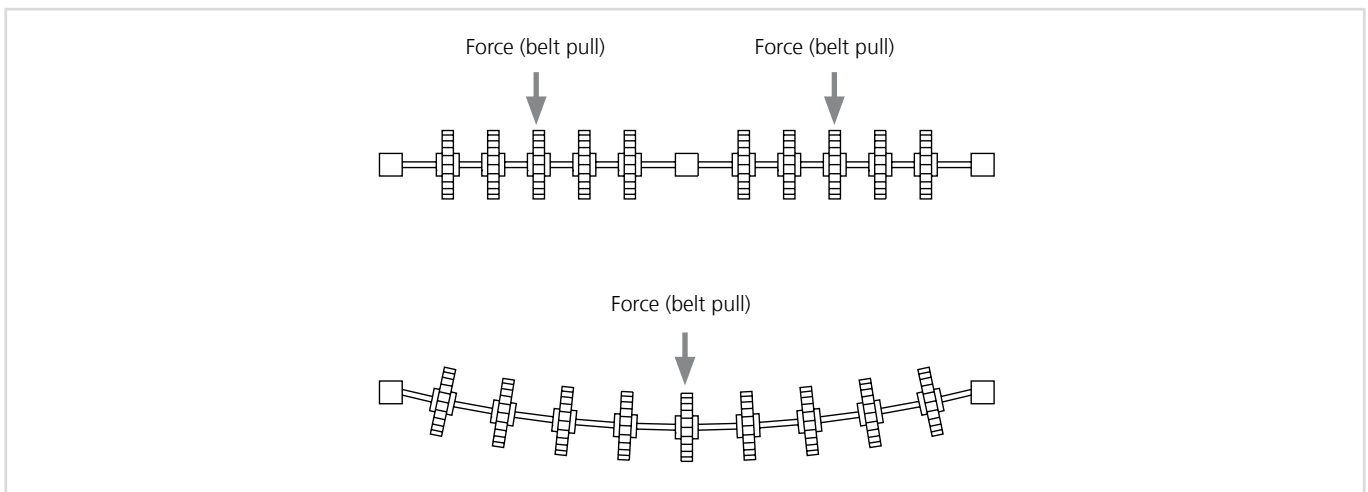

Figure 3-6

An intermediate bearing is placed in the center of the shaft to reduce shaft deflection. Excessive shaft deflection

as seen on figure 3-6 can cause disengagement between belt and sprocket as well as shaft breakage.

Note: Drawing has been exaggerated for understanding purposes.

When working with a wide conveyor or a conveyor with a high tensile load the shaft must be large enough to handle the load without deflection, or intermediate bearings should be considered. In cases where a sufficiently large diameter shaft is not an option, intermediate bearings are a must. An intermediate bearing is placed at the center of the drive shaft and its purpose is to reduce shaft deflection. Minimal shaft deflection will ensure sprocket and chain engagement.

Mounting of intermediate bearings should be noted since intermediate bearings are usually split journal bearings. The bearings should be aligned so that the split is perpen-

dicular to the carryway. If they are not mounted in this alignment, the reinforcement strength of the bearings is reduced significantly. Intermediate bearings also require significant space to install, so increasing the sprocket diameter may be necessary. When increasing the sprocket size, keep in mind if there is a transfer at this point. Refer to Shaft Calculation Section (page 78).

Drive Concept

Rollers as Idle Shafts and Sprocket Replacements

In some cases it is more advantageous to use rollers instead of an idler shaft with sprockets. One case where this should be used is, for example, where the designer wants to avoid using intermediate bearings. With wide

conveyors with higher loads, a roller can withstand more load and can reduce the need for intermediate bearing(s).

Note: If a roller is used on the idle shaft it does not provide the benefit of the horizontal tracking of the sprockets. Measures can be taken to guide the belt such as edge guide wearstrips on the side frame or a flange on the sides of the roller to track the belt.

Drive Types

In practice three types of drive units are commonly used for conveyors. The most widely used is the gear motor. In industries where the demands for hygiene are very strict (e.g. the food industry) drum motors are sometimes used. As a specialty hydraulic motors are often used for packing lines on industrial trawlers. Also used are soft starting motors and fluid couplings for high speed conveyors.

Soft starting Motors and Fluid Couplings

Starting a high speed conveyor without proper acceleration can wear out the belt/chain at an accelerated rate. Soft starting motors and fluid couplings help to gradually accelerate the conveyor to its operational speed. This reduces initial belt tension and the stress between the links and pins.

Geared Motors

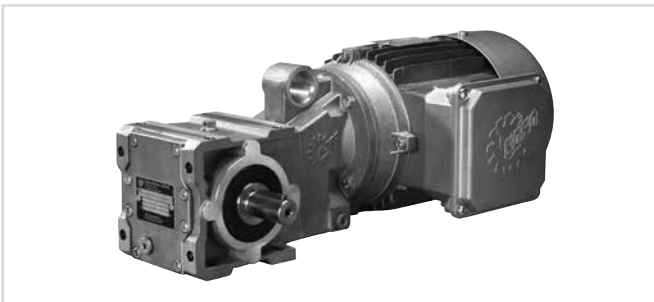

Figure 3-8

The main advantage of the geared motor is the wide variety of sizes and designs available at a reasonable price. Be aware that the efficiency of certain types of worm gears can be very low.

Advantages

- Low price
- Wide variety
- Large moments transfer

Disadvantages

- Bulky (at the side or under the conveyor)

Drum Motors

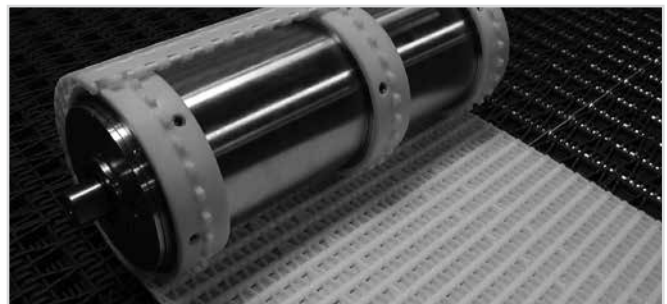

Figure 3-7

Advantages

- No protruding ends
- Easy to clean
- Cost effective
- High efficiency
- No maintenance

Disadvantages

- Need for keeping a spare on hand
- Secure heat generation
- No usage for high loads

Hydraulic Motors



Figure 3-9

Advantages

- Large load capacity compared to the dimensions

Disadvantages

- Noisy
- Requires a hydraulic supply station

Straight running Conveyors

The simplest design of a conveyor is a straight running conveyor with a single drive unit. In certain applications, multiple drive units are required, such as a combiner or decombiner.

Elevating Conveyors

The principles in the next section apply for both belts and chains.

Incline Conveyor

The typical inclining conveyor is characterized by the products being elevated from one level to another. The possible inclination angle is determined by the friction coefficient between the product and the chain or belt. Depending on the product type (friction against chain/belt) products can be elevated at an angle of 3-4° without sliding back. If the angle exceeds 3-4° it is usually necessary to use rubber inserts, product supports or AmFlights to prevent the products from sliding down. Depending on the characteristics of the products rubber inserts can overcome angles of 20-40°. Figure 3-10. Testing is always recommended to determine the possible incline angle for a particular product/application.

For a typical incline conveyor the drive shaft is located at the top. A take-up device is often used on the idle shaft to help maintain adequate tension on the return side. In some cases it is beneficial to use a flanged roller on the idle shaft rather than sprockets so that excess belt from the return does not bind up at the sprockets. Figure 3-11. The return can be supported with wearstrips, rollers or return shoes.

In general the drive is located at the top and either a take-up system or a catenary sag can be implemented at the bottom.

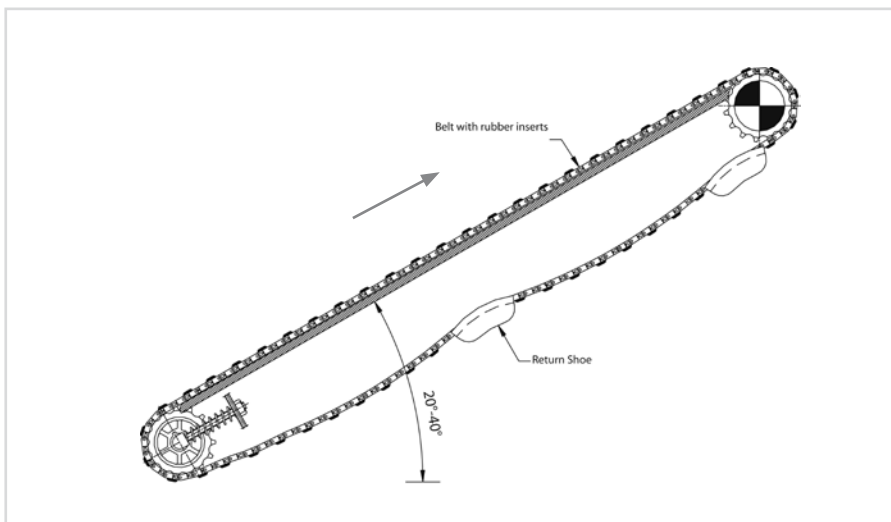

Figure 3-10

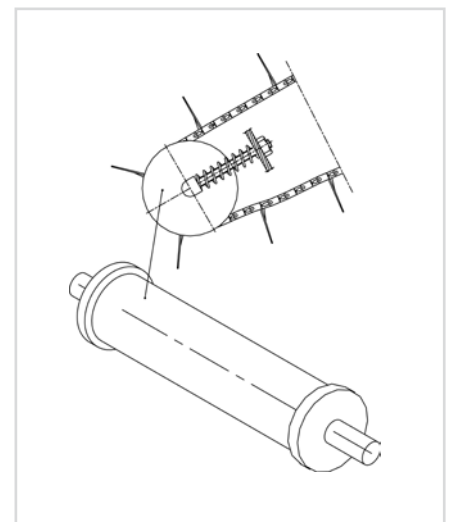

Figure 3-11

Elevating Conveyors

Often incline and decline belts have product supports. Special care must be taken on the return side when product supports are used. See figure 3-12. The most common method is to indent the product supports and support the belt from the edges. For wide belts it is sometimes necessary to support the belt at locations across the width as well as the edges. In that case a gap

or gaps across the width can be used. As an alternative it is possible to slide the product supports directly on the return wearstrips, but this causes wear points on the top of the product supports. Also, some chains and belts have bottom tabs which can be used to let the chain or belt hang free from them on the return.

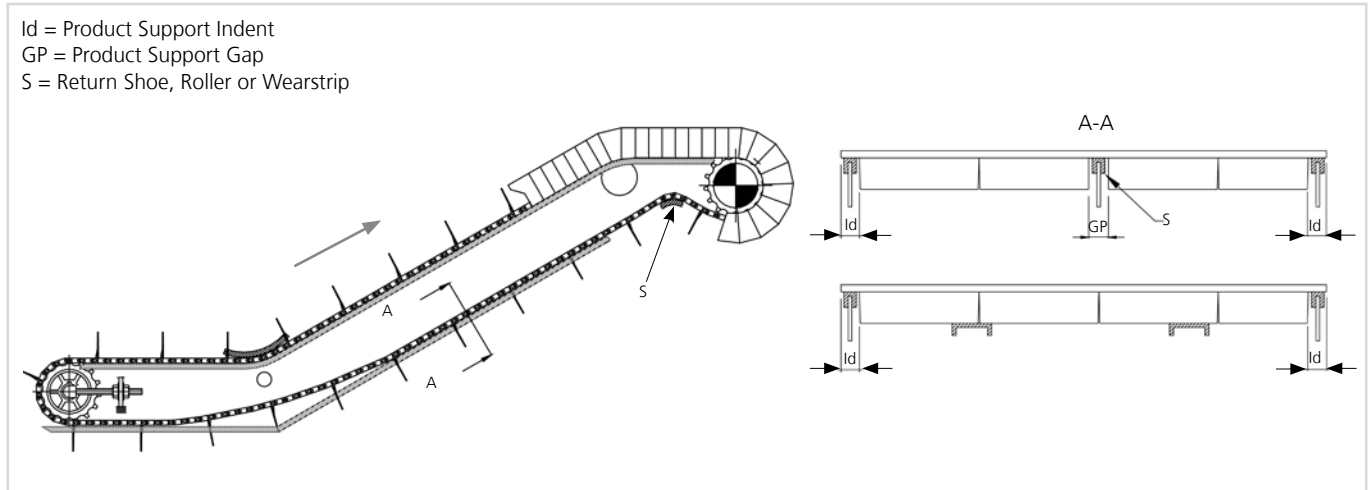

Figure 3-12

With straight product supports, inclines of up to 60° are usually possible. Inclines of 90° or more can often be accomplished in a closed system. Between 60° and 90° it is necessary to use bent product supports in open systems. With bent or cupped product supports (uni MPB) even inclines of 120° are possible.

An incline or decline conveyor may include one or more horizontal sections. Typically there is a horizontal inlet at the lower end where the products are loaded and a horizontal section at the top where the products leave the conveyor. In the areas where the belt transitions from horizontal to incline it is necessary to hold the belt down. This can be done with a roller, wearstrip or hold down shoe. If product supports are used they can be indented or manufactured with gaps as shown in figure 3-13. If possible a roller hold down is preferred to reduce wear on the support points.

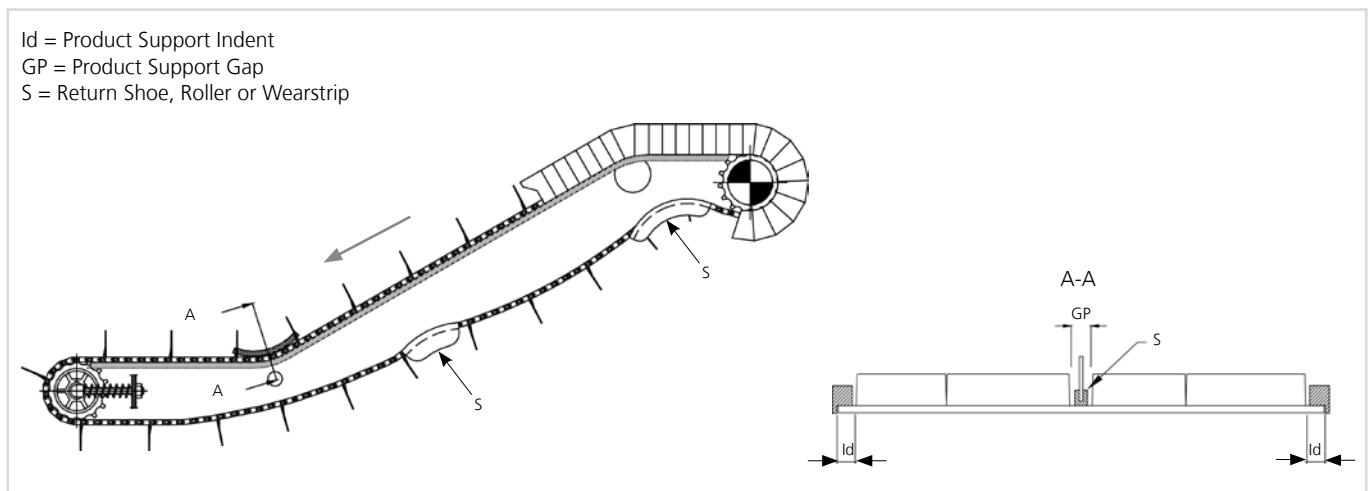

Figure 3-13

Elevating Conveyors

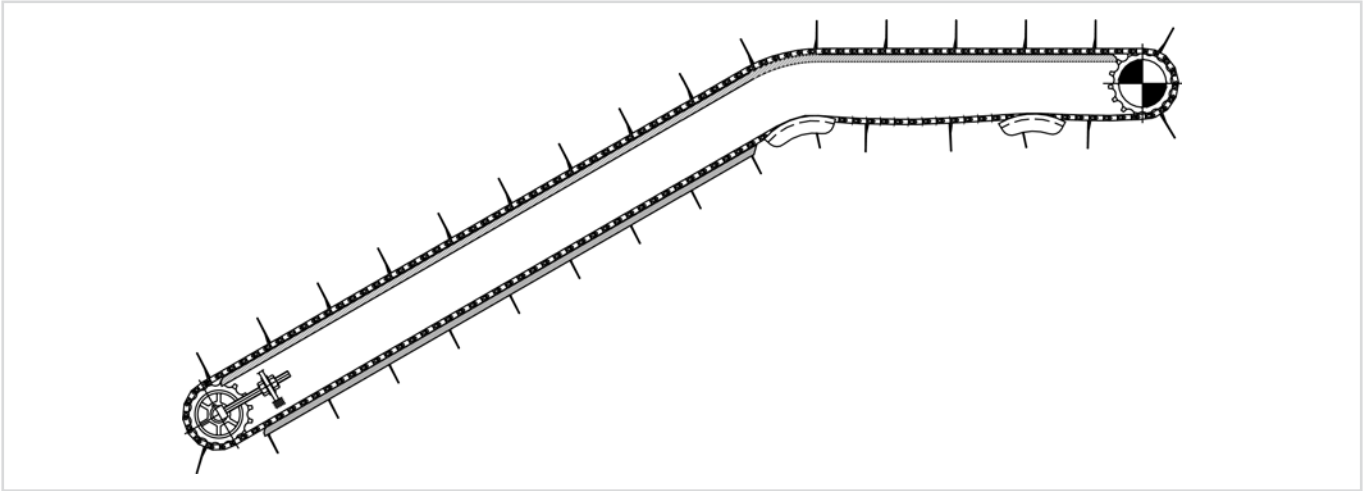

Figure 3-14

Sideflexing Conveyors

Straight running conveyors are still the most common type of conveyors. The optimization of the production layout and the reduction of manual processes, however, require conveyors that can transport products in more than one direction. Sideflexing conveyors can be made with both chain and belt in the different ways shown in figure 3-15, figure 3-16, figure 3-17 and figure 3-18.

Sideflexing Chains

Sideflexing Chains, single Track

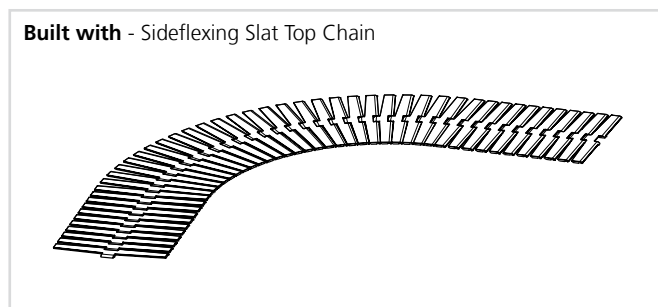

Figure 3-15

| | |
|---|--|
| <p>Advantages</p> <ul style="list-style-type: none"> - Simple design - Small footprint - Strength | <p>Disadvantages</p> <ul style="list-style-type: none"> - Limitations in the widths - Limited product support (the large openings in the outer radius limit the size of the products to be transported) - Safety |
|---|--|

Sideflexing Chains, multiple Tracks

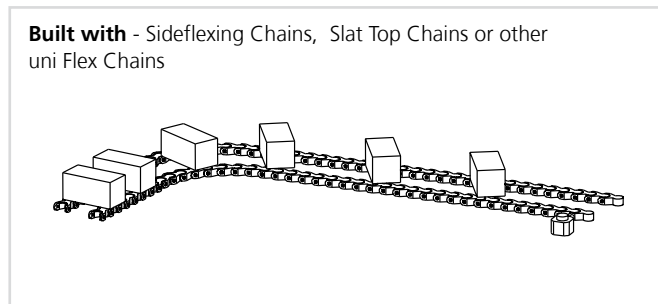

Figure 3-16

| | |
|--|--|
| <p>Advantages</p> <ul style="list-style-type: none"> - Small footprint - Strength | <p>Disadvantages</p> <ul style="list-style-type: none"> - Limited product support - The product orientation changes because of different speeds of the individual chains in the curve |
|--|--|

Sideflexing Conveyors

Sideflexing Modular Belts

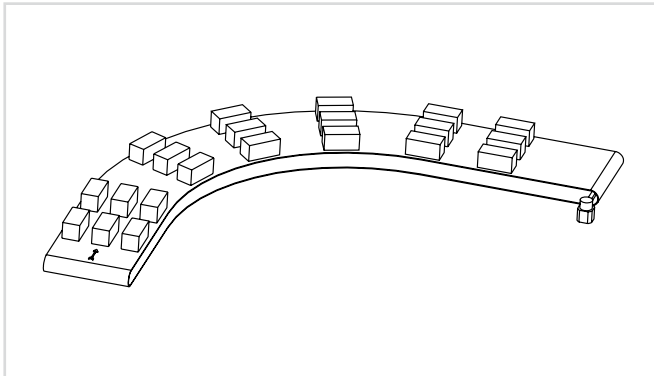

Figure 3-17

Advantages

- Only one drive station required
- No intermediate dead plates
- Product orientation is not affected
- Stable product support also of small products
- Safety (When the belt turns in the curve there will be no large openings in the belt surface)
- It is possible to build wide sideflexing conveyors
- Safe belt control. Wearstrips and sprockets secure positive belt control

Disadvantages

- Straight sections required before and after curves
- Lower strength than chains

Basic L-Shape

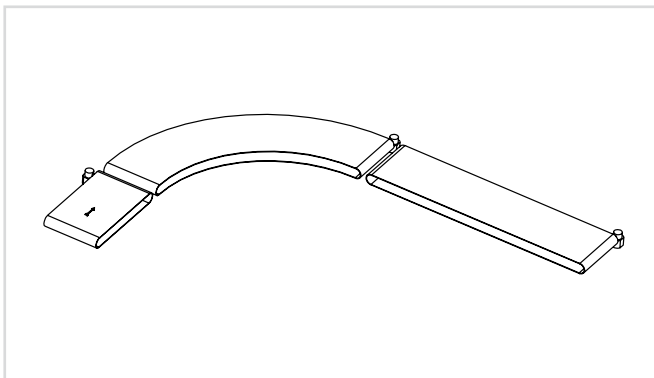

Figure 3-18

How does a sideflexing Belt Work

A simple example of a sideflexing conveyor is the L-shape: Straight section, curve, straight section. The belt runs as a straight running belt in the straight sections. In the curve, the belt pitch compresses at the inner radius to compensate for the difference of the arc length. After the curve, the belt is stretched and runs again as a straight running belt. In the curve section only the outer edge remains at true pitch. This outer section transfers all the tensile forces.

Figure 3-18 shows an L-shape conveyor three sections. With sideflexing modular belts this layout is possible with a single drive.

Sideflexing Conveyors

True Pitch in outside Radius

When the belt travels straight, the pitch is the same over the entire width. The belt is able to distribute the tensile forces across the full width of straight running sections.

When the belt travels in the curve, the pitch will vary over the belt width. Only the outer radius will maintain the original pitch and, therefore only the outer edge is able to transfer tensile forces. See figure 3-19.

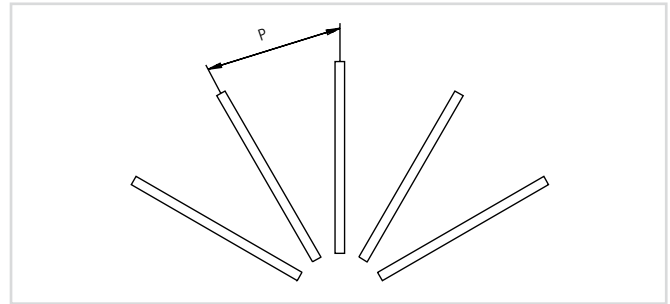

Figure 3-19

Note: When calculating the belt length it is important to use the outer arc length.

Load Line

To understand the function of a sideflexing belt it is important to understand the distribution of the forces in the belt. In a straight running belt the load lines are distributed evenly over the belt width.

In a sideflexing belt the links are compressed in the inside radius and thus cannot absorb any tensile forces. Hence, the entire tensile force must be transferred on the outer radius where the pitch is normal. The illustration figure 3-20 shows the distribution of the tensile forces "**load lines**" in a sideflexing belt.

In the curve the tensile force will concentrate in the outside radius. After the curve, the tensile force will begin to spread over the entire belt width again in the form of a fan and after a certain length, the forces will again be distributed evenly like in a straight running belt.

In straight running belts, where the tensile force is distributed evenly, the tensile capacity will increase in relation to the belt width.

In a typical sideflexing belt only the outer hinges of the belt can transfer the entire tensile force in curves. Therefore a larger width sideflexing belt will not necessarily have increased tensile capacity in the curve. Some uni-chains sideflexing belts do have the ability to distribute the curve load over some of the outer hinges and, therefore, have different load ratings for different widths. See uni-chains' belt catalog for specific belt values.

Layout following the Load Lines

It is important to observe these load lines when designing the conveyor.

- To ensure correct engagement and optimum drive, the sprockets must be placed where the belt is running

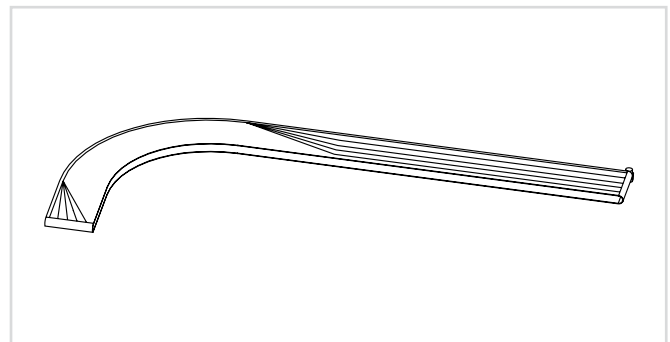

Figure 3-20

straight and the forces are evenly distributed. uni-chains provides recommendations for placing the drive station at a minimum distance from the curve.

This required distance varies by belt type and can be found in the belt catalog or in the design guidelines for the specific belt if available.

- At the idler end it must be ensured that the belt is stretched, so that the pins in the belt are parallel with the idler shaft when they rotate around it. A minimum straight section is recommended before the curve to ensure correct rotation around the idler shaft. This dimension varies by belt type and can be found in the belt catalog or in the design guidelines for the specific belt if available.

- In an S-shaped conveyor it is important that the tensile force is distributed evenly across the belt width between the two curves before it is compressed on the opposite side of the belt. A minimum straight section between two opposite running curves is recommended to ensure a good distribution of the tensile force. This dimension varies by belt type and can be found in the uni-chains belt catalog or in the design guidelines for the specific belt if available.

Sideflexing Conveyors

Reducing overall Dimensions for Sideflexing Belt Conveyors

Reducing Sideflexing Belt Width ratio

Some belts have a smaller belt width turn ratio than others. By selecting a tight radius belt the dimensions of the curved sections are reduced because the outer turning radius is smaller than the standard radius belt.

Reducing Belt Width

All dimensional requirements for a sideflexing belt layout are related to the belt width. If the belt width is reduced the overall dimensions will be reduced as well. There are several ways to do this. For example, using a belt with side tabs or bottom tabs can allow the belt to be narrower than the products conveyed because the product can overhang the edges. Using this narrower belt will make the overall conveyor dimensions smaller.

Split wide Conveyors in two Belts

Another method of reducing the belt width is by splitting a conveyor into two parallel belt lanes. For example two 229 mm (9 in.) wide belts can thus replace a 457 mm (18 in.) wide belt and reduce the space required by 66%. If this option is chosen, attention must be paid to the different speeds of the two belts in the curves and the fact that there is a distance between the two belts.

Placing the Drive

Where to split long Conveyor Layouts

The drive unit must be placed so that the chain/belt is pulled. As a consequence pushing the belt is not recommended.

Belt tension increases as you move from the idler shaft to the drive shaft. On straight sections the tension will double if the belt length is doubled.

In curves, the friction will exponentially increase against

the inner radius of the guide rail. It takes more power to pull the belt through a curve. The higher the load on the belt before the curve, the larger the increase in the tension.

When placing the drive it is important to minimize the sections before the curve and maximize the sections after the curve. It is also possible to implement a center drive located close to the curve as a way to reduce tension. See figure 3-21 and figure 3-22.

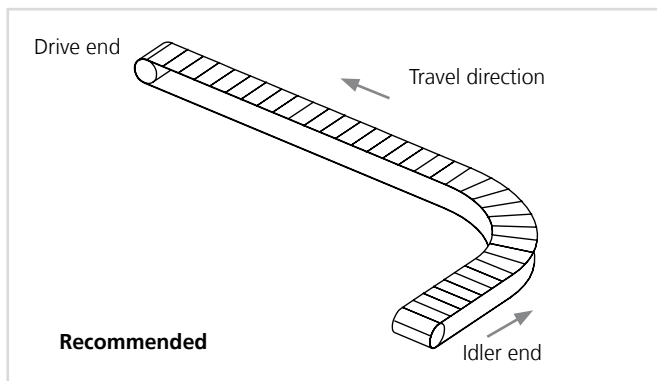

Figure 3-21

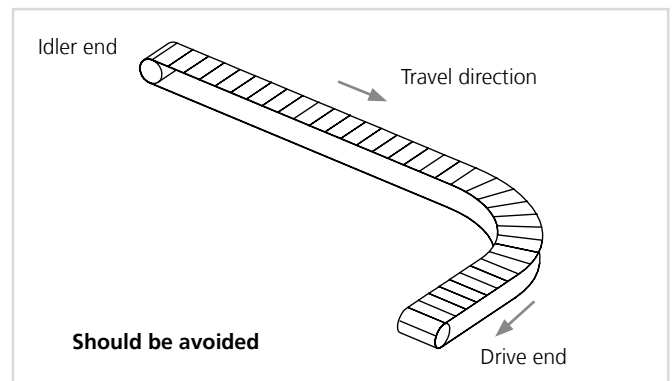

Figure 3-22

Sideflexing Conveyors

Load & Speed Properties

The permissible tensile force of a sideflexing belt depends on the ability of the outer hinges to bear the load or distribute the load. In sideflexing belts, however, the speed is also an essential parameter. Therefore attention should be paid to the maximum permissible tensile forces stated in the catalog as these will decrease as speed increases.

In sideflexing belts there is a great inward radial load in the curve. At the point of contact between belt and wearstrip, heat will occur due to friction. The temperature influences the friction properties of the materials. The friction coefficient will increase as the temperature increases and a higher friction coefficient will result in more heat being generated. It is important to avoid this as it could result in either the belt/chain or the wearstrip melting.

On the basis of numerous tests and data collected from existing applications, uni-chains has established some load/speed relations between our belt types and materials against various wearstrip materials. These are sometimes called Pressure-Velocity (PV) Limits. These load-speed relations can be found in the appendix of this manual. See appendix pages 96 to 98.

Precautions with Catenary Sags for sideflexing Belts

Over time sideflexing belts can elongate more in the loaded side of the belt than the other. Catenary sags and tension rollers must be able to absorb this uneven elongation and care must be taken that the return section can accommodate this.

Sideflexing Conveyors

Mounting of Sprockets

Drive

As mentioned earlier in the majority of sideflexing belts most of the tension will be on the outer radius in the curves and therefore the highest load will also be on the outermost

sprockets. The distance between the sprockets on the driving shaft should therefore be smaller for the sprockets placed closest to the outer radius. See figure 3-23.

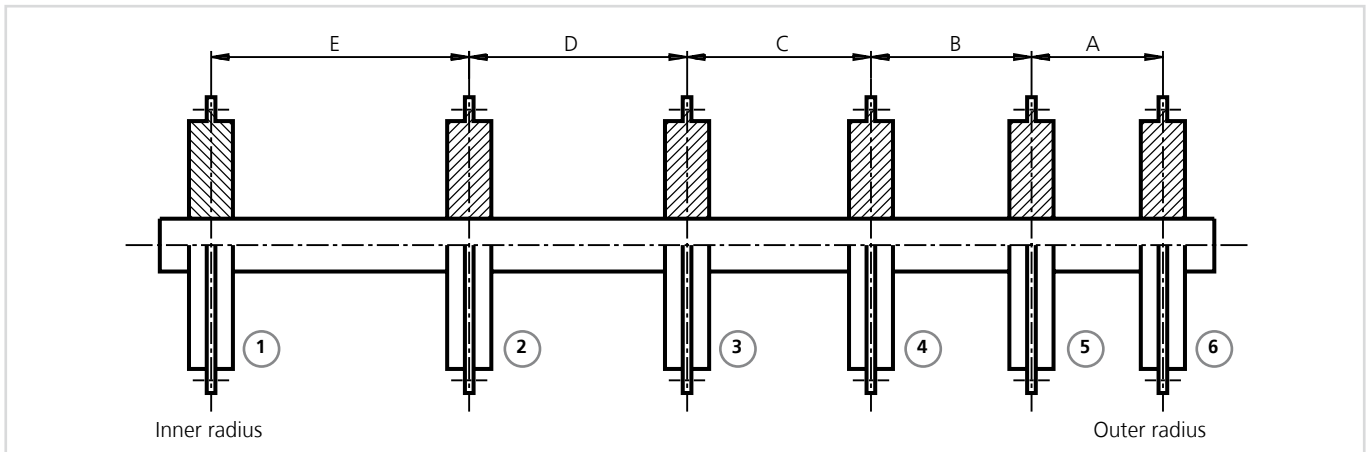

Figure 3-23

Distance between Sprockets

$A < B < C < D < E$

Sprocket #3

Fixed to the shaft

Sprockets 1, 2, 4, 5, 6

Moving freely axially

Idler End

The idler shaft can be constructed in several different ways. If guidelines are followed for minimum straight sections, sprockets can be used in the same configuration as on the drive shaft. If low noise or tight transfer is required uni-chains recommends that sprockets without teeth are used, i.e. either a disc or a shaft without teeth if support over the entire width is required.

Note: The uni Flex ONE belt is an exception to the above recommendations. Because of the way the load is distributed through this belt the sprockets are always evenly spaced on the belt. Refer to the uni-chains belt catalog for specific sprocket placement instructions.

Spiral Conveyors

Basic Concept

Spirals are often used for continuous processes such as proofing, cooling or freezing. In its simplest form a Low Tension spiral consists of an upright motor driven drum, or cage, around which a sideflexing conveyor belt is wrapped. The conveyor belt moves either up or down in a helical path and is supported by continuous belt support rails fixed to the other frame of the conveyor in a helical path.

The belt is primarily driven by the frictional force between the rotating cage and the inner edge of the belt, and by a secondary drive force, the take up motor that positively drives the belt with sprockets. See figure 3-24.

The secondary drive force applies sufficient pulling force to the conveyor belt to ensure that it wraps around the cage, so that there will be contact between the cage and the inner edge of the belt, and therefore a frictional driving force between the belt and cage.

Basic Principles of Operation

To understand how a Low Tension spiral works, it can be compared to a simple rope and capstan used to move a ship into a docking area. The capstan turns when the drive motor is turned on. The rope attached to the ship is wrapped several times around the capstan. Nothing will happen until someone pulls the loose end of the rope. When the rope tightens around the capstan, the frictional force of the capstan against the wraps of rope, plus the drive force of the motor driving the capstan will be able to pull the boat into dock. This will continue as long as someone keeps pulling on the rope. See figure 3-25 and figure 3-26. The Low Tension spiral works in a similar manner. One big difference is that the belt (rope) is endless. So we have to have a place for the belt to accumulate, as it gets longer from wear, higher belt tension or temperature changes. We let the belt accumulate right after the second drive, in what we call the belt take up loop. Another difference is that instead of a big load at the end of the rope, we have the load spread all over the belt. The belt has to remain level to carry the product, so we have continuous belt support rails under the belt. Low tension spirals are a big friction machine. They use the friction between the moving cage and the inside edge of the taut belt to provide the drive means. The main drive has to overcome the friction force between the loaded belt and the support rails. How well this all works is a function of the coefficient of friction between belt edge and cage and belt underside and support rails.

General System Design Requirements

For details on basic general system requirements for Low Pull spiral systems using modular belts, please contact uni-chains engineering.

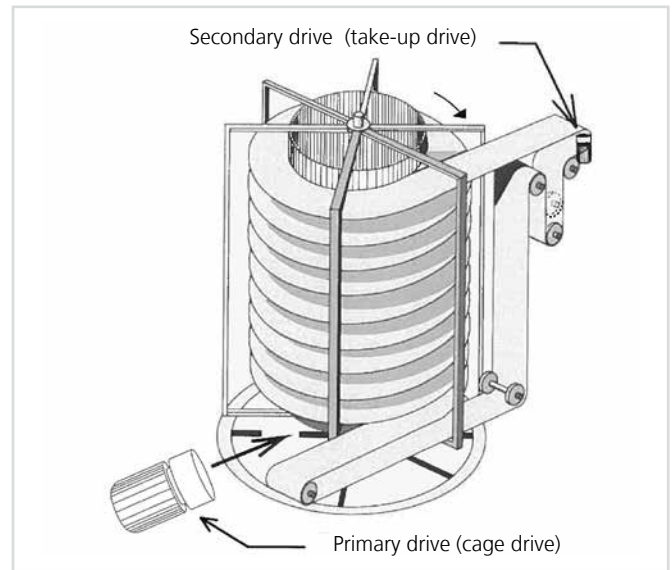

Figure 3-24

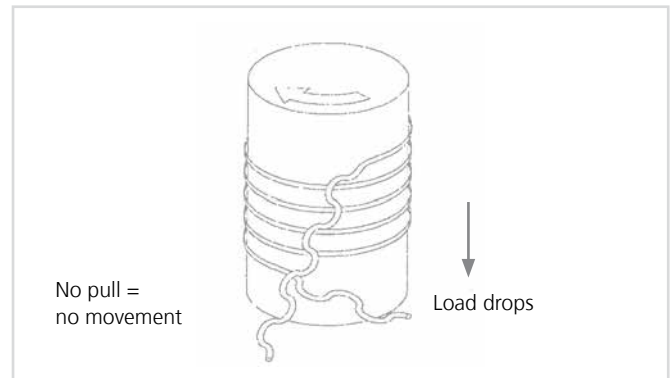

Figure 3-25

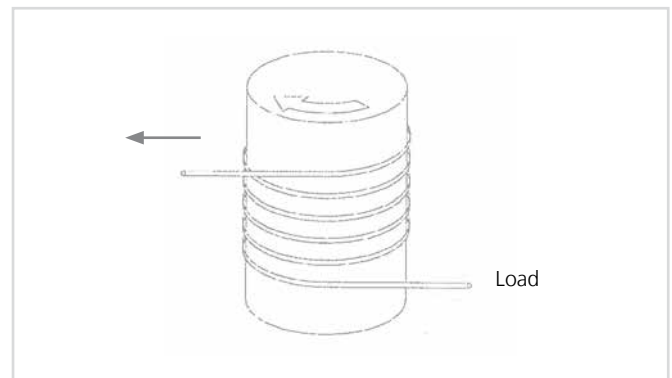

Figure 3-26

Transfer Guidelines

It is not practical to make a conveyor if you cannot place the products on the conveyor or transfer them at the end of the transport. In practice it is also impossible to build

sufficiently long conveyors. So there is usually a need to transfer products from one conveyor to another. Following are different methods to do this.

Side Transfer

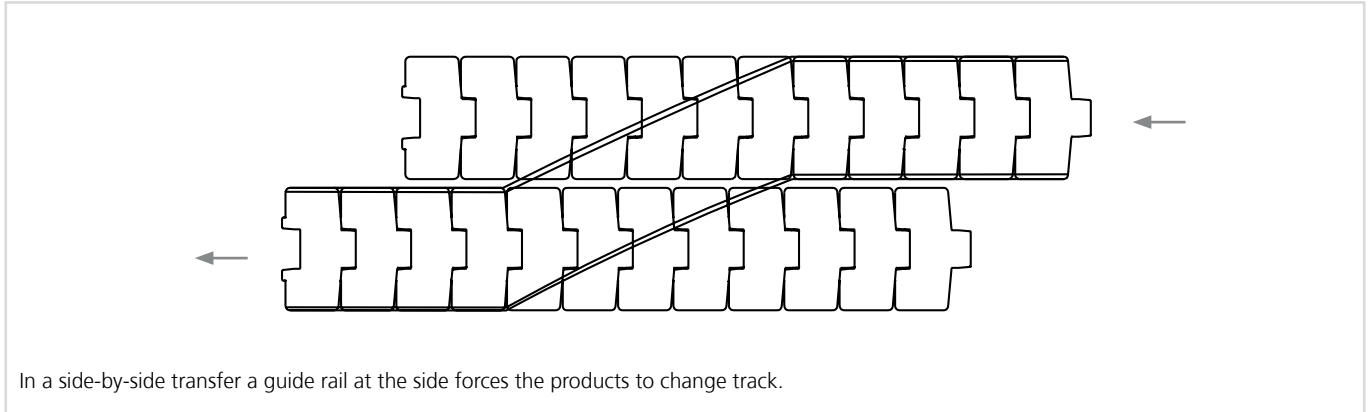

Figure 3-27

Inline Transfer

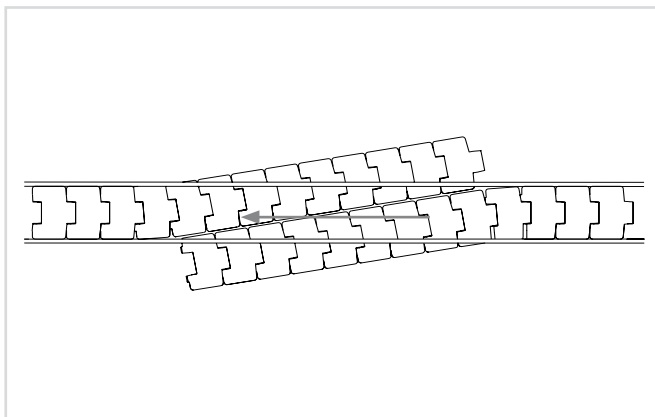

Figure 3-28

Inline transfers are like side transfers but the guide rail is not bent and the product is not moved laterally. This is much less common than a side to side transfer seen above where the conveyors are parallel and the guide rail is bent. See figure 3-28.

90 degree Transfer

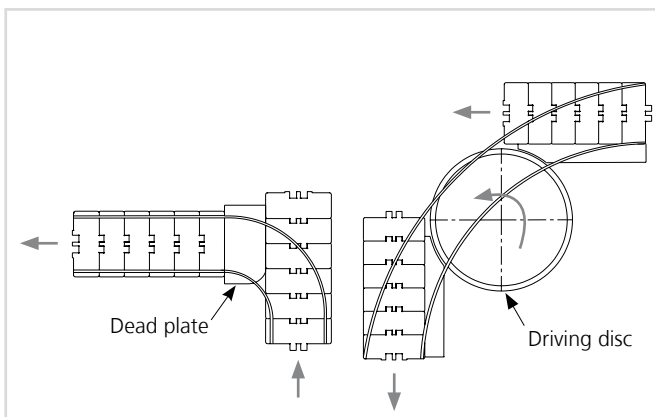

Figure 3-29

A 90° transfer can be made with guide rails and a dead plate or turn discs. Rollers can be substituted for a dead plate depending on the designers needs. See figure 3-29.

Transfer Guidelines

End off/End on

With a nosebar the front flex radius can be reduced as a function of the belt pitch. As a rule of thumb uni-chains recommends using a minimum nosebar diameter of 2 x belt pitch unless specific nosebar dimensions are stated in the uni-chains catalog. uni-chains 0.5 in. pitch belts have been specifically designed for use with nosebars and have a profile on the bottom of the modules so that they contour to the nosebar better. Refer to the uni-chains belt catalog for specific minimum nosebar diameters for these belts. It is possible to do this type of end to end transfer with chains as well, however the transfer point will be much larger because of the greater pitch.

If possible it is always recommended to use a nosebar that can rotate freely (such as a roller) to reduce the friction, noise and wear caused at this point. Due to the usually small diameter and sometimes large belt widths, the deflection can sometimes limit

the ability to use a roller. However using a nosebar with small rollers embedded in it or using a roller with support bearings underneath can be a solution to this. See figure 3-30.

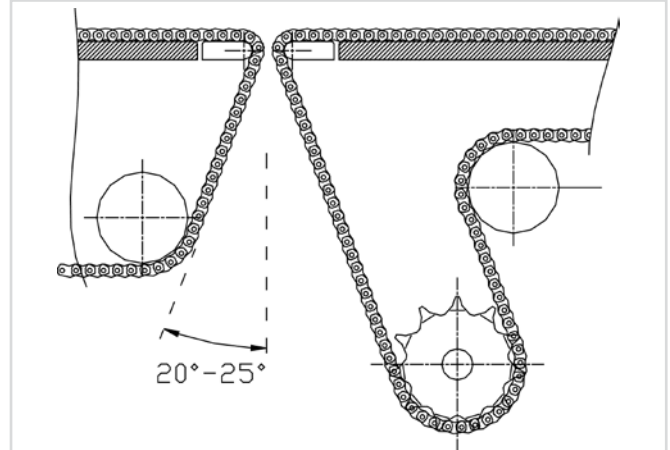

Figure 3-30

Dead Plates

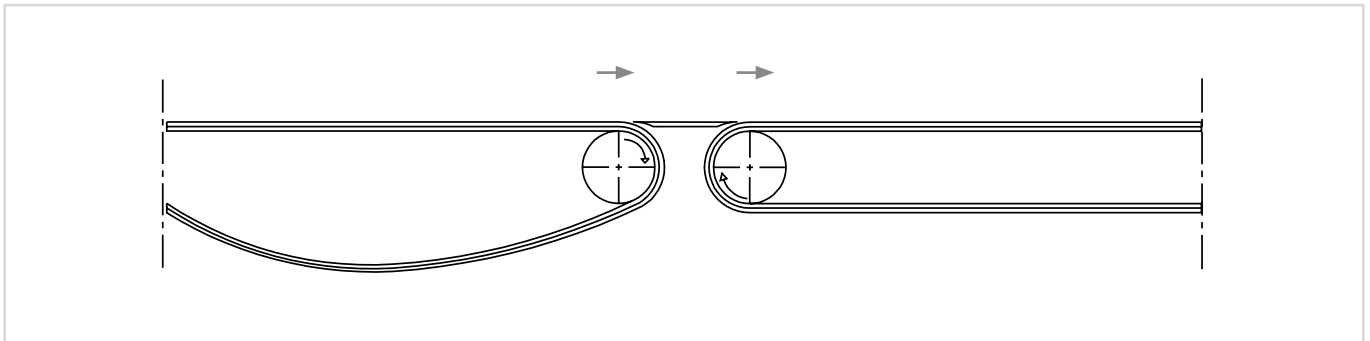

Fig. 3-31

A dead plate is a plate which is placed between two conveyors. See figure 3-31. The back line pressure will push the products onto the dead plate and the next conveyor. If the friction between belt/chain and product is too low compared to the friction between dead plate and product there is a risk that the pattern of the products on the conveyor (e.g. three parallel lines) may be upset by the dead plate.

Because most belts and chains consist of flat modules wrapping around sprockets there will be high and low points on the surface at the dead plate transfer. For this reason a gap (GP) is required between the dead plate and the belt surface to allow these high points to pass through. See figure 3-32.

Note: Curve top belts can be used to reduce this gap. This gap is shown on the diagram to the right. It varies by both belt type and by sprocket size. When determining

this gap size the designer should keep in mind that the dimensions of the belt wrapped around the sprocket are equal to the pitch diameter of the sprocket plus the thickness of the belt. The gap must at least be large enough to avoid interference with the top surface of the belt.

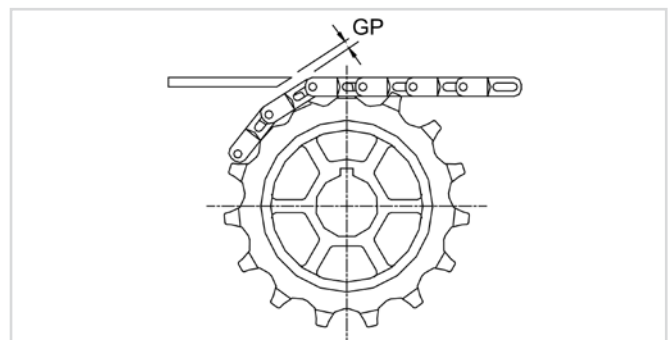

Figure 3-32

Transfer Guidelines

Finger Plates

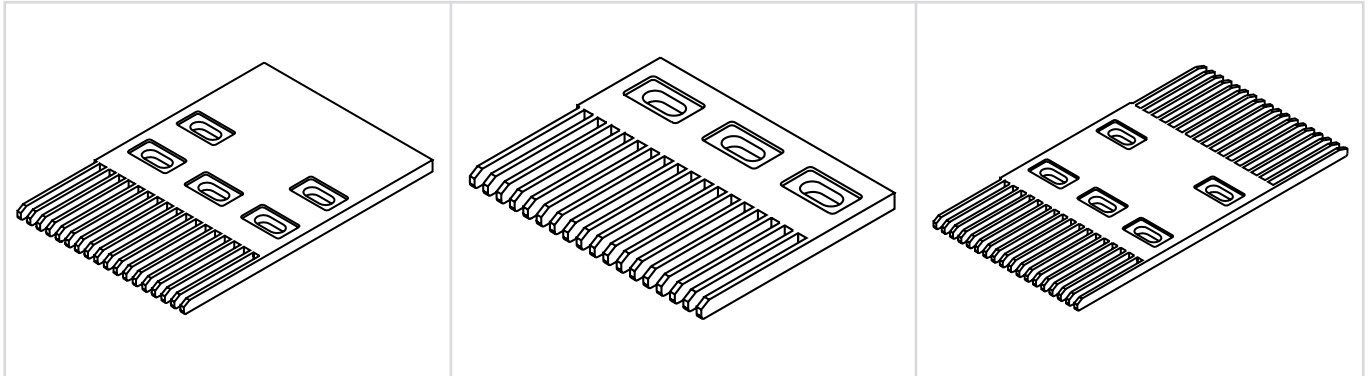

Figure 3-33

Finger plates are a variation of the dead plate. The fingers of the finger plate are inserted between the ribs of the chain/belt, thus eliminating the gap between chain/belt and dead plate. This ensures an even transfer. Most rib belts require the use of their own specific finger plates. These can be found in the uni-chains belt catalog listed as accessories for the appropriate belt.

When mounting finger plates it is important they are allowed to move freely from side to side as the belt expands and contracts. This is why finger plates are supplied with mounting slots instead of round holes. uni-chains recommends using shoulder bolts or other spacers to ensure the bolts do not clamp down too tightly and prohibit the finger plates from being able to move from side to side. See figure 3-33.

Roller Transfer

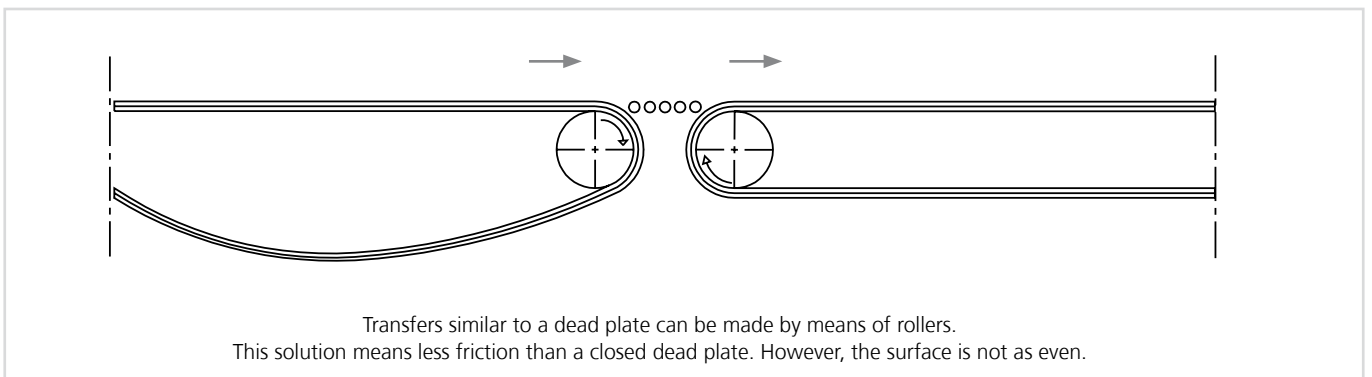

Figure 3-34

Special Design Guidelines

Gripper Conveyors

The most commonly used chain type for vertical transport is uni Grip 1873 (G3, G4, G4L and D) which is a Snap-On chain with rubber inserts on a basic roller chain of steel or stainless steel.

When constructing a uni-Grip conveyor it must be ensured that the conveyor capacity and the infeed speed are consistent.

This can be done in several ways:

1. uni-Grip speed > infeed speed
2. An infeed system that ensures distance between the products
3. Choice of a generous bend radius

It is recommended that the conveyor is constructed so that it is possible to adjust the distance between the uni-Grip chains. This enables for adjustment to allow for changes in product size but also control of pressure on the chain and product.

Typical applications for gripper chains could be as follows: (see diagrams below)

- To invert a product
- To allow for a passageway
- Holding a container up-side-down for washing and rinsing
- Elevating or lowering products from one level to another

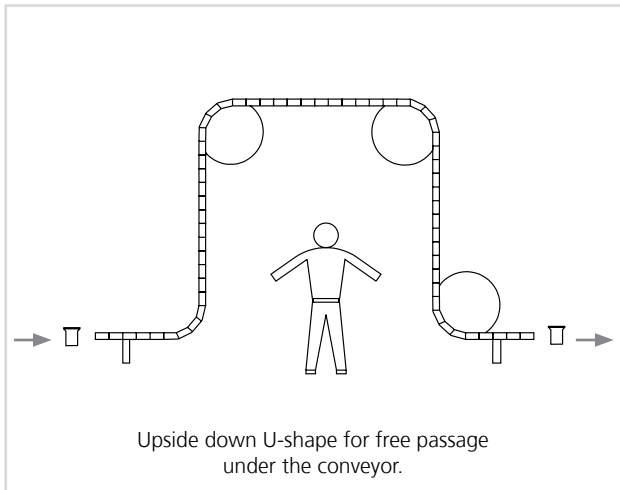

Figure 3-35

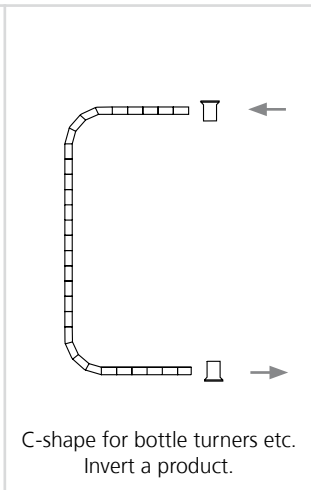

Figure 3-36

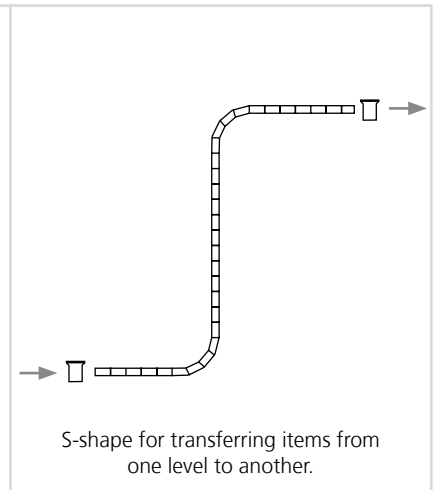

Figure 3-37

Alpine (Serpentine) Conveyors

Serpentine conveyors are used for transporting products from one level to another. The advantages of the serpentine conveyor are that it is very compact yet with a large capacity because it can be utilized both in the width and the height. See figure 3-38.

Due to the large capacity these conveyors are often used as buffers in the product flow through a facility to avoid production interruptions, such as between a filling machine for coffee and the packing machine.

It is necessary to use turn discs in all 180° curves.

The discs should be tilted so that they are flush with the inclination of the plane to which the products are conveyed. This means that it is necessary to insert a break on the infeed to the discs. At a minimum this break must be



Figure 3-38

a distance equal to the disc radius from the disc shaft. The chain length in a serpentine conveyor normally should not exceed 25 m (82 ft) between the drive stations.

Special Design Guidelines

Pasteurizers & Blanchers

These are heated conveyors that work in an environment with high temperatures, mainly with belts.

They include:

- Pasteurizers
- Blanchers
- Can heaters
- Cookers
- Shrink-wrapping machines
- Others

Very often this kind of conveyors is used for continuous food processing. They are usually long conveyors with high product loads.

Construction

Conveyor Frame

The frame of a conveyor is normally of stainless steel, often wearstrips are not used because of the poor cleanability in conveyors with unpacked products like blanchers and cookers. The frame also must allow for thermal expansion in the belt. Refer to the calculation section for details on calculating thermal expansion.

Dimensional precautions

Measures must be taken to allow for the thermal dimensional changes in the frame laterally and longitudinally. In the width the frame has to be fitted so that it allows for the thermal expansion plus a clearance of minimum 15 mm (0.59 in.) to allow for tolerances. Longitudinally the setup has to allow for the thermal elongation of the belt, this means that there has to be a certain take-up in the return.

Note: By adding steel reinforcement links the thermal length change decreases, and the take-up problems will be reduced.

For more calculations on tensile strengths, sprocket requirements and shaft requirements, refer to the belt calculations section (pages 65-70).

Vacuum Conveyors

The uni-chains product range offers various belts and chains with vacuum holes. Using vacuum ensures an equal pressure across the entire width of the belt. Some belts currently have vacuum holes pre-molded into the belt. Refer to the uni-chains belt catalog for the complete range of belts with molded vacuum holes. Other locations and sizes of holes can be manufactured upon request in any closed top uni-chains belt or Slat Top chains.

Vacuum conveyors are typically used for inclined conveying of empty containers such as cans. Other products and conveyor applications such as overhead conveying are also suitable for vacuum conveying. Contact uni-chains engineering for vacuum percentage open area per your requirements.

Special Design Guidelines

Long Conveyors

The requirements for long conveyors have increased recently, especially within the automobile and tourist industries.

The great advantage of long conveyors is the reduced need for transfers between conveyors. Transfers often create problems involving increased costs. Another advantage is the reduced number of driving stations, reducing the construction costs of the conveyor.

When building long conveyors you should pay great attention to the increased risk of pulsation.

Another important aspect is the belt elongation which can be considerable.

Definition of a long Conveyor

Normally, a straight running conveyor is defined as being long if the total length exceeds 20 m (65 ft). For a sideflexing conveyor the length is 12 m (39 ft). If these lengths are exceeded, the risk of pulsation increases. For ways to reduce pulsation, refer to slip-stick/surging/pulsation on page 39.

Belt Elongation

There are several ways to absorb the belt elongation. Below the two most common methods will be described.

Method 1

The elongation is absorbed by a catenary sag on the return. The return belt must run on rollers with a given distance, the elongation will then be distributed between the rollers in the catenary sag. It is important, when applying this method, to ensure that the distance between the first and the second roller is the largest because the belt weight must be the largest at that spot. This ensures that the catenary sag will be located there to provide a good engagement between belt and driving sprockets.

Method 1 is relatively simple and economical but it has some disadvantages. One is that it requires a large construction height. Another is the risk that the belt between the rollers will start to oscillate and thus increase the pulsation (to address this the roller spacing should vary from one roller to the next). Furthermore noise may also be generated.

Method 2

In this method the elongation is absorbed by means of air cylinders mounted either on the side of the conveyor or between top and return.

Length of stroke of the cylinders must be minimum 0.5 x total belt elongation.

The advantages of this method are that it is possible to build a conveyor with a relatively low construction height. Furthermore the risk of pulsation caused by vibrations from the return is reduced because this is "tight" due to the cylinders.

Method 2 is considerably more costly than method 1, so it is recommended in each case to consider thoroughly what is necessary for the conveyor in question.

Contact uni-chains engineering for further information.

Special Design Guidelines

Carousel (endless) Conveyors

In an endless conveyor there is no return, thus half of the costs for chain/belt can be saved. Endless conveyors are possible only with sideflexing chains/belts. See figure 3-39.

With Transfer Plates

A normal vertical drive with a combined sag/return transfer zone.

This type of conveyor is characterized by the driving sprocket being placed under a dead plate together with a sag or a tensioning device to absorb the belt elongation. See figure 3-40. If the minimum transfer length is required a nosebar can be used.

Thermal Expansion and Contraction

Any material will expand when heated. We know it from the liquid in a thermometer. You may also have heard about railway rails that expand during extreme summer temperatures, hampering the traffic. When constructing conveyors the designer and fabricator should also allow for thermal expansion and contraction. Plastic will expand at a much greater rate than steel and considerations must be made for this.

Temperature changes can be caused by:

- 1) Variations in the surrounding temperature (day/night or summer/winter)
- 2) Heating because of friction during operation (start/stop)
- 3) Cold or hot processes that the chain/belt encounters on the line
- 4) Heat radiation from surrounding processes

Plastic material is a poorer heat conductor than steel. It takes longer to heat and cool plastic materials than e.g. steel. This should be taken into account at very short heat/cold influences. Refer to the calculation section for calculation of the amount of thermal expansion or contraction.

Wearstrips, Wearparts and extruded Profiles

The thermal expansion of wearstrips, straight parts and extruded profiles can be accommodated by dividing the total length into smaller sections. The thermal expansion of a given section can be calculated and enough space must be left for the surrounding sections.

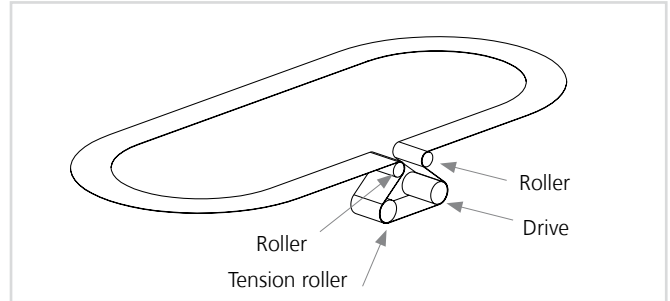

Figure 3-39

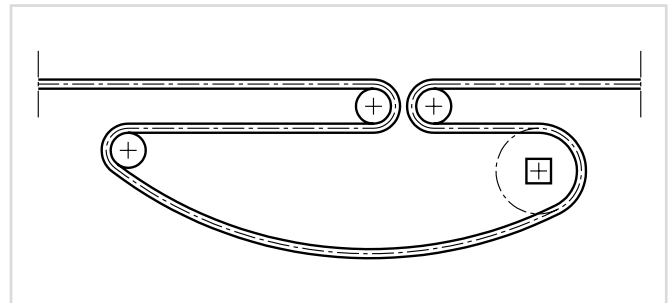

Figure 3-40

It is important that the wearstrip is fastened only at the end closest to the idler end of the conveyor. Thus the expansion will take place in the travel direction of the chain/belt. In the joints between the plastic wearstrips it is necessary that the chain/belt is supported. One way to do this is to cut the joints at a 45° angle to provide some overlapping of the gap between the strips. Another is to use a "tongue and groove" arrangement as shown in figure 3-41.

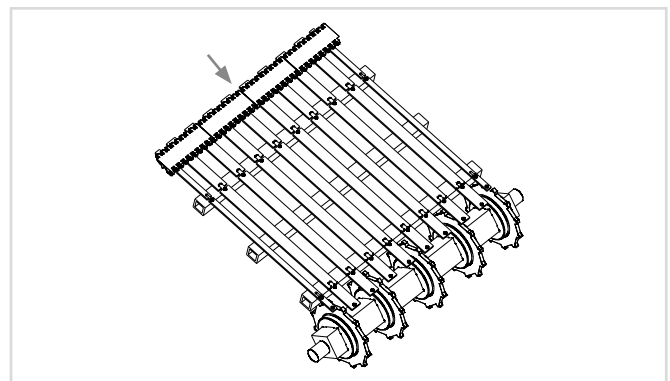

Figure 3-41

Note: To calculate the expansion in the width of a belt, the same formula can be used, but with the width instead of the length.

Special Design Guidelines

Expansion due to Water Absorption

All plastic materials absorb water from the surroundings, but very often it is not a major factor – except when dealing with Nylon (PA) material. With Nylon there can be a considerable change in dimension depending on the environment where the part is placed. The absorption of water causes the plastic part to swell and thus leads to a

volume increase. The chart below shows the dimensional expansion of different materials due to moisture absorption. Please note that the expansion shown here does not necessarily translate into belt/chain dimensions as there are many other factors involved.

| Material | Water Absorption ISO 62 / ASTM D570 | | Linear Dimensional Expansion Water Absorption | |
|-----------|--|------------------------|--|------------------------|
| | Equilibrium 23°C / 50% RH (%) | Saturation 23°C (%) | Equilibrium 23°C / 50% RH (%) | Saturation 23°C (%) |
| PP | 0.02% | 0.03% | 0.01% | 0.01% |
| PE | 0.02% | 0.03% | 0.01% | 0.01% |
| POM | 0.22% | 0.80% | 0.10% | 0.37% |
| PA6 | 2.80% | 8%-10% | 1.05% | 3%-3.38 |
| PA66 | 2.50% | 7%-8.5% | 0.95% | 2.7%-3.2% |
| PA6.6-GFH | 2.00% | 6.00% | 0.80% | 2.36% |
| PBT | 0.20% | 0.50% | 0.09% | 0.22% |
| PBT-GR | 0.15% | 0.40% | 0.07% | 0.19% |
| NBWR | 0.20% | 0.60% | 0.08% | 0.24% |

Slip Stick/Surging/Pulsation

A modular belt can be perceived as a spring, i.e. the belt can stretch a little in each pitch. In long belts this elongation is of great importance and must be taken into account. Imagine that you pull a floating belt. Theoretically the belt will begin to move at both ends at the same time.

However if the belt slides on a support, the belt in the idler end will not begin to move immediately when the belt is driven. The static friction between the belt and the support will retain the belt for an instant and will not move until the tension is high enough to overcome this static friction.

When the motor starts the belt at the drive end will move immediately, but the belt toward the idler end will be held back until the pull has overcome the static friction. When the belt begins to move, it will not be a smooth start because of the spring effect in the belt and because dynamic friction is lower than the static friction. These built up forces at each pin are released once this force of friction is overcome and causes pulsation.

Ways to Overcome Pulsation

As described above the friction is one of the reasons for the pulsation. So it is very important for the friction to be as low as possible between the belt and the support. To reduce friction uni-chains recommends the use of

wearstrips in a high density material (PEHD/UHMWPE). This material has a lower friction than stainless steel that is often used in conveyors. It should also be noted that surging is more prevalent at slower speeds, so increasing speed is another way to reduce surging.

There are two options: To run the belt on a whole PEHD/UHMWPE plate to support the entire belt or to run it on wearstrips. Regardless of the method it is important to mount the support properly (see wearstrip support page). There should be no sharp edges in the joining points of the profiles where there is a risk of increased friction that will cause an uneven pull in the belt. It is recommended to chamfer the edges of the profiles.

It is also important to address the return of the belt when looking at ways to reduce pulsation. Often rollers are used to support the belt on the return, causing very little increase in friction. However, under certain conditions of speed and tension, these catenaries can reach their natural frequency and cause a vibration that can be carried up to the carryway. One way to address this harmonic vibration is to vary the spans of the catenaries on the return. The best practice is to add a partial slider return along with the rollers of at least 2/3 the length of the conveyor. This added resistance of the slider will help to hold back surging and dampen the vibrations of the catenaries.

Special Design Guidelines

Slip Stick/Surging/Pulsation

If a conveyor is required to be totally free of pulsation, it is often necessary to furnish the idler end with an adjustable tensioning system. This retention must be large enough to remove the elasticity of the belt totally. The pulsation of the belt will be non-existent because the belt is no longer elastic but rather a rigid item. The size of the retention force varies with the length of the conveyor. Normally the retention power is set to 75% of the power required to pull the unloaded belt.

Chordal Action

Chordal action is a type of pulsation in the belt or chain's linear velocity that results from the sprocket rotating at a constant speed while the belt hinge follows the chords. Figure 3-44 shows the movement of the belt along the sprocket. In applications where product tippage and/or slippage can be an issue or where constant speed is critical the chordal action should be taken into account when selecting a chain/belt and sprocket combination.

The greatest amount of chordal action occurs with a chain that has a large pitch and a small diameter sprocket. A large sprocket diameter and a small chain pitch will result in a small chordal action. There are reasons, however, that a large sprocket and small chain pitch are not used. If there is a transfer, a nosebar or a small sprocket/roller are preferable to create a small gap between the transfer. Or more simply a lack of space could limit the use of a large sprocket. Figure 3-42 and figure 3-43 are graphs explaining the relationship between number of teeth and chordal action.

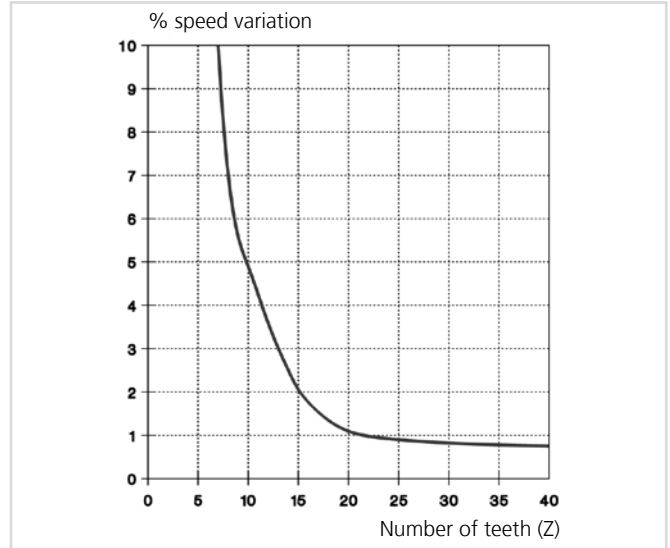

Figure 3-42

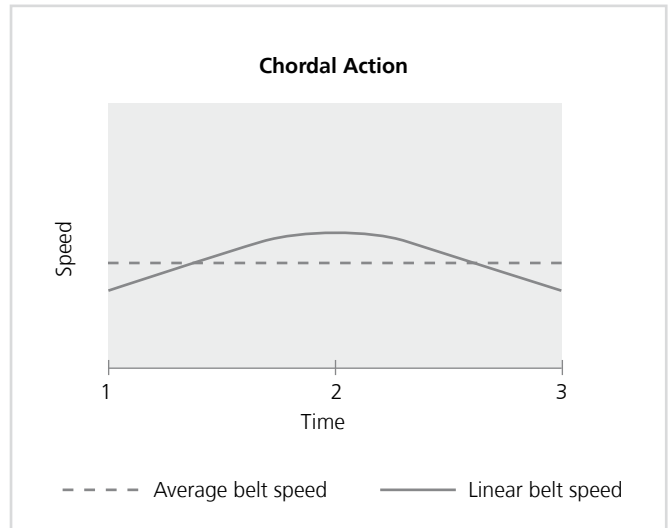

Figure 3-43

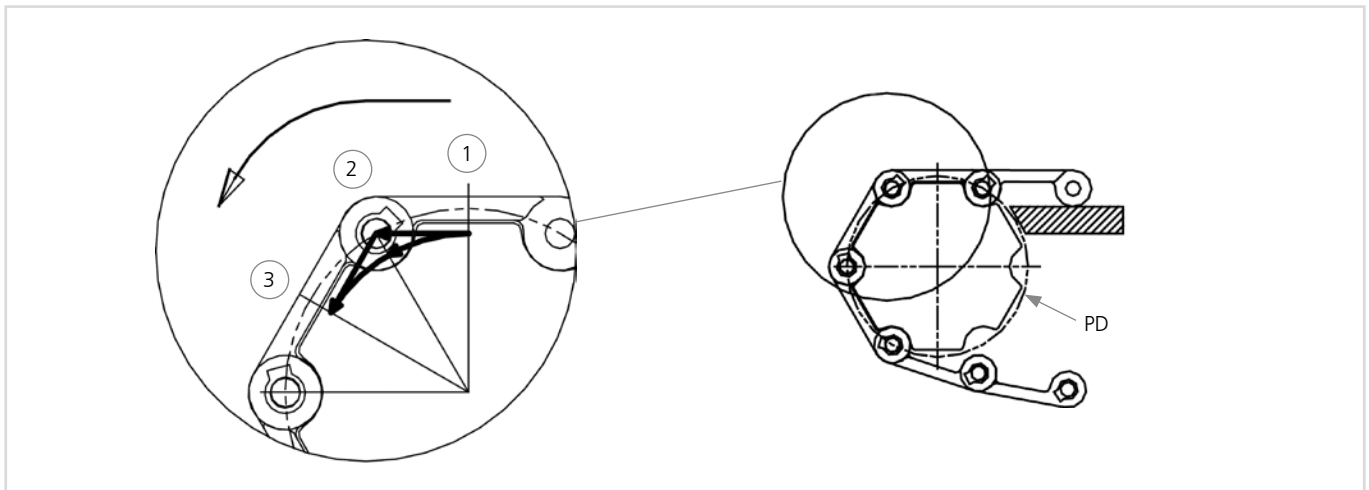

Figure 3-44

Wearstrip and Support

Straight running Chains, single Tracks

Some details for the wearstrips and supports

- Straight profiles can consist of one or several blocks with machined tracks. See figure 3-45, figure 3-47 and figure 3-48.
- The profiles must be fixed to the conveyer frame.
- The typical length of a straight profile is 3 m (10 ft).
- The shape of the track depends on both the type of chain and the application it is designed for.

- Straight running chains can be supported with rollers on the return section. Figure 3-46. The distance between the rollers has to vary if there is more than one roller on the return section.

Below are some cross-sections of profiles for listed straight running chains.

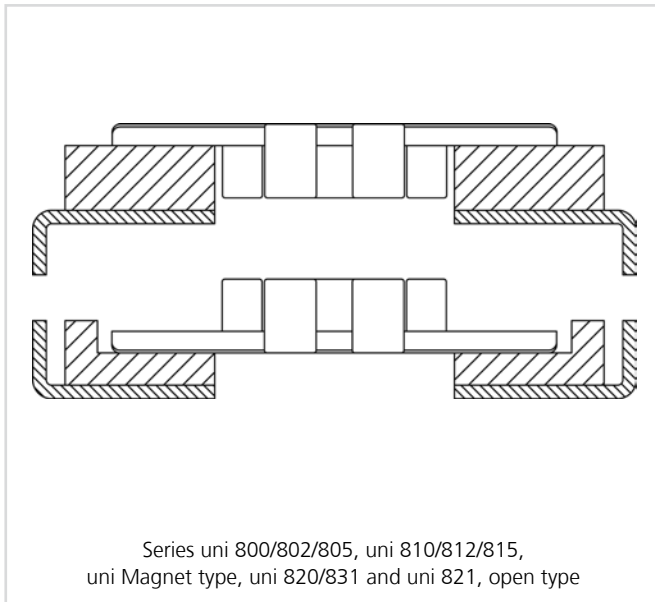

Figure 3-45

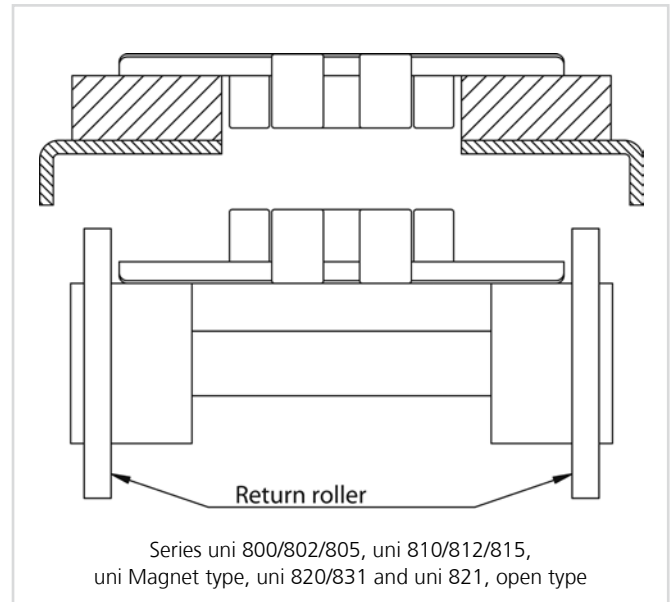

Figure 3-46

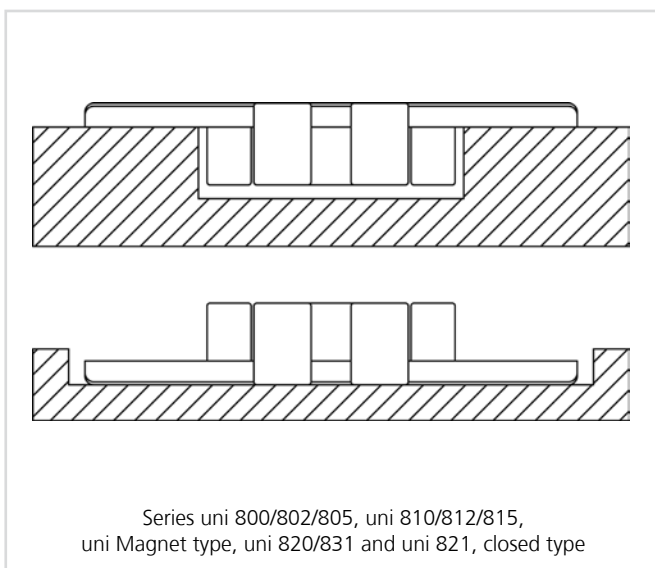

Figure 3-47

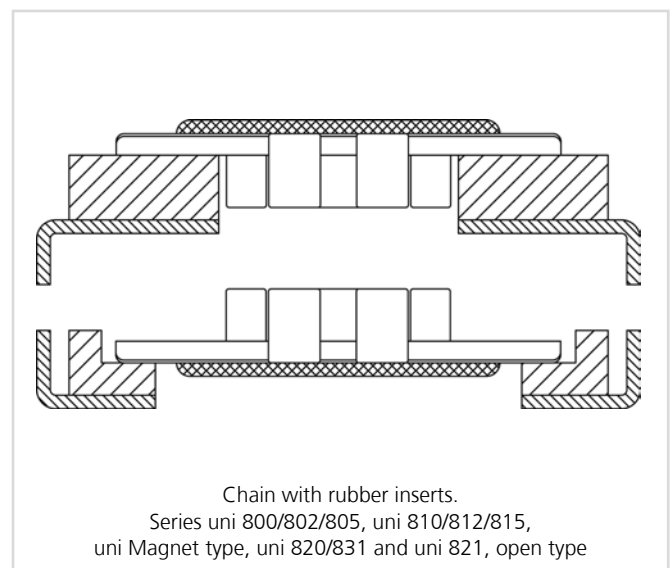

Figure 3-48

Wearstrip and Support

Straight running Chains, multiple Tracks

Some details for the wearstrips and supports

- See straight running chains, single tracks on page 40.
- Recommended distance between chains on carry and return min. 2 mm (0.08 in.). Figure 3-49, figure 3-50 and figure 3-51.

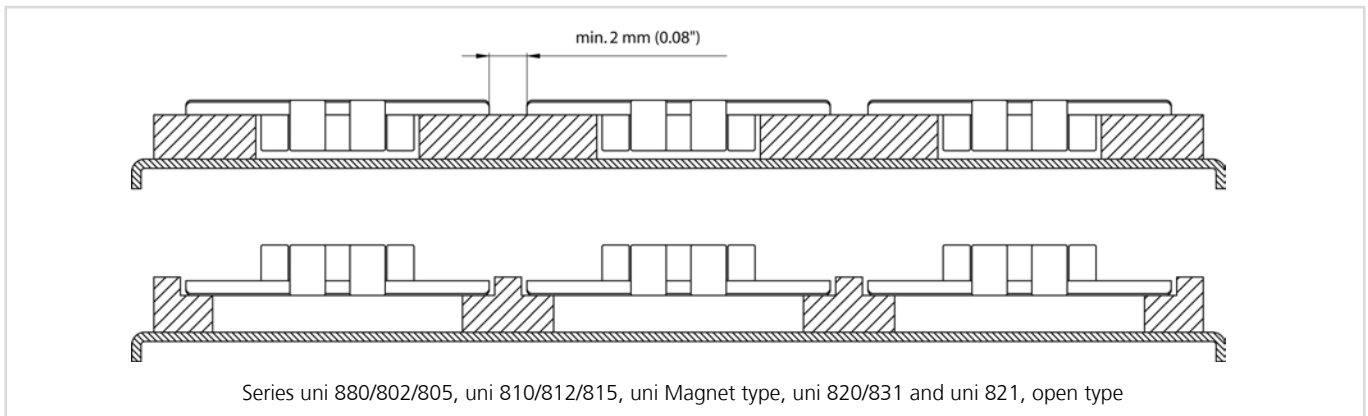

Figure 3-49

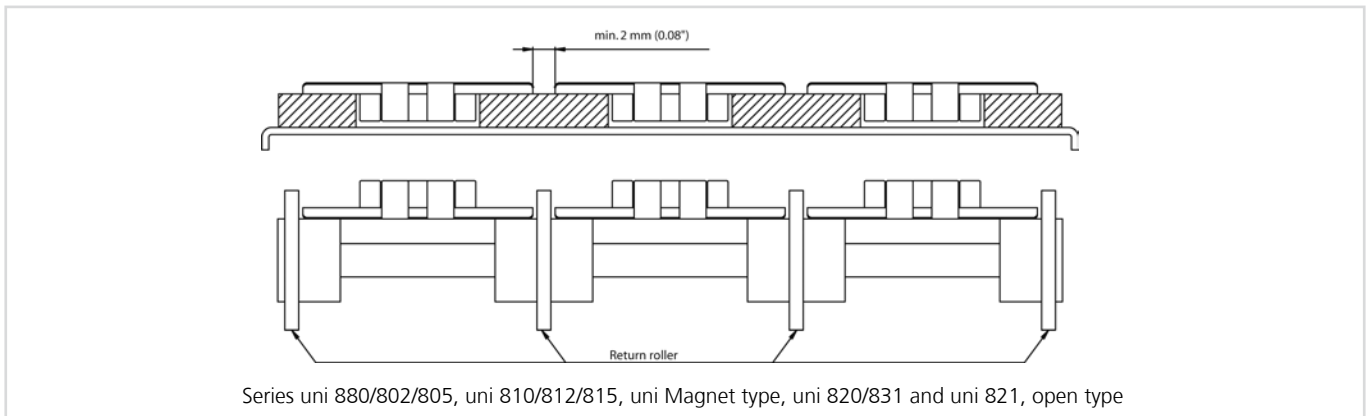

Figure 3-50

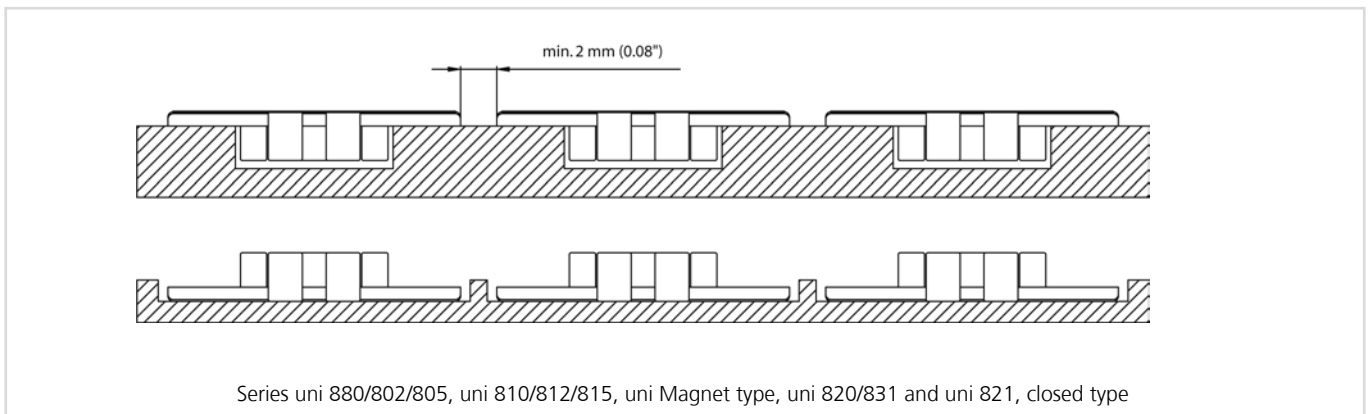

Figure 3-51

Wearstrip and Support

Sideflexing Chains, single Tracks

Some details for the wearstrips and supports

- The profiles must be fixed to the conveyor frame.
- The shape of the track depends on both the type of chain and the application it is designed for.
- The carry and return profiles for Tab-chains have similar shaped tracks. Figure 3-52 and figure 3-53.
- For certain bevel type chains it is necessary to support the chain on the return, with a return plate under the chain. Figure 3-54 and figure 3-55.
- Often there are no returnways. Instead the chain runs freely or is supported by rolls or planes. Figure 3-46.

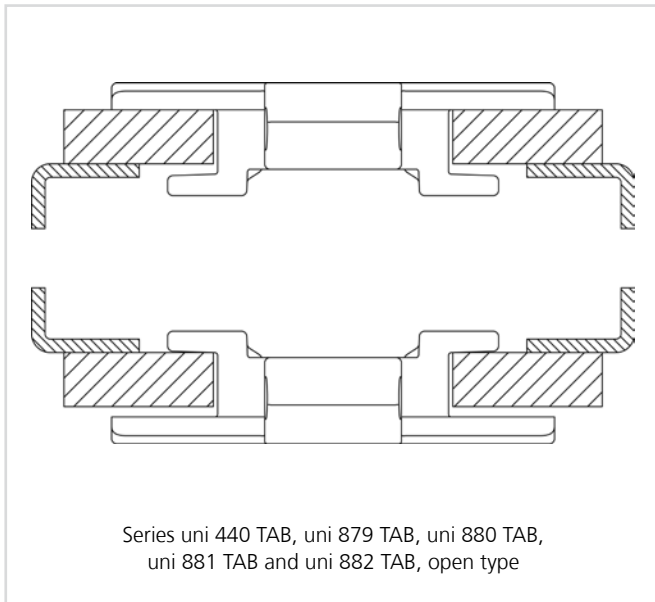

Figure 3-52

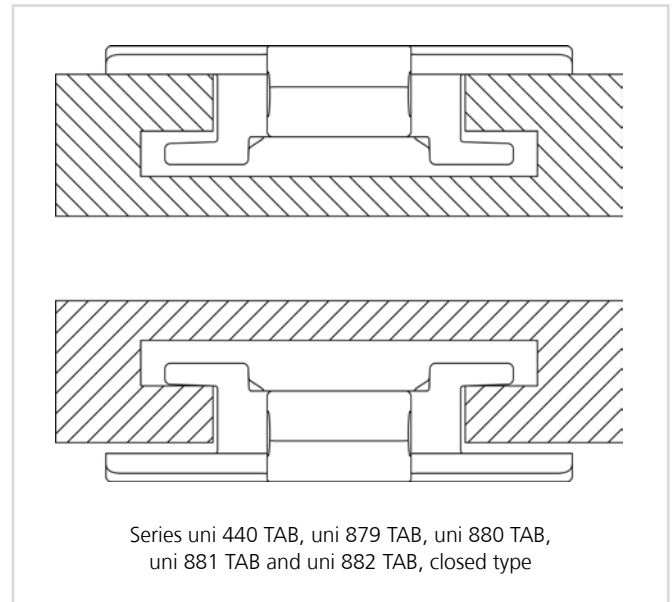

Figure 3-53

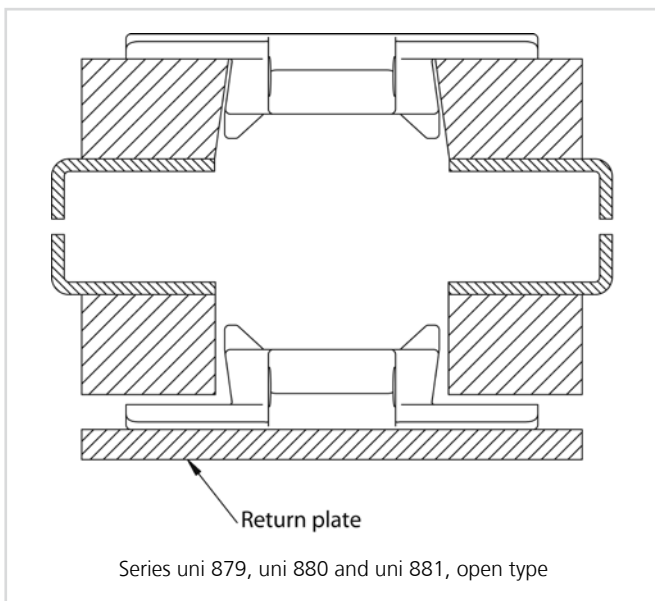

Figure 3-54

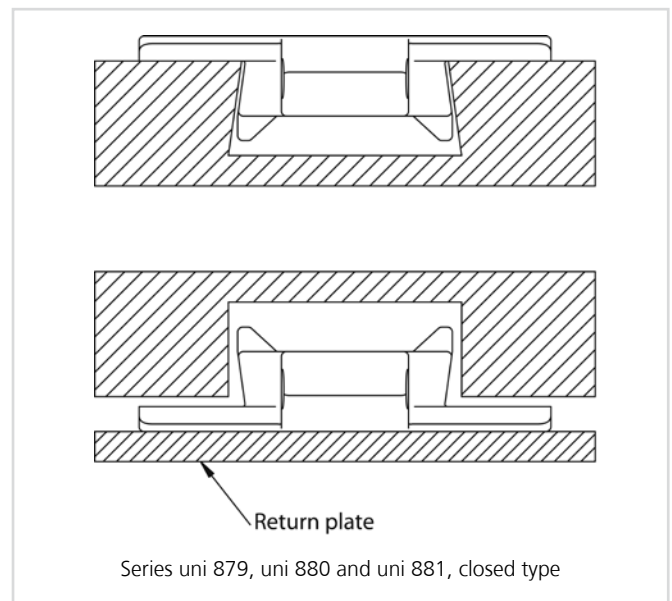

Figure 3-55

Wearstrip and Support

Sideflexing Chains, multiple Tracks

Some details for the wearstrips and supports

- See sideflexing chains, single tracks on page 42.
- Minimum distance between chains on carry and return is min. 2 mm (0.08 in.). Figure 3-56, figure 3-57 and figure 3-58.

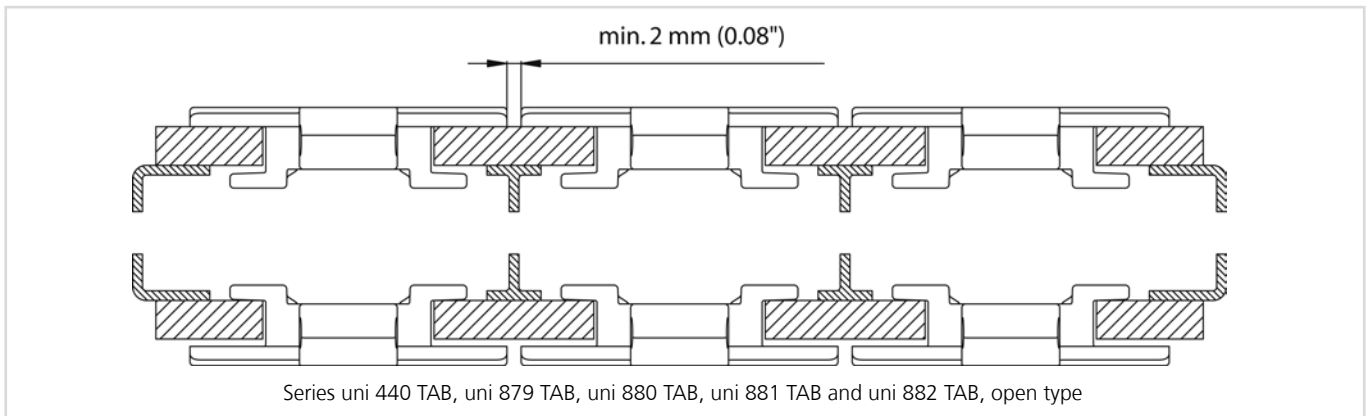

Figure 3-56

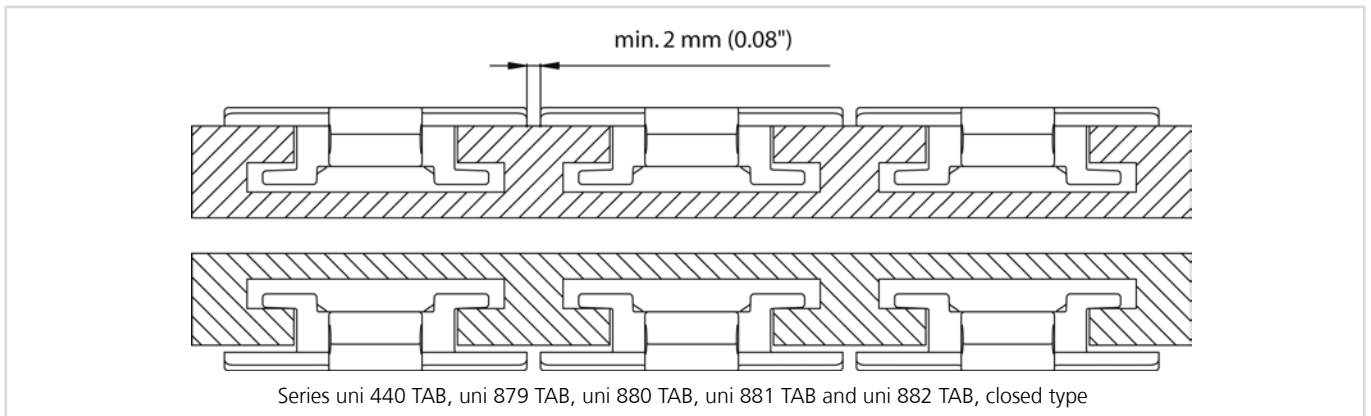

Figure 3-57

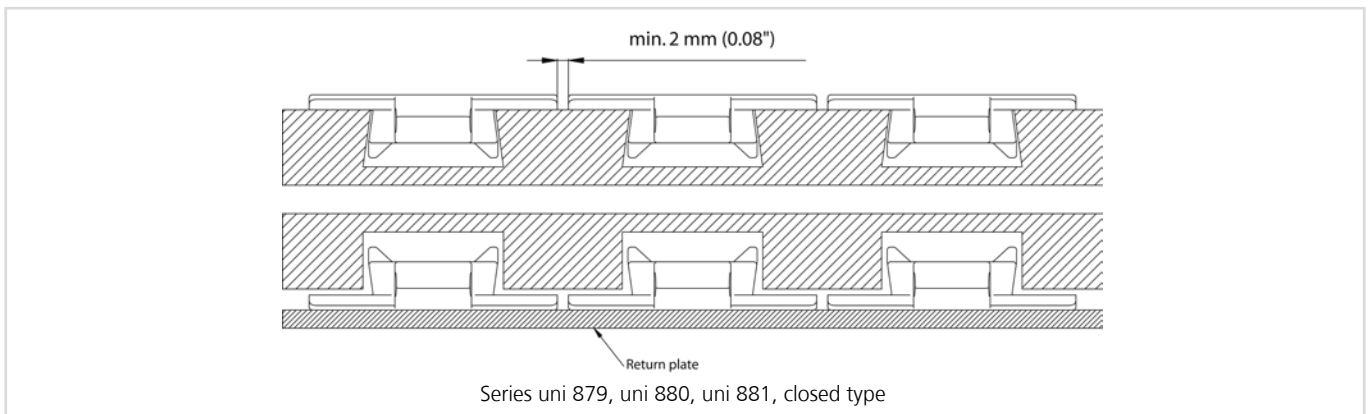

Figure 3-58

Wearstrip and Support

Sideflexing Super Flex Chains, Open version

Some details for the wearstrips and supports

- Super flex chains can be lifted out of the carry wearstrips without the use of any tools.
- The super flex shoe ensures that the chain is always held totally flat against the wearstrips in the curve.
- The design reduces vibrations.

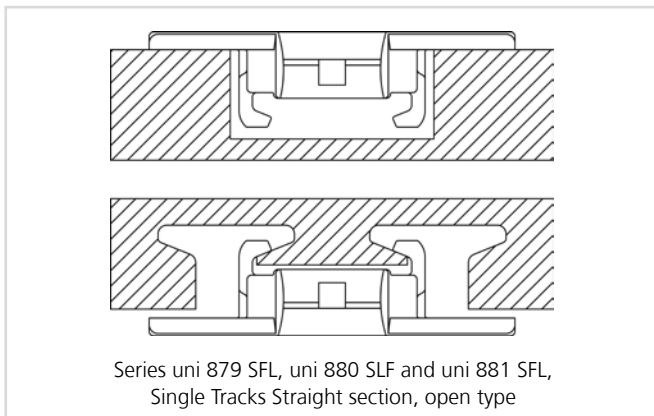

Figure 3-59

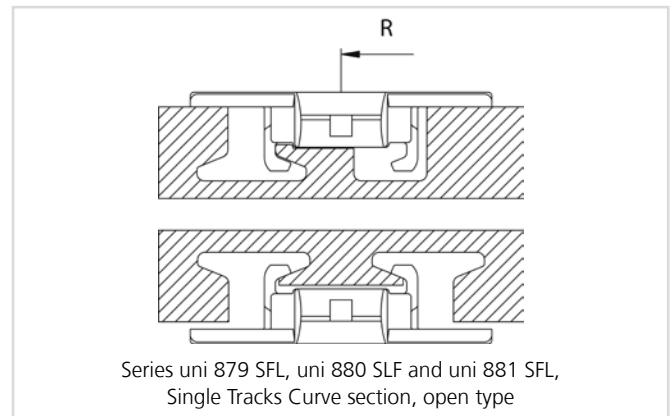

Figure 3-60

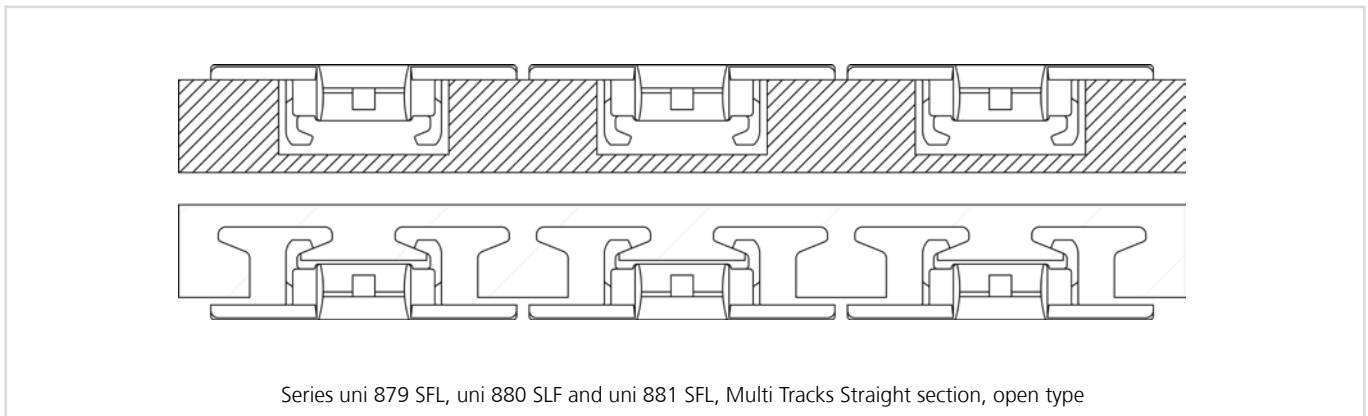

Figure 3-61

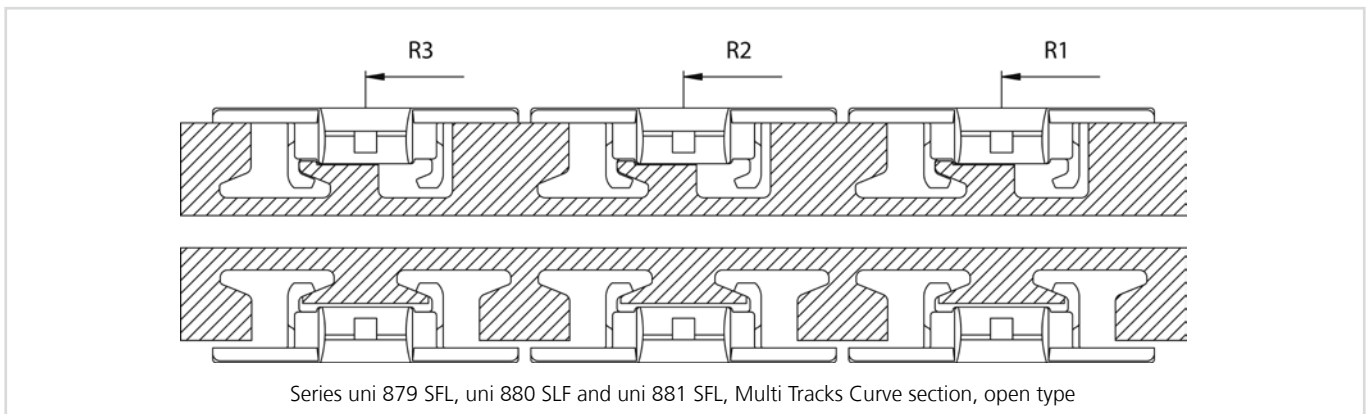

Figure 3-62

Wearstrip and Support

Sideflexing Super Flex Chains, Closed version

Some details for the wearstrips and supports

- Super flex chains can be lifted out of the carry wearstrips without the use of any tools.
- The super flex shoe ensures that the chain is always held totally flat against the wearstrips in the curve.
- The design reduces vibrations.

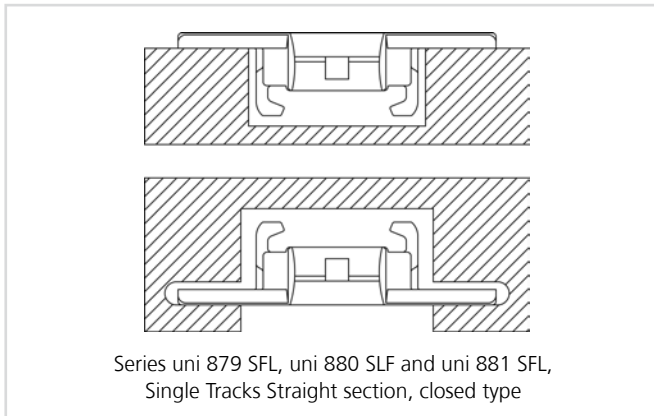

Figure 3-63

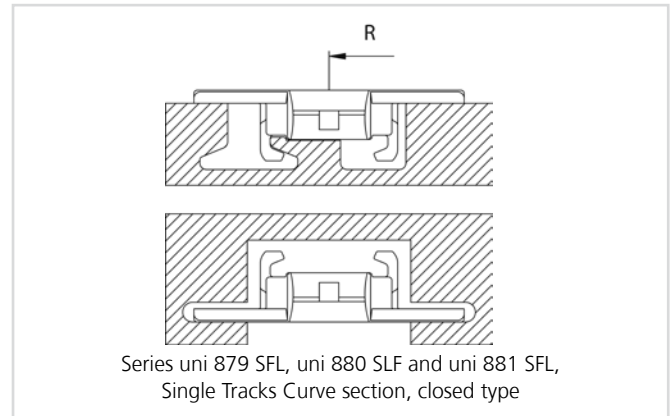

Figure 3-64

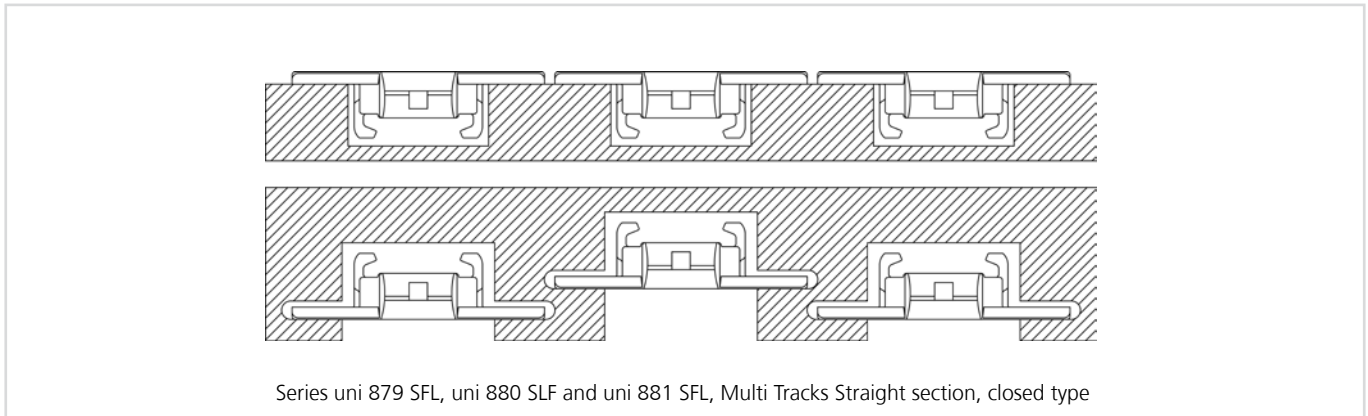

Figure 3-65

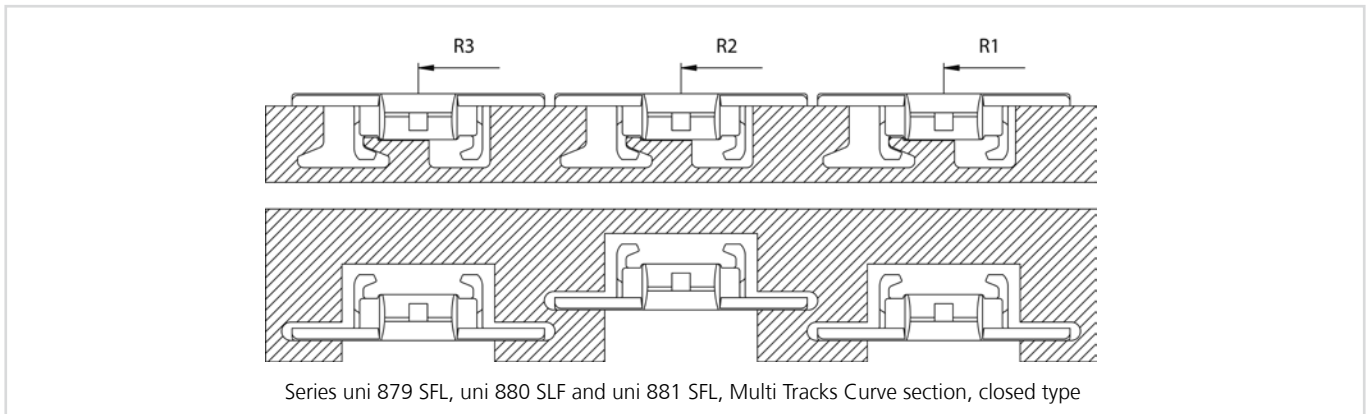

Figure 3-66

Wearstrip and Support

uni Flex Chains

The construction of a carryway for uni Flex chains varies, depending on the chain type and application. Figure 3-67 shows two different types of supports for uni Flex Chains, fishbone/chevron pattern and serpentine configuration. The wearstrips and in a fishbone or serpentine fashion so that wear is placed evenly over the chain. See figure 3-67.

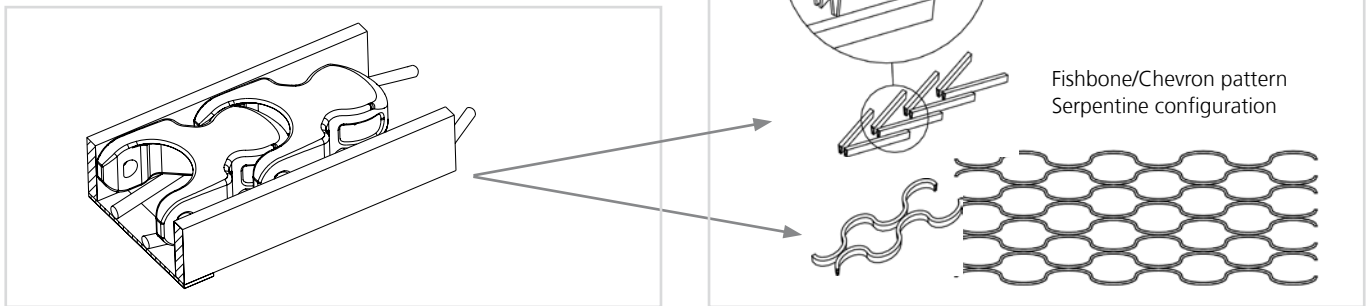

Figure 3-67

Note: The drawing only suggests a placing of wearstrips which can ensure an even wear on the chain.

Wearstrip and Support

Belt Carryways and Returnways

Belt Carryways

The design of the carryway must be made taking the following factors into account:

- Horizontal or incline conveyors
- Belt type
- Load
- Temperature conditions
- Abrasive environment

Carryways for belts can be made in many ways. Below are different examples of how carryways can be built based on design requirements. In all cases, due to the possible expansion of the wearstrip materials, care must be taken, when mounting carryways that the materials are free to expand and contract without interfering with conveyor operation.

Parallel Wearstrips

For belt systems with light loads and low wear the carryway can be constructed see figure 3-68.

“Fishbone” or “Chevron” Pattern

For belt systems with rather heavy load or positioned in high wear applications the carryway can be constructed with flat strips in a V-position as seen in figure 3-69 to distribute the wear evenly on the entire belt. This is sometimes referred to as a “fishbone” or “chevron” pattern. A gap of 10.2 mm (0.4 in.) or greater is recommended at the points and the angle between the points should be between 20° and 60°. A typical distance measured between two parallel strips is 51 mm (2 in.) and should not exceed 127 mm (5 in.). Other methods for distributing wear on the bottom of the belt are shown in figure 3-70.

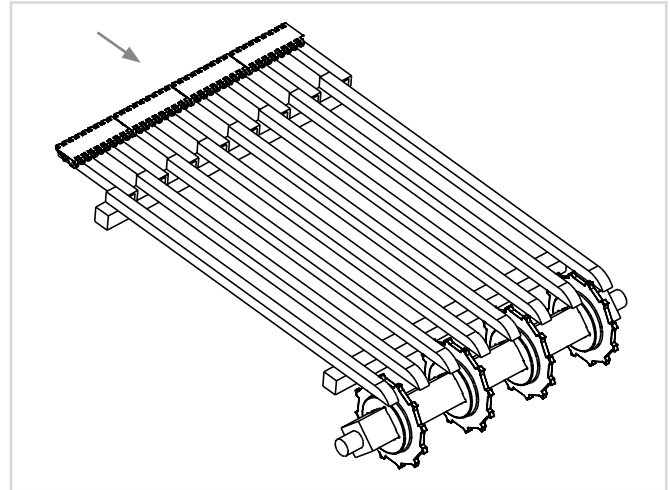

Figure 3-68

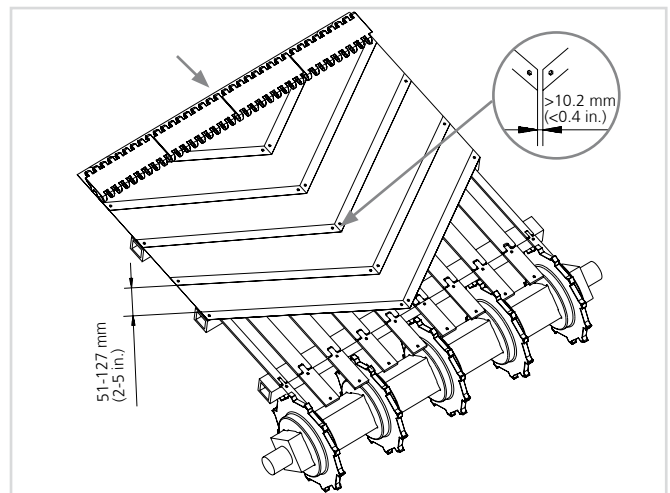

Figure 3-69

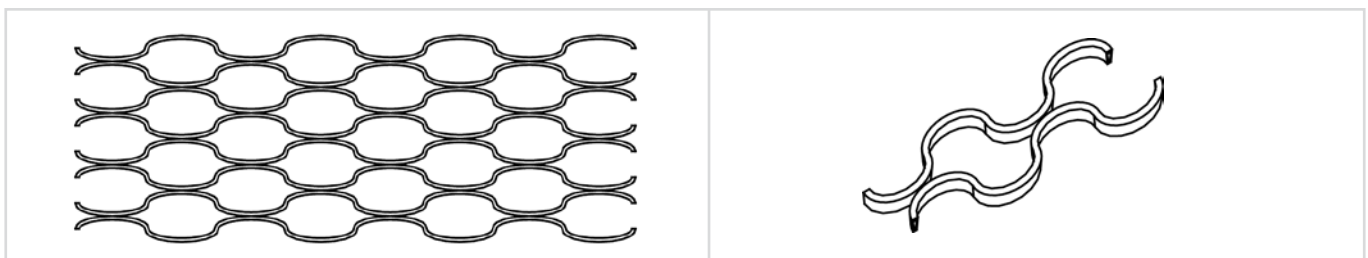

Figure 3-70

Wearstrip and Support

Tracking & Control Systems for Sideflexing Belts

The three basic Methods

There are three basic ways that a sideflexing belt can be guided around the curves and in the straight sections.

- Held down on the top surface with wearstrips
- Guided using edge tabs
- Guided using bottom tabs

All of these methods have advantages and disadvantages as noted below. Each uni-chains belt type has its own wearstrip guidelines and dimensions. Consult the individual uni-chains belt catalog pages for specific details.

Top Surface Hold-Down Method

This is the easiest method and it is the most forgiving with regard to fabrication tolerances of the conveyor. This method simply relies on a wearstrip on top of the belt to prevent it from pulling up and out of the curve. In this case the guide clearance only needs to be small enough to ensure that the belt edge is captured. So a larger amount of the belt edge being held down allows for a more generous guide clearance. This method also gives a large bearing surface contact area on the inside edge which is preferred for high speed and high wear applications. The disadvantage to this method is that the usable belt surface area is reduced because of the hold-down wearstrips on top. Figure 3-71 is an example of a uni Flex SNB belt using this tracking system.

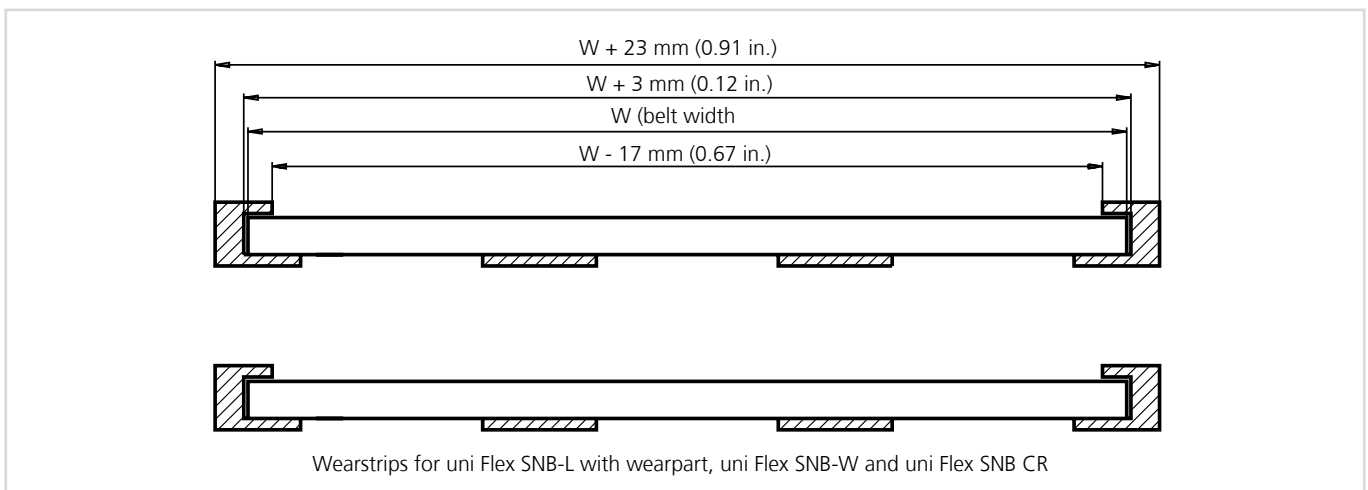

Figure 3-71

Wearstrip and Support

Tracking & Control Systems for Sideflexing Belts

Edge Tab (O-TAB) Hold-Down Method

This method uses edge tabs (called O-tabs) to guide the belt. In this case the wearstrip is holding down the edge tab, not the top surface of the belt. So the advantage of this method is that the wearstrips can be below the surface of the belt which allows the use of the entire belt width or even allows products to overhang the belt edges. The disadvantage of this method is that the guide

clearance is very critical because the wearstrip must properly engage the extended portion of the tab. It must be small enough to engage the tab but not so small that it compresses the belt. Also, because of the tab feature the bearing surface on the inside edge is reduced which decreases wear resistance. Figure 3-72 is an example of a uni Flex SNB WO with an integrated outer O-Tab.

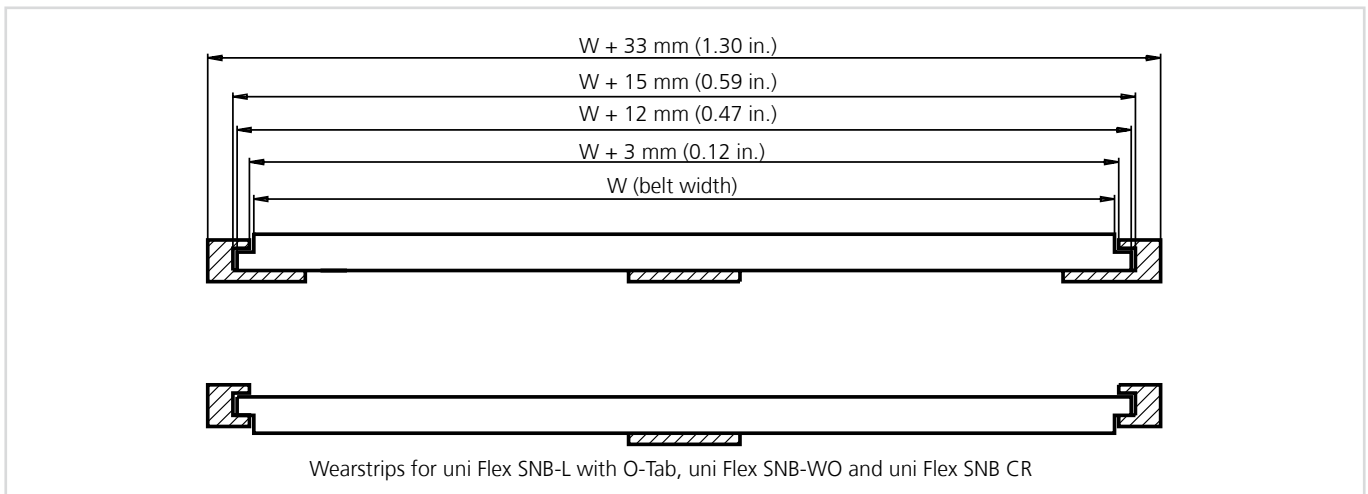

Figure 3-72

Note: The belt and/or the conveyor frame will expand when the temperature rises. Precautions should be taken to ensure correct tracking and belt control.

Bottom Tab Hold-Down Method

This method uses hold-down tabs on the bottom of the belt to prevent it from pulling up and out of the curves. An advantage of this method is that the tabs are larger than edge tabs and allow for more tolerance on the guide clearance. Also, this method does not require wearstrips on the edge leaving it open for side transfers or parallel lanes. The disadvantage is that the tabs can easily catch on any susceptible areas on the conveyor and, because of their size, have a tendency to break if

exposed to catch points. uni-chains does not recommend bearing the radial load on these tabs in the curve. They should only be used to resist the upward force in the curve. It is recommended to use inside edge wearstrips in the curve to bear the inward radial load. Below is an example of Flex SNB with bottom tabs. This can be done with tabs on one or both sides. The example shows a tab on one side.

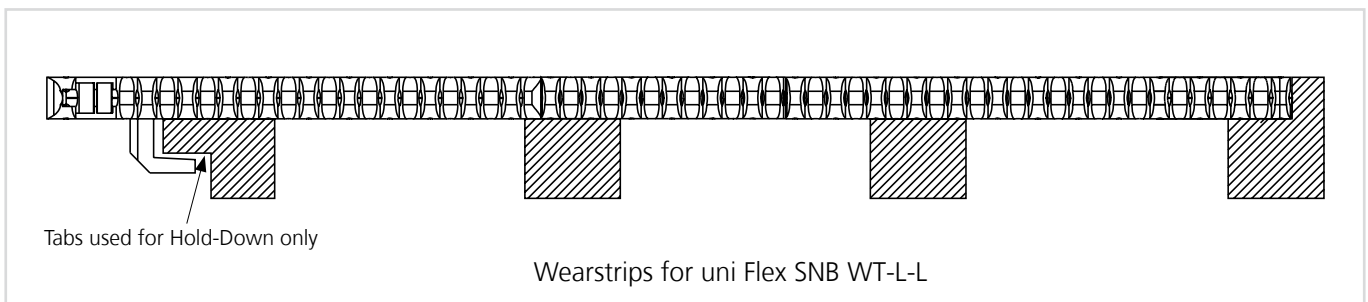

Figure 3-73

Note: The belt and/or the conveyor frame will expand when the temperature rises. Precautions should be taken to ensure correct tracking and belt control.

Wearstrip and Support

Returning Belt with Product Supports

Special considerations must be made when returning a belt with product supports. See figure 3-74. Because the product supports extend above the surface of the belt, when it is running upside down it cannot roll over rollers or slide on wearstrip like a flat top belt can. The most common return method is to indent the product supports on the edges so the belt can be supported on the edges on the return. So on the return the belt is supported by a roller, wearstrip, or shoe on the edge and the product support is left to hang freely in the center. If the belt is very wide it may be necessary to include a notch or notches across the width of the product support so more return supports can be used at those points. The need for center support notches is dependant on the belt rigidity which is a function of its construction as well as the belt and pin materials.

Another method of returning belts with product supports is the use of bottom tabs. With tabs the belt is returned in the same way as a Slat Top chain with tabs. In this case the product support is able to extend the full width of the belt because the edges are not needed for support. Only certain belts types are available with bottom tabs. Please consult the uni-chains belt catalog for more information.

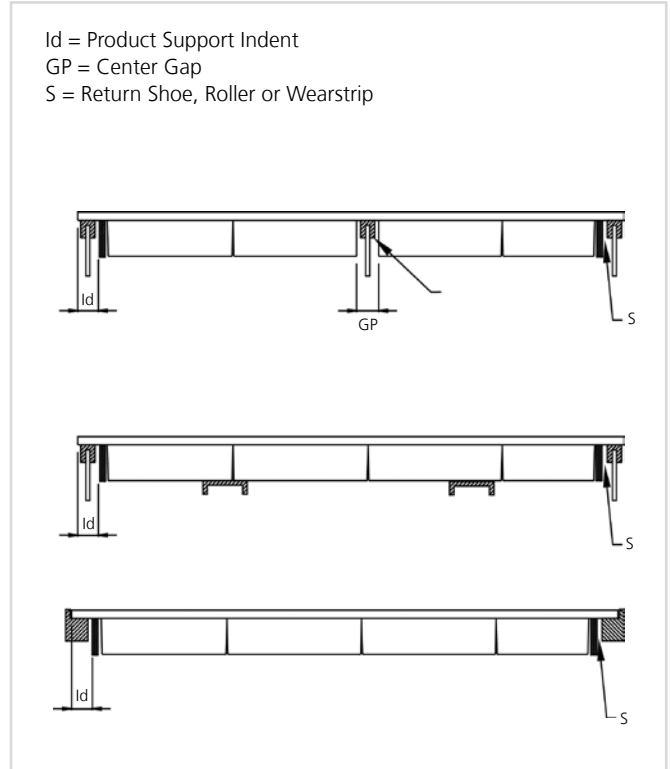

Figure 3-74

Anti-sag Carryway Wearstrip Configuration

Certain applications can result in allowing the belt to buckle ahead of the sprocket due to low tension in the belt. This can cause several concerns with the belt jamming in the conveyor or small conveyed products tipping. See figure 3-75.

Buckling can be overcome by extending the wearstrips between the sprockets see figure 3-76.

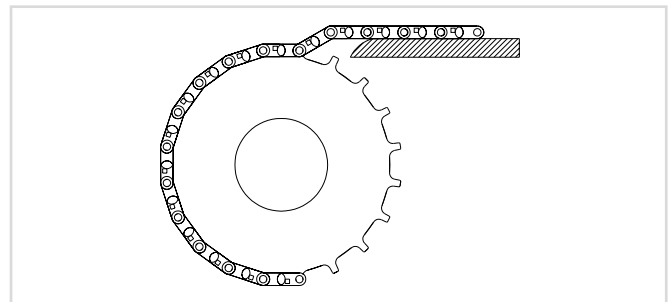

Figure 3-75

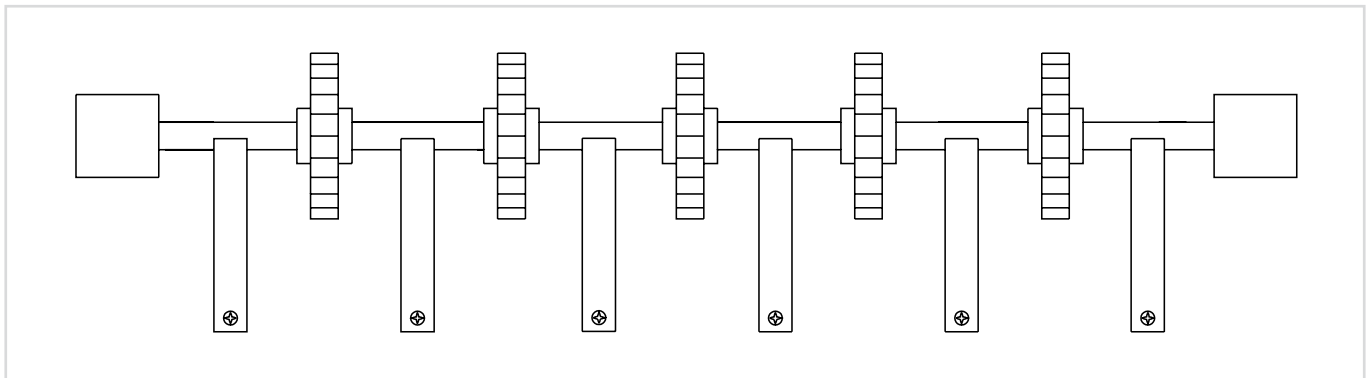

Figure 3-76

Take-up Methods

Control of Belt Length

Belt or Chain Running in One Direction

As temperature, load and friction vary, the belt expands or contracts, increasing or decreasing belt length respectively. To counteract this effect a catenary sag is used after the drive sprocket in the returnway. A catenary sag is a section of free hanging belt that absorbs excess belt in expansion or gives excess belt to the conveyor in the event of contraction. The catenary sag also serves as a weight on the return-way of the belt. This weight of the belt in the catenary sag is enough to ensure sprocket engagement by creating tension after the drive sprocket and before the idler sprocket.

When designing the conveyor frame, the designer must keep in mind the dimensions of the catenary sag and make sure that there are no obstructions hindering or supporting the catenary sag. If the sag rests on the conveyor frame, the effect of the sag to serve as a weight is reduced greatly. If the belt becomes too long, links

from the belt should be removed so the catenary sag is returned to its intended dimensions. Below are different setups for a conveyor with a catenary sag.

Keep in mind that for all return arrangements the backflex radius of the particular belt/chain must not be reduced. The backflex (or backbend) radius is the minimum negative bend (opposite of the belt bending over the sprocket) the belt can safely undergo. This value is different for each belt type and can also change for each belt/chain when certain accessories like sideguards are used. Backflex radius can be found for each belt in the uni-chains belt catalog on the product main page next to this icon:



Take-up Methods

Control of Belt Length

The following are standard return ways and a description of how they can control belt length depending on the situation of the conveyor. See figure 3-77, figure 3-78 and figure 3-79.

For standard applications a catenary sag is placed next to the drive sprockets as shown in the drawing. For applications at higher temperatures, the expansion in the chain/belt should be calculated first to determine if sufficient space is available.

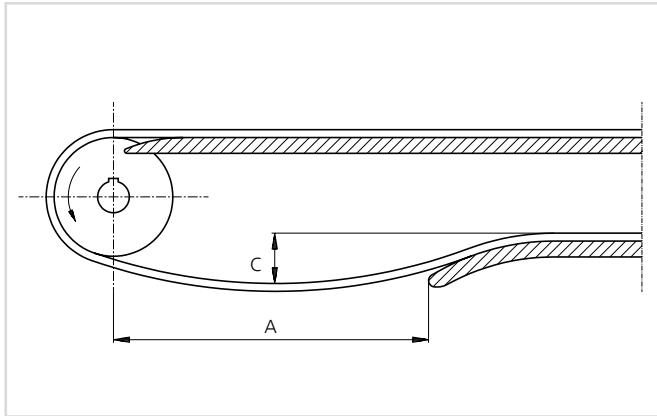

Figure 3-77

| | mm | in. |
|---|----------|-------|
| A | 500-2000 | 20-79 |
| C | 25-200 | 1-8 |

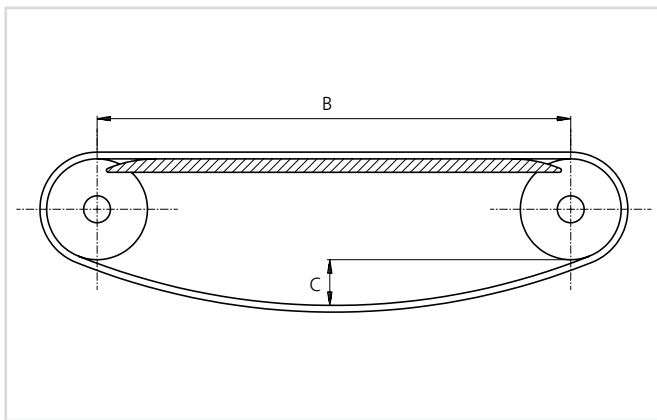

Figure 3-78

| | mm | in. |
|---|-----------|---------|
| B | max. 2000 | max. 79 |
| C | 25-200 | 1-8 |

Support on the return side can be omitted on short conveyors under two m (6.6 ft) so the belt hangs freely between the idler and drive sprocket.

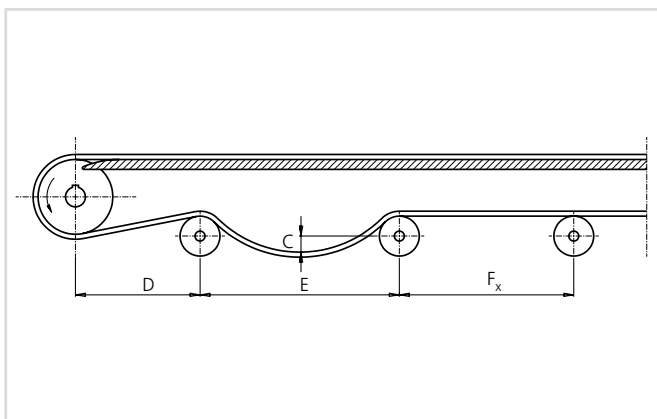

Figure 3-79

| | mm | in. |
|------------------|----------|-------|
| C | 25-100 | 1-8 |
| D | 0-2000 | 0-79 |
| E* | 500-2000 | 20-79 |
| F _x * | ≠ E | ≠ E |

*If $F_x < E$ catenary sag in section E
 If $F_x > E$ catenary section F_x
 Max. length of catenary sag is 2000 mm (79 in.)

For long conveyors a catenary sag will be placed where the biggest distance between two return rollers is to be found.
 Never make the same distance between return rollers.

Take-up Methods

Control of Belt Length

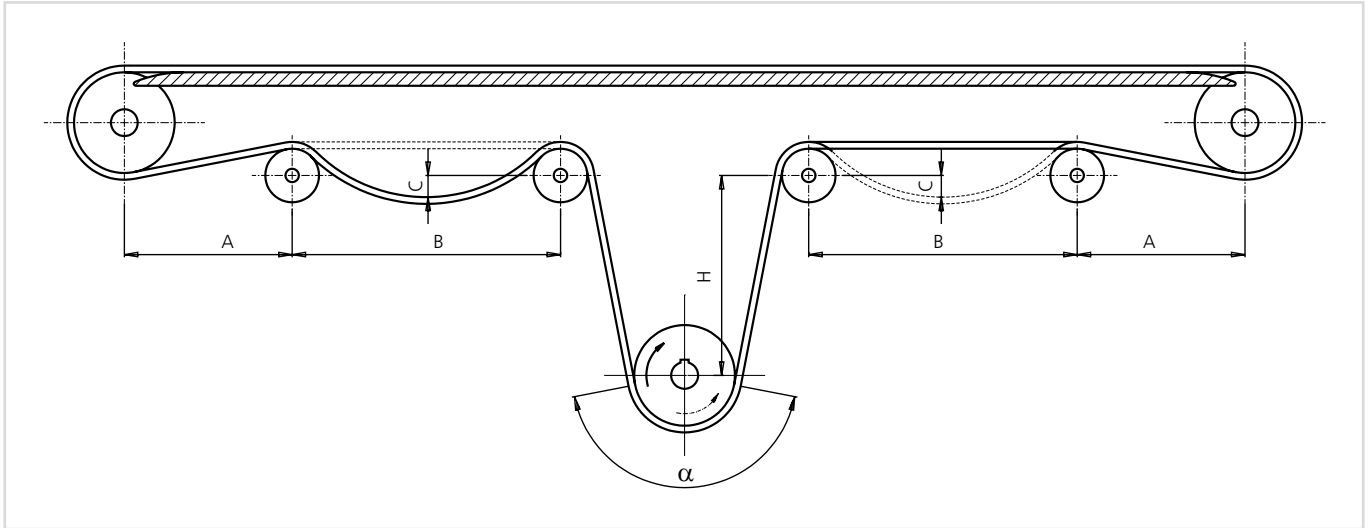

Figure 3-80

| | mm | in. |
|----------|------------|------------|
| A | 0-2000 | 0-79 |
| B | 500-2000 | 20-79 |
| C | 25-200 | 1-8 |
| H | min. 3 x P | min. 3 x P |
| α | 120°- 175° | 120°- 175° |

P = belt pitch

Belt or chain running in both directions
This pull/pull system requires only one gear/motor.
See figure 3-80.

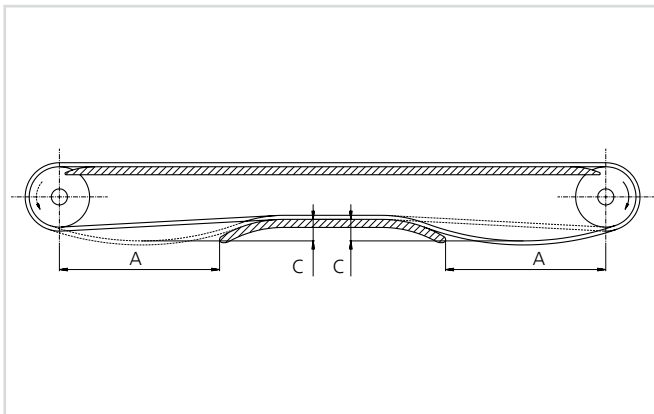

Figure 3-81

| | mm | in. |
|---|--------|------|
| A | 0-2000 | 0-79 |
| C | 25-200 | 1-8 |

This conveyor requires two motors (one at each end).
This construction requires the possibility of disconnecting
the motors. See figure 3-81.

Take-up Methods

Back Tension

It was presented in the previous section that a catenary sag also serves as a weight to create tension. This tension is called back tension. It is best to place the catenary sag directly after the drive sprocket, or if needed a “snub” roller may be placed after the drive sprocket and then the catenary sag thereafter. A “snub” roller should be placed at a height in relation to the drive shaft so that 180-210 degrees of wrap is created around the drive sprocket.

Back tension is easily adjustable by the size of the catenary sag. As the catenary sag dimensions increase, back tension increases. As the catenary sag dimensions decrease, back tension decreases. When increasing the catenary sag dimensions, always keep in mind the surroundings, such as the conveyor frame or drive components.

Special Take-up Arrangements

In cases where a catenary sag cannot provide adequate tension to ensure sprocket engagement, such as a very long and/or fast conveyor, alternate take-up methods must be implemented.

Gravity Style Take-ups

A gravity style take-up is a special type of take-up. It consists of a weighted roller or tensioning device that adds tension in the belt on the return side. It takes the place of a catenary sag and falls between the drive shaft and a supporting roller. See figure 3-82. Examples where a gravity style take up may be suitable include:

Conveyors:

- over 23 m (75 ft) long
- over 15 m long (50 ft long with belt speeds over 20 m/min.) (150 ft/min.)
- exposed to large temperature ranges
- operating at speeds over 15 m/min. (50 ft/min.), and with frequent starts under loads of over 120 kg/m² 25 lb/ft²

As a rule of thumb the following guidelines for weighted rollers can be used: 1 in. pitch belts and below, use a minimum 100 mm (4 in.) diameter roller with a weight of 15 kg/m (10 lbs/ft).

For 2 in. pitch belts and above, use minimum 150 mm (6 in.) diameter roller with a weight of 30 kg/m (20 lbs/ft). Keep in mind that this type of take-up increases wear between the pins and holes as tension is increased.

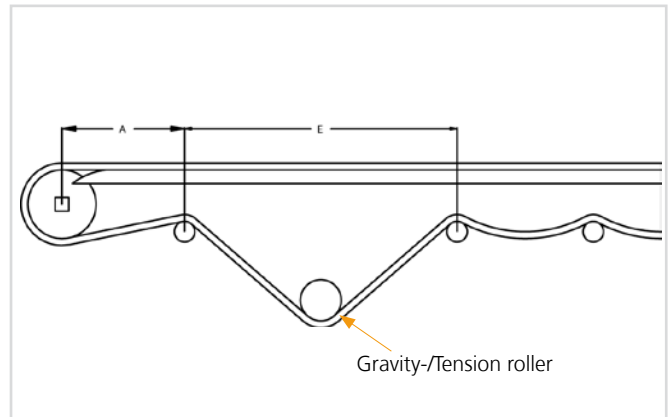

Figure 3-82

Screw, Spring or Cylinder Style Take-ups

To adjust the catenary sag back to its intended dimensions, a take-up can be installed on the idler shaft. The bearings for the idler shaft rest in horizontal slots so that the shaft can move as the screw, spring, or cylinder is adjusted. Potential issues with this system include:

- shafts can be misaligned
- belt can be over tightened causing greater wear and greater shaft deflection
- can increase total conveyor length

| | mm | in. |
|---|----------|-------|
| A | 100-500 | 4-20 |
| E | 500-1500 | 20-59 |

Take-up Methods

Special Take-up Arrangements

With these disadvantages, this kind of take-up should be a last option. Instead the belt should be worn in and modules should be removed by row(s) until the belt is back to its proper length. Figure 3-83 is a cross section of a typical screw style take-up.

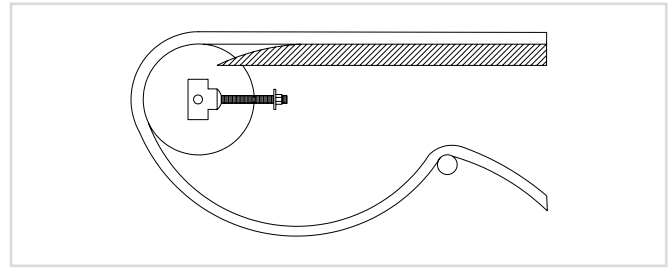

Figure 3-83

Screw, Spring or Cylinder Style take-ups

As a new belt is used, its pins settle into their links. This "breaks in" the belt and lengthens it. This extra length is then absorbed by the catenary sag and therefore increasing the dimensions of the catenary sag.

Compressed Belt Take-up

As an alternative to the classic catenary sag belt length take-up system, it is possible to compress certain belts in the longitudinal direction to absorb the belt stretch

that way. This can only be done with sideflexing belts or other belts that have the ability to compress in the longitudinal direction.

Driving Terminals

The uni-chains product range includes the development of the driving terminals as one way to utilize a compressed belt take-up. This consists of a pair of side plates mounted at the conveyor drive end to ensure correct belt/sprocket engagement.

A driving terminal system consists of side plates mounted at the driving and/or idle ends to ensure good engagement between belt and sprockets. These side plates have a slot machined into them to guide the belt and are mounted on either side to completely contain the belt. They keep the belt in place as it goes around the spro-

kets and prevent the belt from jumping. The use of driving terminals eliminates the need for catenary sag. The belt that is used must be flexible so that it can be compressed on the return thereby taking up any expansion of the belt. Furthermore, driving terminals ensure that the minimum engagement angle between the belt and the driving sprockets is 180°. The result is that a larger force can be transferred at the driving end than if you did not use a driving terminal. Figure 3-84 is a cross section of a typical side plate used in a driving terminal system.

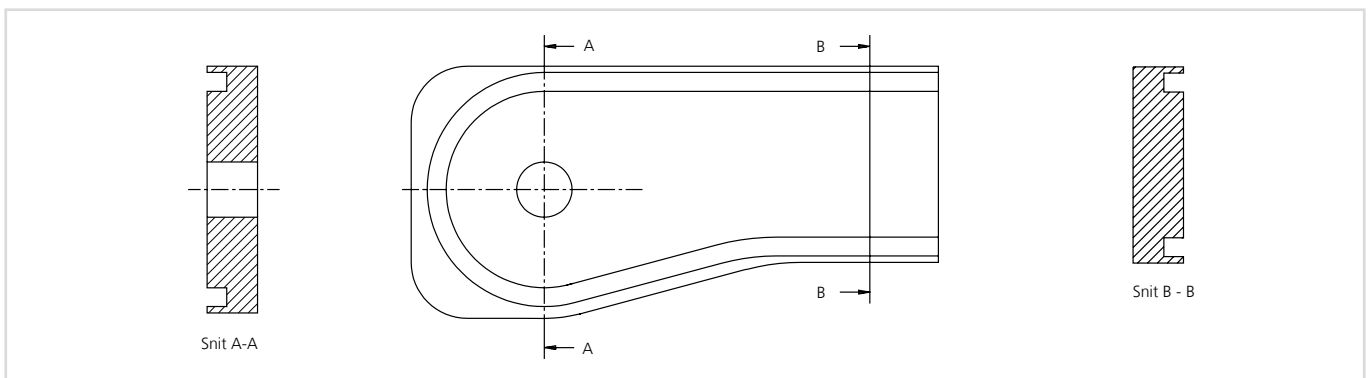

Figure 3-84

Advantages

- Space for catenary sag is not required. Very useful in applications with low headroom.
- Correct engagement between belt and sprockets is ensured under all operating conditions.
- Belt sprocket wrap of more than 180 degrees.
- Belt has positive release from sprocket.

Chain and Belt Material Listing and Properties

Plastic Materials, Temperature Range, Load Index and FDA

| Material Grades | Temperature Range | | Load/Permissible Load Index | FDA |
|---|-------------------|-------------|-----------------------------|-----|
| | °C | °F | | |
| POM - Polyoxymethylen ^{4/} | -40 to +90 | -40 to +194 | 100% POM | ✓ |
| POM-DK - Polyoxymethylen | -40 to +90 | -40 to +194 | 100% POM | - |
| POM-AS/NLAS - Semi Conductive Materials | -40 to +90 | -40 to +194 | 100% POM | - |
| POM-EC - Electrical Conductive Materials | -40 to +90 | -40 to +194 | 50% POM | - |
| PP - Polypropylene ^{2/ 3/} | +1 to +104 | +34 to +219 | 100% PP | ✓ |
| PP-I - Polypropylene | -10 to +80 | +14 to +176 | 80% PP | ✓ |
| PPMI - Metal Detectable Polypropylene | -10 to +80 | +14 to +176 | 70% PP | ✓ |
| PPHW - Hot Water Polypropylene | +1 to +104 | +34 to +219 | 100% PP | ✓ |
| PE - Polyethylene | -50 to +80 | -58 to +176 | 100% PE | ✓ |
| PEMI - Metal Detectable Polyethylene | -50 to +80 | -58 to +176 | 80% PE | ✓ |
| GR - Glass Reinforced Polyester ^{1/} | -40 to +125 | -40 to +257 | 70% POM | ✓ |
| PBT - Polyester ^{1/} | -40 to +100 | -40 to +212 | - | ✓ |
| AR - Glass Reinforced Polypropylene | +1 to +80 | +33 to +176 | 50% POM | - |
| FR - Flame Retardant Polyamide | +1 to +104 | +34 to +219 | 90% POM | - |
| PVDF - Polyvinylidenfluoride | -40 to +100 | -40 to +212 | 100% POM | ✓ |
| PA6 - Polyamide | -40 to +120 | -40 to +248 | 100% POM | ✓ |
| PA6-GF - Polyamide Glass Reinforced | -40 to +120 | -40 to +248 | 100% POM | - |
| PA6.6 - Polyamide | -40 to +140 | -40 to +284 | 100% POM | ✓ |
| PA6.6-H - Polyamide | -40 to +160 | -40 to +320 | 100% POM | - |
| PA6.6-GFH - Polyamide | -40 to +180 | -40 to +356 | 100% POM | ✓ |

^{1/} Maximum temperature in water +60°C (+140°F).

^{2/} Avoid impact below +8°C (+46°F).

^{3/} Dry. In and hot applications, use PPHW. Please, note that the temperature has an effect on the mechanical properties of the belts.

^{4/} POM-D/DI/ILF/SLF/NLIS/SX.

Chain and Belt Material Listing and Properties

Steel and Stainless Steel

| | Material Type | | |
|----------------------------|---|---|---|
| | Hardened Steel | Ferritic stainless Steel | Austenitic stainless Steel |
| | S800 S810 S881 S881 TAB S Magnet type S881 SFL | SS802 SS812 SS881 SS881 TAB SS Magnet type SS881 SFL SS8811 SFL SS8811 SS8811 TAB | SS805 SS815 SS881 SS881 TAB SS881 SFL SS 8811 SFL SS8811 SS8811 TAB |
| Short Definition | C45 | Werkstoff 1.4016 AISI 430 | Werkstoff 1.4301 AISI 304 |
| Detailed Definition | Hardened steel with a content of 0.45% carbon | A magnetic steel alloy where the main adds are 17.5% chrome | A non-magnetic steel alloy where the main adds are 18% chrome and 8% nickel |
| Advantages | High wearability Temperature range -70 to 430 °C (-94 to 806 °F) Hardened to 36 – 42 HRC High tensile strength | Good wearability Temperature range -70 to 430 °C (-94 to 806 °F) Good chemical resistance Better pricing compared to AISI 304 | Good wearability Temperature range -70 to 430 °C (-94 to 806 °F) High corrosion resistance High chemical resistance |
| Disadvantages | Poor corrosion resistance Poor chemical resistance | Reduced chemical resistance compared to AISI 304 Reduced corrosion resistance (can develop spots in wet environments when not in use for several weeks) | Pricing |
| Normally used | Where a high wear resistance is required Automotive industry - handling steel parts | Where the demand for high corrosion resistance is not the main issue In a competitive market where pricing is important Breweries Glass handling | Where demands for a high corrosion resistance is required Where (almost) non-magnetic materials are required Chemical productions Not used very often on conveyors in wet environments |

Chain and Belt Material Listing and Properties

Plastic Materials

| | Material Type | | |
|----------------------------|--|--|---|
| | POM- (D, LF, SLF) | POM-EC | Glass Reinforced PP (AR) |
| | Chains and Belts | Chains and Belts | Chains |
| Detailed definition | Polyoxymethylen | Polyoxymethylen electrically conductive | Polypropylene glass reinforced |
| Advantages | High tensile strength Good wearability Temperature range -40 to 90 °C (-40 to 194 °F) | Anti static properties Temperature range -40 to 90 °C (-40 to 194 °F) | Good chemical resistance Good wear resistance Temperature range 1 to 80 °C (33 to 176 °F) |
| Disadvantages | Pricing Relatively low chemical resistance | Pricing Limited physical properties | Limited physical properties |
| Normally used | Where there is a high wear In belts below 0 °C where PE not is strong enough In belts where PP is not strong enough Standard chain applications | Where a build up of static electricity must be avoided In aerosol fillers On conveyors directly served by humans | Where aggressive chemicals occur Where strong cleaning detergents occur |

Chain and Belt Material Listing and Properties

Plastic Materials

| | Material Type | | |
|----------------------------|--|--|---|
| | PBT (GR) | Polyamide (PA6, PA66) | Flame retardant polyamide (FR) |
| | Chains and Belts | Chains and Belts | Chains and Belts |
| Detailed definition | Polybutylenterephthalat glass reinforced | Polyamide 6 Polyamide 6.6 | Flame retardant Polyamide 6 |
| Advantages | High wear resistance Temperature range -40 to 125 °C (-40 to 257 °F) | Good wear resistance Wide temperature area Temperature range -40 to 150 °C (-40 to 302 °F) High tensile strength | Restricts fire according to UV labs V-0 (extinguish all types of fire) |
| Disadvantages | Limited physical properties Poor chemical properties Does not work in water at temperatures above 60 °C (140 °F) | Pricing Poor chemical properties Absorption of water (in total the volume increases by approx. 1%) | Pricing Poor chemical properties Absorption of water (in total the volume increases by approx. 1%) Lower impact resistance |
| Normally used | Where high wear occurs (automotive industry) | In applications where the temperature is above the range of POM In applications where POM cannot stand the wear | In applications where there is a risk of burning |

Chain and Belt Material Listing and Properties

Plastic Materials

| | Material Type | | |
|----------------------------|--|--|---|
| | Polycarbonate (PC) | Polyvinylidenfluoride (PVDF) | Xenoy (Xenoy) |
| | Chains (Snap-On chains only) | Chains and Belts | Belts |
| Detailed definition | Polycarbonate | Polyvinylidenfluoride | Xenoy |
| Advantages | Very high impact strength Temperature range -20 to 135 °C (-4 to 275 °F) | Good wear resistance Temperature range -40 to 100 °C (-40 to 212 °F) High chemical resistance | High impact resistance Temperature range -70 to 80 °C (-94 to 176 °F) |
| Disadvantages | Poor creep properties Impact properties disappear below 29 °C (84 °F) | Pricing | Low tensile strength Low wear resistance |
| Normally used | Where high impact occurs | Where aggressive chemicals occur | In applications where the temperature is low In applications with high impacts |

Chain and Belt Material Listing and Properties

Plastic Materials

| | Material Type | | |
|----------------------------|---|--|---|
| | Polyethylene (PE) | Polypropylene (PP) | - |
| Normally | Belts | Belts | - |
| Detailed definition | Polyethylene High density | Polypropylene | - |
| Advantages | <p>Low price</p> <p>Good chemical resistance</p> <p>Temperature range -50 to 80 °C (-58 to 176 °F)</p> <p>High impact strength</p> <p>Suitable for application with dry ice</p> | <p>Low price</p> <p>Good chemical resistance</p> <p>Temperature range 1 to 104 °C (34 to 219 °F)</p> | - |
| Disadvantages | <p>Poor tensile strength</p> <p>Poor creep properties</p> | <p>Becomes brittle at temperatures below 1 °C (34 °F)</p> <p>Poor impact strength</p> <p>Poor tensile strength</p> | - |
| Normally used | <p>Where a low price material is needed for use below 0°C (32 °F)</p> <p>Freezers</p> | <p>Where tensile strength and temperature enable it to be used or for chemical resistance</p> | - |

Factors

Values provided in the tables below are dynamic friction under clean conditions. Values will be 0.1 to 0.2 higher

at the starting moment. If possible it is recommended to start the conveyor unloaded and gradually apply load.

Friction Factors

| Material | UHMWPE Dry | UHMWPE Wet | UHMWPE with Oil | Nylatron NSM Dry | SS-steel Dry | SS-steel Wet |
|----------|------------|------------|-----------------|------------------|--------------|--------------|
| POM-NL | 0.20 | 0.15 | 0.12 | 0.22 | 0.25 | 0.21 |
| POM-D | 0.19 | 0.14 | 0.12 | 0.21 | 0.24 | 0.20 |
| POM-LF | 0.18 | 0.13 | 0.12 | 0.20 | 0.23 | 0.19 |
| POM-SLF | 0.17 | 0.12 | 0.12 | 0.19 | 0.22 | 0.18 |
| POM-SX | 0.15 | 0.10 | 0.11 | 0.17 | 0.20 | 0.16 |
| PP | 0.25 | 0.20 | 0.15 | 0.28 | 0.30 | 0.27 |
| PE | 0.25 | 0.20 | 0.15 | 0.28 | 0.25 | 0.20 |
| PA6 | 0.20 | N/a | 0.15 | 0.22 | 0.30 | n/a |
| GR | 0.26 | 0.22 | 0.18 | 0.29 | 0.32 | 0.25 |
| AR | 0.26 | 0.22 | 0.18 | 0.29 | 0.32 | 0.25 |

Temperature Factors

| | POM | PP | PE | PA6.6 | PA6.6-GFH |
|-----------|------|------|------|-------|-----------|
| at -79 °C | n/a | n/a | 1.35 | n/a | n/a |
| at -40 °C | 1.05 | n/a | 1.30 | 1.10 | 1.00 |
| 1 °C | 1.05 | 1.00 | 1.10 | 1.05 | 1.00 |
| 20 °C | 1.00 | 1.00 | 1.00 | 1.00 | 1.00 |
| 40 °C | 0.95 | 0.85 | 0.50 | 0.90 | 1.00 |
| 60 °C | 0.90 | 0.60 | 0.40 | 0.55 | |
| 80 °C | 0.60 | 0.40 | 0.25 | 0.30 | |
| 90 °C | 0.40 | 0.35 | n/a | 0.25 | |
| 100 °C | n/a | 0.25 | n/a | 0.20 | |
| 120 °C | n/a | n/a | n/a | 0.17 | |
| 140 °C | n/a | n/a | n/a | 0.16 | |
| 126 °C | n/a | n/a | n/a | n/a | |
| 180 °C | n/a | n/a | n/a | n/a | |

In general

The plastic chains are not resistant to liquids with a pH-value lower than 4.5 or higher than 9.0. Cleaning with strong detergents should be avoided.

Smooth running is obtained by correct service, cleaning, lubrication and regular control.

Warning

If plastic chains and plastic wearstrips are used at temperatures higher than recommended or when welding there is a danger of ignition of the plastic material.

Note

- Flames from plastic material may be invisible.
- Ignited plastic material may generate poisonous smoke.

Chain Calculations

Tensile Forces

Variable Key

| | |
|----------------|---|
| α° | = Center angle for curve segment (degrees) |
| S_x | = Length of arch, m (ft) |
| F | = Tensile force, N (lbf) |
| m_p | = Product weight, kg/m (lbs/ft) |
| m_c | = Chain weight, kg/m (lbs/ft). See table on chain weights in the uni-chains chain catalog |
| L_x | = Horizontal length of conveyor section, m (ft) |
| K_{cw} | = Curve factor, chain-wearstrip. See table in appendix on page 99 |
| K_{cp} | = Curve factor, chain-product. See table in appendix on page 99 |
| R_x | = Center radius of conveyor section |
| μ_1 | = Friction coefficient, chain-wearstrip. See table in appendix on page 97 |
| μ_2 | = Friction coefficient, chain-product. See table in appendix on page 97 |
| C | = Force conversion factor. Metric: 9.8; Imperial: 1.0 |
| $F_{adj.}$ | = Maximum adjusted permissible tensile force, N (lbf) |
| SF | = Service factor. See table in appendix on page 98 |

Equations

Straight chain without accumulation

$$F = (m_p + 2 \times m_c) \times L_1 \times \mu_1 \times C \times SF$$

Straight chain with accumulation

$$F = [(m_p + 2 \times m_c) \times L_1 \times \mu_1 + m_p \times \mu_2 \times L_1] \times C \times SF$$

Sideflexing chain without accumulation

$$F = (m_p + 2 \times m_c) \times S \times \mu_1 \times C \times K_{cw} \times SF$$

Sideflexing chain with accumulation

$$F = [(m_p + 2 \times m_c) \times S \times \mu_1] \times K_{cw} + m_p \times S \times \mu_2 \times K_{cp}] \times C \times SF$$

Load control

The calculated tensile force in the chain should be lower than the adjusted permissible tensile force for that given chain. Such that $F \leq F_{adj.}$

Be sure to apply temperature and speed factors to $F_{adj.}$ before checking against the calculated force.

Temperature and Speed dependent Tensile Force

The permissible tensile force depends on the temperature. Thus the permissible tensile force is reduced at working temperatures higher than 20 °C (68 °F). At working temperatures below +20 °C (+68 °F), a higher tensile force is permissible. However, note that at low temperature as the tensile force increases, the toughness will deteriorate, so that the material

becomes more brittle. Speed also has an influence on permissible tension and we account for this with a speed factor. Plastic is limited by a combination of load and speed so as speed increases, permissible load must go down, and vice versa. Speed also has an influence on conditions like wear, fatigue and noise.

Variable Key

| | |
|-------------|---|
| $F_{perm.}$ | = Maximum permissible force, N (lbf). See table in uni-chains belt catalog. |
| T | = Working temperature, °C (°F) |
| C_T | = Temperature factor. See table in appendix on page 98 |
| C_S | = Speed factor. See table in appendix on page 98 |
| $F_{adj.}$ | = Maximum adjusted permissible tensile force, N (lbf) |

Equation

$$F_{adj.} = C_T \times C_S \times F_{perm.}$$

Chain Calculations

Conveyor with straight running and sideflexing Chains

The following shows examples of conveyors with both straight running and sideflexing chains. See figure 5-1.

An overall tensile force at the drive end is to be calculated as:

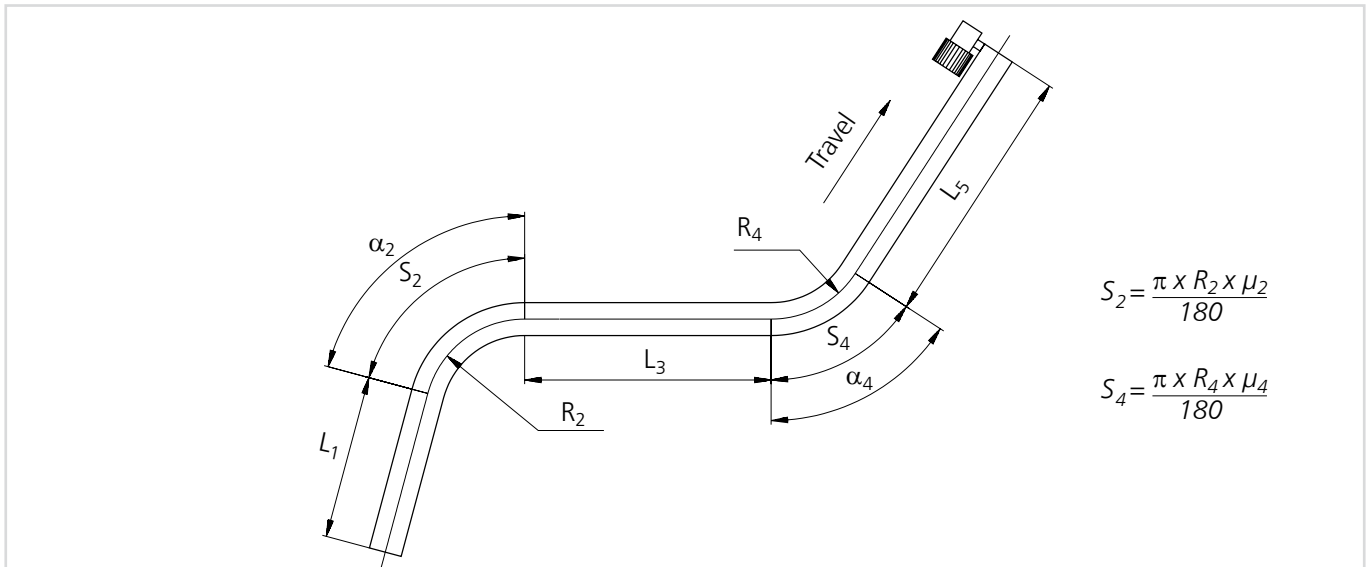

Figure 5-1

Traction without Accumulation

Section 1 at 1

$$F_1 = (m_p + 2 \times m_c) \times L_1 \times \mu_1 \times C$$

Sections 1 and 2 at 2

$$F_2 = [F_1 + (m_p + 2 \times m_c) \times S_2 \times \mu_1 \times C] \times K_{cw}$$

Sections 1, 2 and 3 at 3

$$F_3 = F_2 + (m_p + 2 \times m_c) \times L_3 \times \mu_1 \times C$$

Sections 1, 2, 3 and 4 at 4

$$F_4 = [F_3 + (m_p + 2 \times m_c) \times S_4 \times \mu_1 \times C] \times K_{cw}$$

Sections 1, 2, 3, 4 and 5 at 5

$$F_5 = [F_4 + (m_p + 2 \times m_c) \times L_5 \times \mu_1 \times C] \times SF$$

Load Control

$$F_5 \leq F_{adj.}$$

Traction with Accumulation

Section 1 at 1

$$F_1 = [(m_p + 2 \times m_c) \times L_1 \times \mu_1 + m_p \times \mu_2 \times L_1] \times C$$

Section 1 and 2 at 2

$$F_2 = [F_1 + (m_p + 2 \times m_c) \times S_2 \times \mu_1 \times C] \times K_{cw} + m_p \times S_2 \times \mu_2 \times C$$

Sections 1, 2 and 3 at 3

$$F_3 = F_2 + (m_p + 2 \times m_c) \times L_3 \times \mu_1 \times C + m_p \times L_3 \times \mu_2 \times C$$

Sections 1, 2, 3 and 4 at 4

$$F_4 = [F_3 + (m_p + 2 \times m_c) \times S_4 \times \mu_1 \times C] \times K_{cw} + m_p \times S_4 \times \mu_2 \times K_{cp} \times C$$

Sections 1, 2, 3, 4 and 5 at 5

$$F_5 = [F_4 + (m_p + 2 \times m_c) \times L_5 \times \mu_1 \times C + m_p \times L_5 \times \mu_2 \times C] \times SF$$

Chain Calculations

Conveyor with Inclination

The following shows example of conveyor with inclination: See figure 5-2.

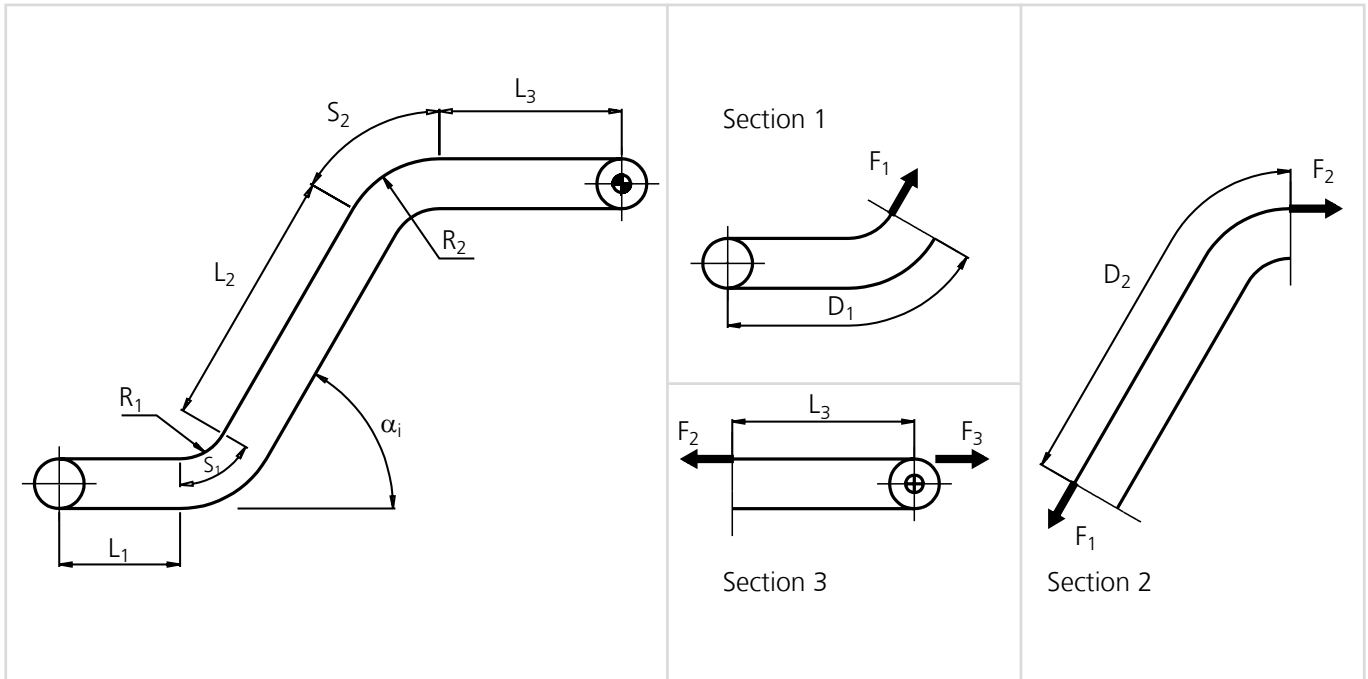

Figure 5-2

Variable Key

- α_i° = Inclination angle (degrees)
- F = Tensile force, N (lbf)
- L_x = Length of straight section, m (ft)
- S_x = Length of arch, m (ft)
- D_x = Length of section, m (ft)
- m_p = Product weight, kg/m (lbs/ft)
- m_c = Chain weight, kg/m (lbs/ft). See table on chain weights in uni-chains chain catalog
- μ_1 = Friction coefficient, chain-wearstrip. See table in appendix on page 97
- K_{inc} = Inclination factor. Same as curve factor. See table in appendix on page 99
- C = Force conversion factor. Metric: 9.8; Imperial: 1.0
- $F_{adj.}$ = Maximum adjusted permissible tensile force, N (lbf). See on page 63
- SF = Service factor. See table in appendix on page 98

Equations

$$F_1 = (2 \times m_c + m_p) \times \mu_1 \times D_1 \times C \times K_{inc}$$

$$D_1 = L_1 + S_1$$

$$S_1 = \frac{\pi \times R_1 \times \alpha_i}{180}$$

$$F_2 = [F_1 + m_p \times (\mu_1 \times \cos \alpha_i + \sin \alpha_i) \times C \times D_2] \times K_{inc}$$

$$D_2 = L_2 + S_2$$

$$S_2 = \frac{\pi \times R_2 \times \alpha_i}{180}$$

$$F_3 = [F_2 + (2 \times m_c + m_p) \times \mu_1 \times L_3 \times C] \times SF$$

Load Control

$$F_3 \leq F_{adj.}$$

Chains Calculations

Serpentine

Calculation of Center Distance between Turn Discs

To obtain the best serpentine construction we recommend a certain center distance between the turn discs. See figure 5-3.

L_{min} , it is necessary to know the height difference between two turn (h) discs as there must be a suitable clearance between the products and the turn disc section above (h_f).

To determine the center distance between the turndiscs,

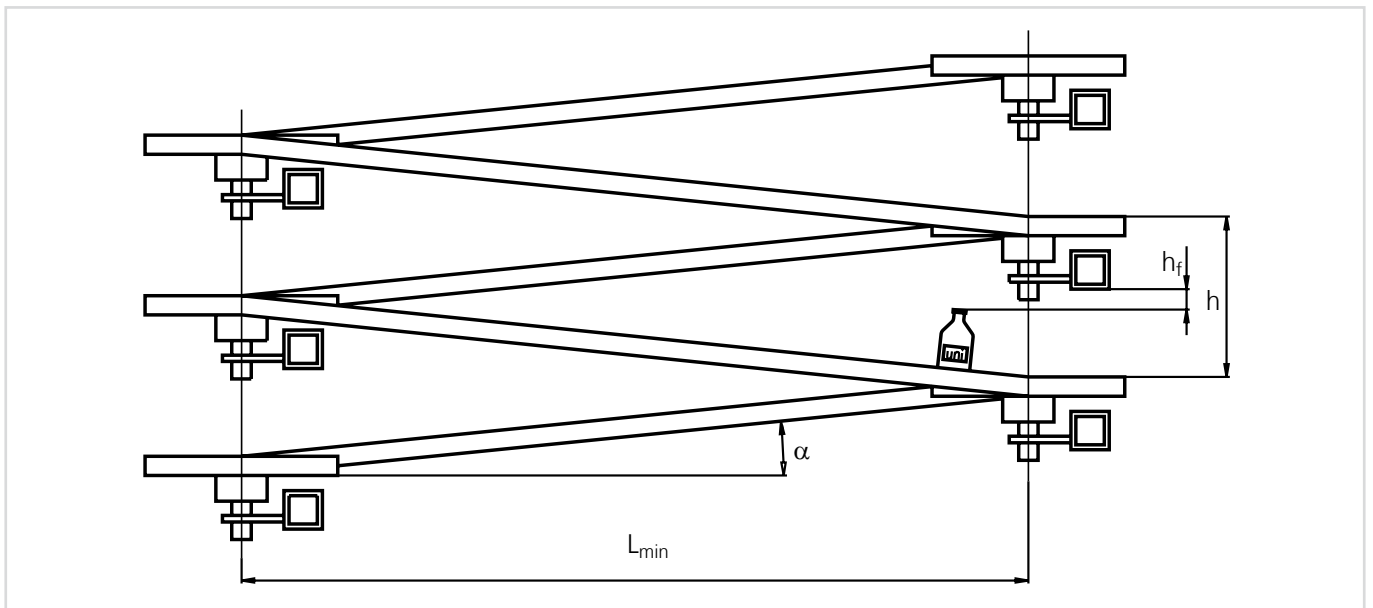

Figure 5-3

Variable Key

- L_{min} = Minimum center distance between the turn discs
- h = Height difference between the turn discs
- α = Inclination on the straight lengths
- h_f = Clearance between product and turn

Equation

$$L_{min} = \frac{h}{2 \times \tan \alpha}$$

Chain Calculations

Serpentine

Determination of Tensile Force in the Chain

Variable Key

| | |
|------------------|---|
| F_C | = Tensile force in the chain, N (lbf) |
| A | = Tensile force per straight length, N (lbf) |
| L | = Center distance between turn discs, m (ft) $L \geq L_{min.}$ |
| m_p | = Product weight, kg/m (lbs/ft) |
| m_c | = Chain weight, kg/m (lbs/ft). See table on chain weights in uni-chains chain catalog |
| μ_1 | = Friction coefficient, chain-wearstrip. See table in appendix on page 97 |
| μ_2 | = Friction coefficient, chain-product. See table in appendix on page 97 |
| α_i° | = Inclination angle for straight section |
| R | = Turn disc radius, m (ft) |
| C | = Force conversion factor. Metric: 9.8; Imperial: 1.0 |
| $F_{adj.}$ | = Maximum adjusted permissible tensile force, N (lbf). See table on page 63 |
| SF | = Service factor. See table in appendix on page 98 |

Equations

$$F_C = [\sum A] \times SF$$

$$A = \left[\frac{L}{\cos \alpha} [(m_c + m_p)(\sin \alpha_i + \mu_1 \times \cos \alpha_i) + m_p \times \mu_2 \times \cos \alpha_i] + \pi \times R \times [\mu_1 \times (m_p + m_c) + \mu_2 \times m_p] \right] \times C$$

Load Control

$$F_C \leq F_{adj.}$$

Belt Calculations

Tensile Forces

The tensile force in a straight running belt conveyor with horizontal transport can be calculated by using of below equation. See figure 5-4.

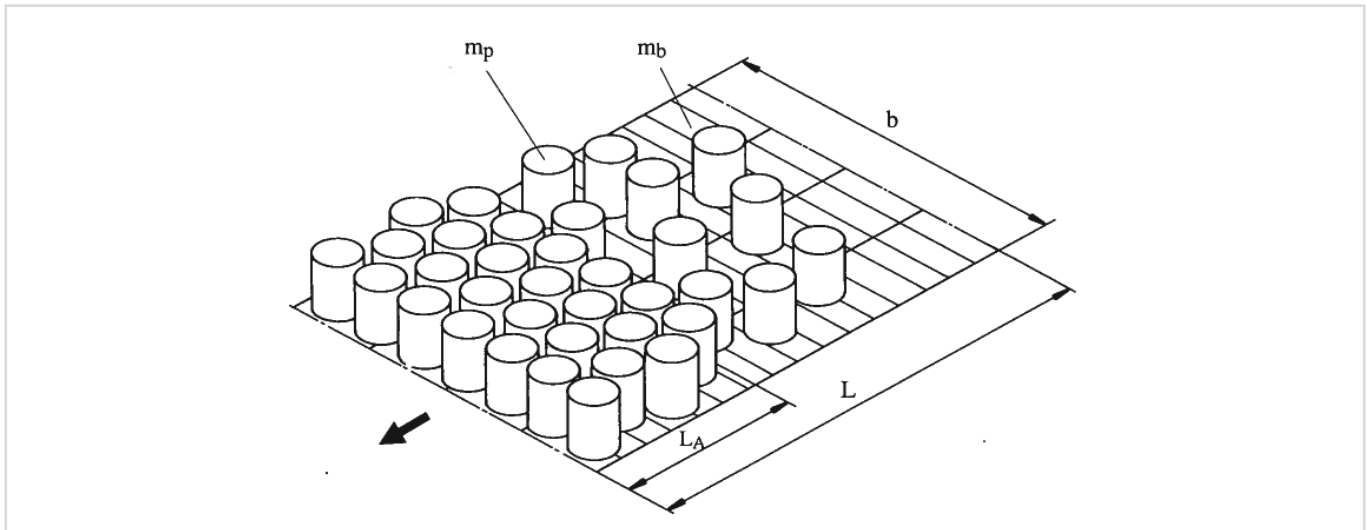

Figure 5-4

Variable Key

- F_B = Tensile force in the belt, N (lbf)
- m_p = Product weight, kg/m^2 (lb/ft^2)
- m_b = Belt weight, kg/m^2 (lb/ft^2). See table on belt weights in uni-chains belt catalog
- L = Conveyor length, m (ft)
- L_A = Length where accumulation occurs, m (ft)
- μ_1 = Friction coefficient, belt-wearstrip. See table in appendix on page 97
- μ_2 = Friction coefficient, belt-product. See table in appendix on page 97
- b = Belt width, m (ft)
- $F_{adj.}$ = Maximum adjusted permissible tensile force. See table in appendix on page 63
- C = Force conversion factor. Metric: 9.8; Imperial: 1.0
- SF = Service factor. See table in appendix on page 98

Equations

$$F_1 = [(m_p + 2 \times m_b) \times L \times \mu_1 + m_p \times L_A \times \mu_2] \times b \times C \times SF$$

Load Control

$$\frac{F_B}{b} < F_{adj.}$$

The possibilities of choosing a different belt material, using reinforcement links in the belt or changing in the parameters m_p , L , L_A , μ_1 or μ_2 should be considered if their load is too heavy.

Belt Calculations

Conveyor with Inclination

Calculation of necessary minimum speed, when product quantity per hour is known.
There are two different situations.

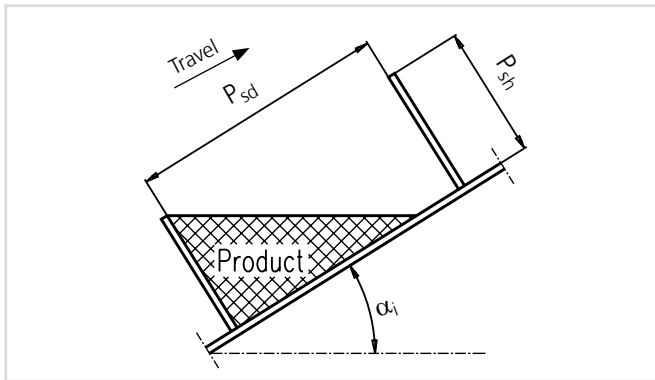

Figure 5-5

Situation 1

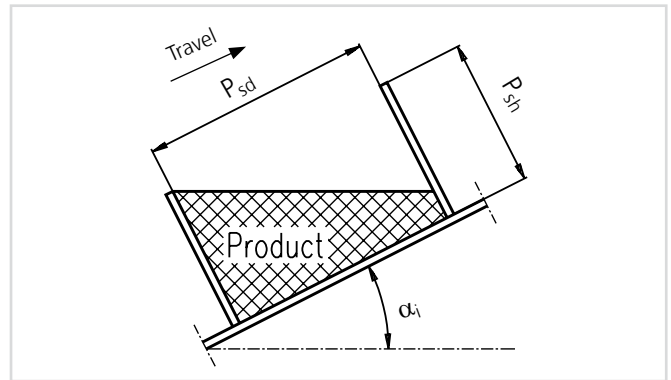

Figure 5-6

Situation 2

Variable Key

| | |
|----------|--|
| V_b | = Necessary minimum speed, m/min. (ft./min.) |
| P_{sw} | = Effective width of product support, m (ft.) |
| P_{sh} | = Height of product support, m (ft.) |
| P_{sd} | = Distance between product supports, m (ft.) |
| P_{wh} | = Transported product weight per hour, kg (lbs) |
| ρ_p | = Density of product, kg/m ³ (lbs/ft ³) |

1. The distance between the product supports will allow the product to lie as shown on figure 5-5.

2. The distance between the product supports will allow the product to lie as shown on figure 5-6.

By use of the following formula, you can determine the situation:

If $\text{InvTAN} \left(\frac{P_{sh}}{P_{sd}} \right) \leq \alpha_i$ - you have situation 1 on figure 5-5

If $\text{InvTAN} \left(\frac{P_{sh}}{P_{sd}} \right) > \alpha_i$ - you have situation 2 on figure 5-6

Necessary minimum speed according to situation 1

$$V_b = \frac{P_{wh} \times P_{sd} \times 2 \times \text{TAN}(\alpha_i)}{P_{sh}^2 \times P_{sw} \times \rho_p \times 60}$$

Necessary minimum speed according to situation 2

$$V_b = \frac{P_{wh}}{(P_{sh} - 0.5 \times P_{sd} \times \text{TAN}(\alpha_i)) \times P_{sw} \times \rho_p \times 60}$$

Belt Calculations

Conveyor with Inclination

The following shows an example of conveyor with inclination: See figure 5-7.

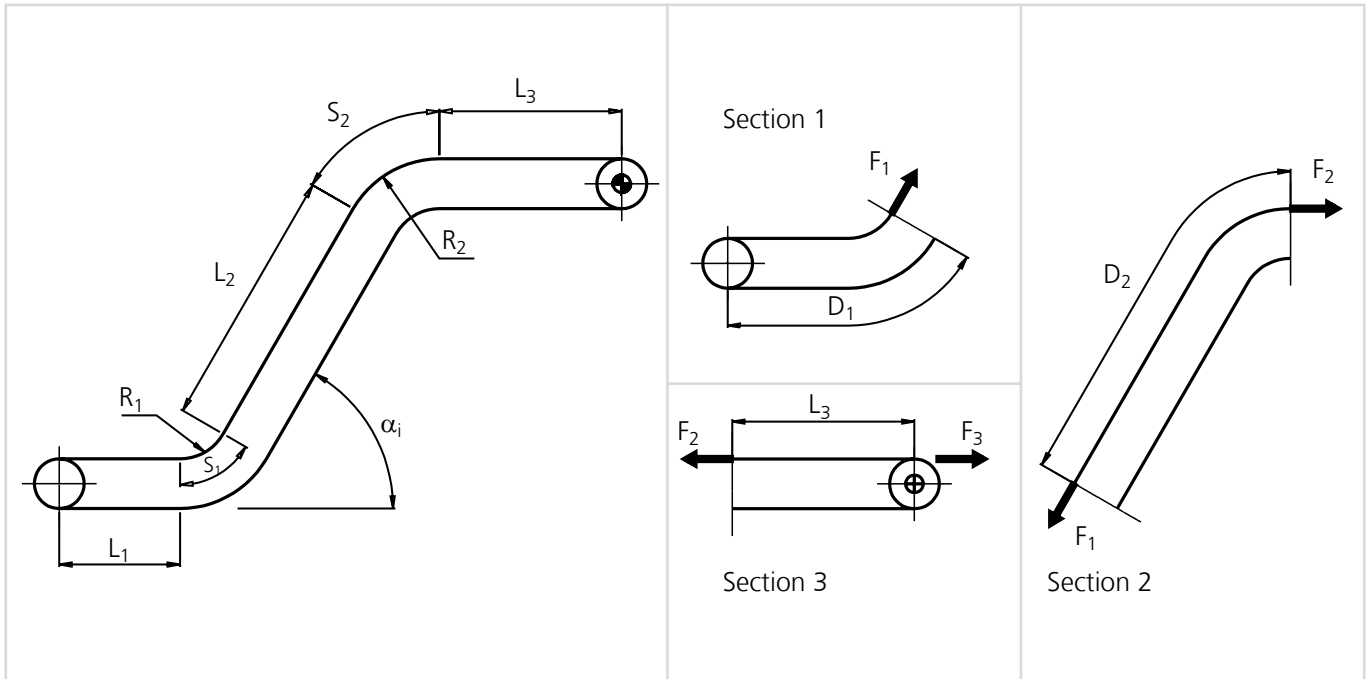

Figure 5-7

Variable Key

| | |
|------------------|--|
| α_i° | = Center angle for curve segment (degrees) |
| F | = Tensile force, N (lbf) |
| L | = Length of the conveyor section, m (ft) |
| m_p | = Product weight, kg/m ² (lb/ft ²) |
| m_b | = Belt weight, kg/m ² (lb/ft ²). See table on belt weights in uni-chains belt catalog |
| μ_1 | = Friction coefficient, belt-wearstrip. See table in appendix on page 97 |
| K_{inc} | = Inclination factor. Same as curve factor. See table in appendix on page 99 |
| b | = Belt width, m (ft) |
| C | = Force conversion factor. Metric: 9.8; Imperial: 1.0 |
| $F_{adj.}$ | = Maximum adjusted permissible tensile force, N (lbf). See table in appendix on page 63 |
| SF | = Service factor. See table in appendix on page 98 |

Equations

$$F_1 = (2 \times m_b + m_p) \times \mu_1 \times D_1 \times b \times C \times K_{inc}$$

$$D_1 = L_1 + S_1$$

$$S_1 = \frac{\pi \times R_1 \times \alpha_i}{180}$$

$$F_2 = [F_1 + m_p \times (\mu_1 \cos \alpha_i + \sin \alpha_i) \times C \times D_2 \times b] \times K_{inc}$$

$$D_2 = L_2 + S_2$$

$$S_2 = \frac{\pi \times R_2 \times \alpha_i}{180}$$

$$F_3 = [F_2 + (2 \times m_b + m_p) \times \mu_1 \times L_3 \times C] \times SF$$

Load Control

$$\frac{F_3}{b} \leq F_{adj.}$$

Belt Calculations

Reinforcement of Belt Systems

Variable Key

| | |
|-------------|--|
| $F_{B,b}$ | = Tensile force in the belt, N/m (lbf/ft) |
| $E_{perm.}$ | = Maximum permissible tensile force for the reinforcement links, N/pcs (lbf/pcs) |
| $n_{mod.}$ | = Number of reinforcement links per module, Ea |
| $n_{met.}$ | = Number of reinforcement links per meter, Ea |
| $n_{ft.}$ | = Number of reinforcement links per feet, Ea |

Permissible tensile force for the reinforcement links $E_{perm.}$ can be found in the uni-chains belt catalog.

**Note: uni Flex SNB can only accommodate two rows of reinforcement links on the outer edge of the turn radius.*

Required number of reinforcement links per meter/feet

Metric

$$n_{met.} \geq \frac{F_{B,b}}{E_{perm.}}$$

Imperial

$$n_{ft.} \geq \frac{F_{B,b}}{E_{perm.}}$$

Required number of reinforcement links per module

Metric

$$n_{mod} = \frac{n_{met.}}{6.56}$$

Imperial

$$n_{mod} = \frac{n_{ft.}}{2}$$

Belt Calculations

Expansion and Contraction of the Belt

Expansion/contraction of the belt may occur at special working conditions where the belt is exposed to changes in temperature.

Such changes in the belt width and belt length must be taken into consideration when the conveyor is constructed.

Variable Key

- ΔL = Length/width expansion, mm (in.)
- L = Length/width of belt at temperature T_1 , m (ft)
- T_2 = Working temperature, °C (°F)
- T_1 = Surrounding temperature, °C (°F)
- e_c = Expansion coefficient. See table below.

Expansion Coefficients (e_c)

| | $\frac{mm}{m \times ^\circ C}$ | $\frac{in.}{ft \times ^\circ F}$ |
|-----------|--------------------------------|----------------------------------|
| POM | 0.12 | 0.0008 |
| PP | 0.13 | 0.0009 |
| PE | 0.18 | 0.0012 |
| PA6/PA6.6 | 0.11 | 0.0007 |

The change in belt dimensions formula

$$\Delta L = L \times e_c \times (T_2 - T_1)$$

Expansion/contraction in the longitudinal direction can be minimized by use of steel reinforcement links.

Determining Number of Sprockets for Belt Systems

The number of sprockets required for the belt conveyor depends on the load on the belt and the temperature under which the conveyor is working. As a rule of thumb

uni-chains recommends a minimum of one sprocket per 6 in. module. Below is the equation to determine the minimum number of sprockets needed.

Variable Key

- n_{sp} = Minimum number of sprockets required for the belt, Ea
- b = Belt width, m (ft)
- $SP_{perm.}$ = Permissible load per sprocket, N/Ea (lbf/Ea). See uni-chains belt catalog.
- F_B = Tensile force in the belt, N(lbf).

Metric

$$n_{sp.} \approx \frac{b}{0.1524} + 1$$

Imperial

$$n_{sp.} \approx \frac{b}{0.5} + 1$$

Belt Calculations

Determining Number of Sprockets for Belt Systems

Permissible load per sprocket differs for each belt and material combination and can be found in the uni-chains belt catalog. Care must be taken that the selected belt can accommodate the number of sprockets required. Number of sprocket paths, placement of tabs and reinforcement links must be considered when determining the possible number of sprockets.

After having calculated the quantity of sprockets, it is necessary to make a control in order to see, if there are enough sprockets considering the load.

By use of the following formula, you can control this:

$$n_{sp} \geq \frac{F_B}{SP_{perm.}}$$

General Calculations

Catenary Sag

A freely hanging conveyor belt will form a belt arch between two supports. Knowing the amount of belt absorbed in the belt arch and the load from the belt arch is important. See figure 5-8.

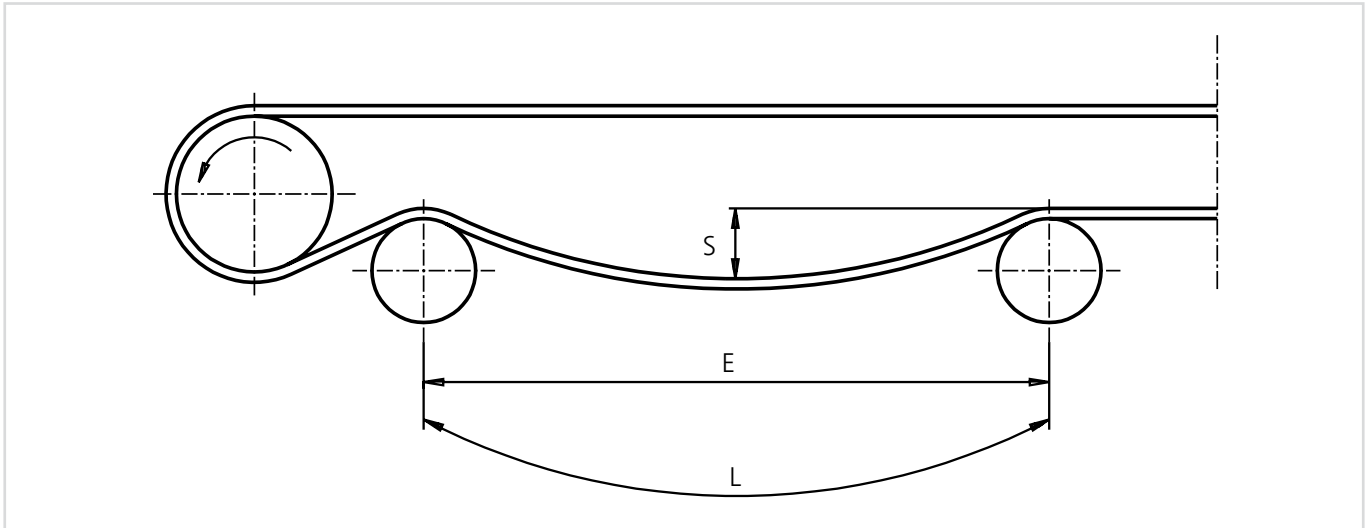

Figure 5-8

Variable Key

- L = Length of belt arch, m (ft)
- F = Tension from the belt arch, N (lbf) of belt width
- E = Distance between supports, m (ft)
- b = Belt width, m (ft)
- m_b = Belt weight, kg/m^2 (lb/ft^2). See table on belt weights in uni-chains belt catalog
- S = Catenary sag, m (ft)
- C = Force conversion factor. Metric: 9.8; Imperial: 1.0

Length of Belt Arch

$$L \approx \frac{2.66 \times S^2}{E} + E$$

Load from the Belt Arch

$$\frac{E^2 \times m_b \times b \times C}{8 \times S}$$

General Calculations

Dimensioning of the Motor

Variable Key

| | |
|----------|--|
| P | = The required power, kW (HP) |
| F | = Tensile force in belt or chain, N (lbf) |
| v | = Belt or chain speed, m/min. (ft/min.) |
| η | = Efficiency of gear |
| T | = Torque on drive shaft, Nm (lbfft) |
| GR | = Gear ratio |
| R_{dm} | = Number of revolutions on drive motor, RPM |
| R_{ds} | = Number of revolutions on drive shaft, RPM |
| P_d | = Pitch diameter of drive sprocket, mm (in.) |

Required Power

Metric

$$P = \frac{F \times v}{60000 \times \eta}$$

Imperial

$$P = \frac{F \times v}{33000 \times \eta}$$

Note: In this formula allowance for losses is not made in other mechanical parts than the gear. When calculating conveyors with inclination, allowance must be made for the energy required for lifting the product and then chain or belt.

Torque on Drive Shaft

Metric

$$T = \frac{F \times P_d}{2000}$$

Imperial

$$T = \frac{F \times P_d}{24}$$

Number of Revolutions on Drive Shaft, RPM

Metric

$$R_{ds} = \frac{v \times 1000}{P_d \times \pi}$$

Imperial

$$R_{ds} = \frac{v \times 12}{P_d \times \pi}$$

Number of Revolutions on Drive Motor

$$R_{dm} = R_{ds} \times GR$$

General Calculations

Dimensioning of the Shaft (Steel)

Round Shaft

Variable Key

- d = Minimum diameter of drive shaft, mm (in.)
 p_d = Pitch diameter of drive sprocket, mm (in.)
 F = Tensile force in the chain or belt, N (lbf)

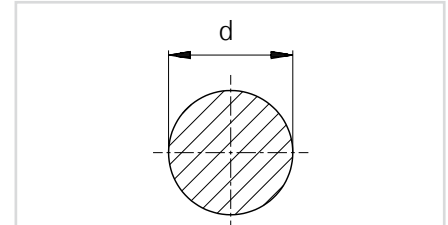

Figure 5-9

Minimum Diameter of round Drive Shaft

Metric

$$d \geq 0.51 \times \sqrt[3]{p_d \times F}$$

Imperial

$$d \geq 0.1 \times \sqrt[3]{p_d \times F}$$

Hollowed round Shaft

Variable Key

- d = Minimum diameter of drive shaft, mm (in.)
 d_i = Inside diameter of drive shaft, mm (in.)
 d_0 = Pitch diameter of drive sprocket, mm (in.)
 F = Tensile force in the chain or belt, N (lbf)

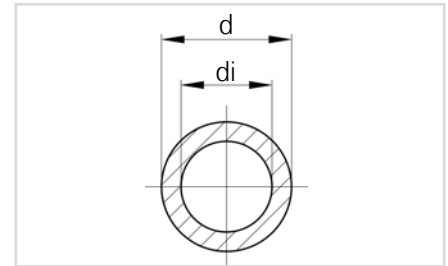

Figure 5-10

Minimum Diameter of hollowed Drive Shaft

Metric

$$d \geq 0.51 \times \frac{\sqrt[3]{p_d \times F}}{\sqrt[3]{1 - \left(\frac{d_i}{d}\right)^4}}$$

Imperial

$$d \geq 0.1 \times \frac{\sqrt[3]{p_d \times F}}{\sqrt[3]{1 - \left(\frac{d_i}{d}\right)^4}}$$

Square Shaft

Variable Key

- b = Minimum outside dimension of square drive shaft, mm (in.)
 d_0 = Pitch diameter of drive sprocket, mm (in.)
 F = Tensile force in the chain or belt, N (lbf)

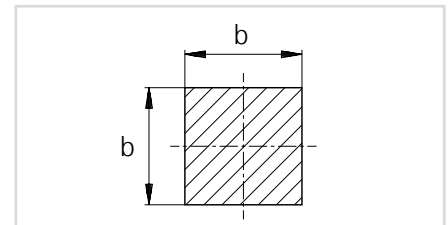

Figure 5-11

Minimum Diameter of Square Drive Shaft

Metric

$$b \geq 0.48 \times \sqrt[3]{p_d \times F}$$

Imperial

$$b \geq 0.09 \times \sqrt[3]{p_d \times F}$$

Hollowed Square Shaft

Variable Key

- b = Minimum outside dimension of hollowed square drive shaft, mm (in.)
- a = Inside dimension of hollowed square drive shaft, mm (in.)
- p_d = Pitch diameter of drive sprocket, mm (in.)
- F = Tensile force in the chain or belt, N (lbf)

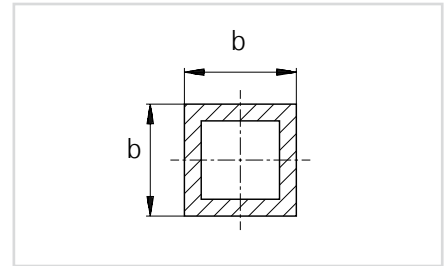

Figure 5-12

Refer to Section on Control in Shaft, Deflection of Shaft and Torsion in Shaft (page 74).
 Also see Intermediate Bearings for prevention of shaft deflection (page 20).

Minimum Diameter of hollowed square Drive Shaft

Metric

$$b \geq 0.48 \times \frac{\sqrt[3]{p_d \times F}}{\sqrt[3]{1 - \left(\frac{a}{b}\right)^4}}$$

Imperial

$$b \geq 0.09 \times \frac{\sqrt[3]{p_d \times F}}{\sqrt[3]{1 - \left(\frac{a}{b}\right)^4}}$$

Hexagon Shaft

Variable Key

- C = Width across flats, mm (in.)
- d_0 = Pitch diameter of drive sprocket, mm (in.)
- F = Tensile force in the chain or belt, N (lbf)

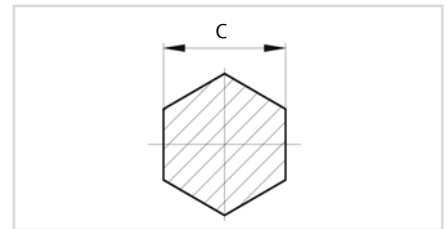

Figure 5-13

Minimum width across flats of Hexagon Drive shaft

Metric

$$c \geq 0.51 \times \sqrt[3]{p_d \times F}$$

Imperial

$$c \geq 0.1 \times \sqrt[3]{p_d \times F}$$

General Calculations

Control of Shaft Deflection of the Shaft under Stress

Variable Key

- u = Deflection, mm (in.)
- F₁ = Shearing force, N (lbf)
- F_B = Tensile force in the belt, N (lbf)
- m_s = Drive shaft weight, kg/mm (lb/ft)
- l₁ = Total shaft length, mm (ft)
- l_s = Shaft length, between outer bearings, mm (in.)
- E* = Modulus of elasticity for shaft material, N/mm² (lbf/in.²)
- I = Inertia force for drive shaft, mm⁴ (in.⁴). See table below.
- C = Force conversion factor. Metric: 9.8; Imperial: 1.0

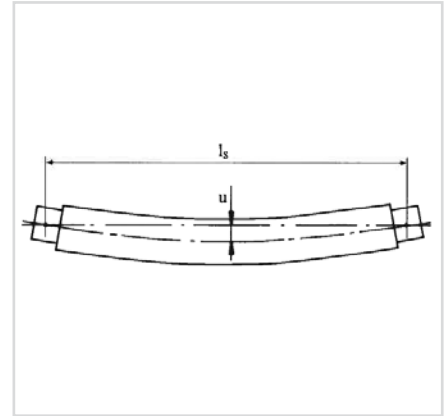

Figure 5-14

* E = 210000 N/mm² for Carbon Steel
 * E = 195000 N/mm² for Stainless Steel
 * E = 70000 N/mm² for Aluminium

| Shaft Type | Inertia Forces |
|---------------|--|
| Round | $I = \frac{\pi \times d^4}{64}$ |
| Hollow Round | $\frac{\pi \times (d^4 - (d - 2 \times t)^4)}{64}$ |
| Square | $I = \frac{b^4}{12}$ |
| Hollow Square | $I = \frac{b^4 - (b - 2 \times t)^4}{12}$ |
| Hexagon | $I = 0.963 \times \left(\frac{c}{2}\right)^4$ |

d = diameter of round shaft
 b = width of square shafts
 t = thickness of the hollowed shaft
 c = width across flats

Find the shearing Force on the Shaft

$$F_1 = \sqrt{F_B^2 + (m_s \times l_1 \times C)^2}$$

Now you can find the Deflection in the Shaft/for 2 Bearings

$$u = \frac{5 \times F_1 \times l_s^3}{384 \times E \times I}$$

For 3 bearings

$$u = \frac{F_1 \times L_s^3}{2960 \times E \times I}$$

The maximum permissible deflection "u" of a shaft is 2.5 mm (0.1 in.)

Torsion in the Shaft under Stress

Variable Key

- ϕ° = Torsion angle. See figure 5-12.
- F_B = Traction in belt, N (lbf)
- p_d = Pitch diameter of drive sprocket, mm (in.)
- l_s = Shaft length, between outer bearings, mm (in.)
- G^* = Modulus in shear of the shaft material, N/mm² (lbf/in.²)
- I_t = Torsional inertia force, mm⁴ (in.⁴). See table below.

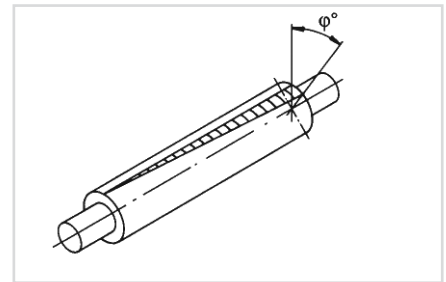

Figure 5-15

- * $G = 80000 \text{ N/mm}^2$ for Carbon Steel
- * $G = 75000 \text{ N/mm}^2$ for Stainless Steel
- * $G = 27000 \text{ N/mm}^2$ for Aluminium

| Shaft Type | Inertia Forces |
|---------------|--|
| Round | $\frac{\pi \times d^4}{32}$ |
| Hollow Round | $I_t = \frac{\pi \times (d^4 - (d - 2 \times t)^4)}{32}$ |
| Square | $I_t = 0.141 \times b^4$ |
| Hollow Square | $I_t = 0.127 \times (b^4 - 2 \times t^4)$ |
| Hexagon | $I_t = 1.847 \times \left(\frac{c}{2}\right)^4$ |

d = diameter of round shaft
 b = width of square shafts
 t = thickness of the hollowed shaft
 c = width across flats

Find the actual Torsion Angle with this Formula

$$\phi^\circ = \frac{90 \times F_B \times p_d \times l_s}{\pi \times G \times I_t}$$

Load Control

Metric

$$\phi^\circ_{\text{permissible}} < \frac{0.5 \times l_s \text{ (mm)}}{1000}$$

Imperial

$$\phi^\circ_{\text{permissible}} < \frac{0.5 \times l_s \text{ (in.)}}{39.37}$$

Installation Guidelines

Assembly instructions for uni-chains belts with various locking systems are available. Please contact uni-chains for these instructions or download them at www.unichains.com

Maintenance Guidelines

Service

All parts of a conveyor should be inspected regularly to ensure the longest wear life possible for chain and wearstrips. The following points should be controlled at the inspection:

1. Examine the chain wear
2. Check that the chain can run freely between the wearstrips, at transfer plates etc.

3. Check the chain for cracks
4. Check the chain for elongation/catenary sag
5. Examine the chain sprockets for wear
6. Examine the wearstrips
7. Check shoes and rollers for wear

Replacement of Conveyor Parts

Chain and belt should be replaced when:

1. The chain has been extended so much that it does not fit the drive sprocket
2. The chain is worn below half the plate thickness
3. The chain surface is worn unevenly
4. The bottom parts of the chain is worn so much that the pins are laid bare. The pins can then damage the wearstrips and other conveyor parts
5. Tab or belt edge is worn on sideflexing belts

Wearstrips should be replaced when:

1. They are worn 50%
2. The surface finish has become rough
3. Hard particles have become embedded into the wearstrip material

Special care must be taken to inspect curved wearstrip sections for wear, since excessive wear can result in the chain pulling out of the conveyor in curves.

Sprockets should be replaced when:

1. The tooth profiles are worn
2. The chain jumps the sprocket

Cleaning Guidelines

Following is a method for cleaning a conveyor. When cleaning a conveyor, always clean top to bottom and from the center out. This will be the most efficient method.

1. Dry Clean

Remove large pieces of debris from the belting/chain. Ensure the sprockets, shafts and supporting features (guide rails, product supports, etc.) are also cleaned of debris.

2. Pre-rinse

Rinse the conveyor system with water heated to 52-54°C (125-130°F) and at a pressure of 150-300 psi (10-20 bar).

3. Apply detergent

Apply selected detergent to the conveyor at a pressure of 150 psi (10 bar). Let the detergent work for 10-15 minutes, but do not let it dry as this can create chemical build up that is harder to remove.

4. Rinse and inspect

Heavily rinse the conveyor at 40-60 psi (2.8-4.1 bar) with water at 52-54°C (125-130°F). Next inspect the conveyor and make sure that debris, detergent, water and other residue have been washed away. Use sight, smell and touch. Care should be taken when using strong detergents.

5. Pre-Op the belt

Re-inspect the conveyor and make sure all chemical detergent has been removed from the conveyor. To ensure this, using pH strips (litmus paper) will ensure that any basic solution has been removed. Run the conveyor slowly to help the conveyor dry and remove pooled water from the surrounding ground while the conveyor is drying.

6. Inspect and release for sanitizing

Inspect the belt again using sensory analysis to detect the presence of bacteria. To verify the presence of bacteria, adenosine triphosphate (ATP) testing should be used. ATP is present in all animal, vegetable, yeast and mold cells. If the ATP testing shows that any of these exist, clean the detected area. Re-lubricate the conveyor if necessary. Next, release the belt for sanitizing.

7. Sanitizing

Running the conveyor again at a slow speed, apply the sanitizer in small concentrations as directed by the manufacturer so that the conveyor does not have to be rinsed. Running the conveyor during this process will ensure that all parts of the conveyor have been exposed to the sanitizer. Clean up any pooled sanitizer and wash it down a drain.

Special conditions

For specific types of machinery, special conditions are valid concerning cleaning. The types of machinery with these conditions are given in the following:

1. Cutting conveyor

The cutting conveyor may be mounted with a Clean In Place (CIP) cleaning device, soaking/rinsing the inside of the conveyor belt via nozzles.

If this is the case, the cutting conveyor must be connected to hot water, min. 70° C, no less than 10 minutes prior to cleaning. The connection is situated at the drive end of the cutting conveyor, Turn on the water, start the cutting conveyor and let it run for no less than 10 minutes. This loosens/rinses off any meat debris on the inside of the belt.

Disconnect the water supply when the cleaning is terminated.

2. Sterilizers

The cleaning instructions for the SMS equipment generally also apply for the sterilizer. However, the following exceptions are to be observed:

Do not use detergent containing acid. Sensors, heaters, etc. should not be cleaned with detergents but can be disinfected according to the current standard.

Specifically heaters where applicable are to be cleaned periodically for lime using acetic or citric acid according to the mixing ratio and instructions stated on the product.

Do not use acetic or citric acid on any other part of the sterilizer, especially not plastic components such as e.g. the lid. Under no circumstances, will these parts stand the influence of acetic or citric acid.

Use a cloth when applying the acid on the heater.

Note: Use protection equipment such as gloves and waterproof clothes. Rinse off with large amounts of water. Application time is given by the instructions on the product in question.

Troubleshooting Guidelines

uni-chains belt systems have been designed to be maintenance free, however, as with all machinery, conveyors can occasionally experience mechanically-related issues that require attention and diagnosis. This guide will serve as assistance in solving any mechanically-related issue that may occur on conveyors using uni-chains belts. If you

require further assistance, information or additional copies of this guide, please contact uni-chains engineering or look at our homepage www.unichains.com. You will also be able to download belt installation and assembly instructions on our website.

Straight running Belts

| Problem | Possible Problems | Solution |
|--|---|--|
| 1. Belt is jumping off the sprockets or not engaging properly | Incorrect catenary sag | Ensure catenary sag on return side of belt is as recommended by uni-chains engineering department or engineering manual. Too much slack can reduce wrap angle or not provide proper back tension on the sprocket |
| - | Incorrect shaft location relative to belt ("A" dimension) | Compare existing shaft location to the recommended A dimension in the uni-chains belt catalog. Adjust drive shaft as necessary to meet these dimensions |
| - | Incorrect belt return design | Ensure belt returnway allows clearance for the necessary catenary sag. If needed adjust return rollers or remove slider return strips to get proper sag. Contact uni-chains engineering for assistance |
| - | Sprockets not aligned correctly with each other | Check that sprocket teeth are aligned with each other across the shaft so that they all engage the belt at the same location. Many sprockets have timing marks that should be placed in alignment all the way across the shaft |
| - | Insufficient belt wrap around drive sprockets | Relocate the first catenary support roller to ensure proper belt wrap around drive sprockets. Check if excess slack in the catenary is causing the wrap angle to be reduced. Remove slack if necessary |
| - | Drive and idle shafts are not parallel with each other | Check the alignment using the methods described in the aligning shafts section of the uni-chains engineering manual. Correct if necessary |
| - | Locked sprocket on drive and idle shafts are not in line with respect to each other | The locked drive and idle sprockets must be in the same location on the shaft relative to each other. Check for alignment and adjust if necessary |
| - | Sprockets are not engaged properly with the belt | Some sprockets have defined travel directions that must be maintained to drive the belt. Some belts have defined sprocket paths. Consult installation guidelines for more information |

Troubleshooting Guidelines

Straight running Belts

| Problem | Possible Problems | Solution |
|--|---|--|
| 2. Excessive belt and/or pin wear | Belts, sprockets or wearstrip exposed to abrasive particles | Eliminate or reduce the exposure of the belt, sprockets or wearstrips to abrasive materials. Replace wearstrip material if it has become embedded with particles |
| - | Incorrect wearstrip material | Ensure wearstrip material is correct for the belt material, load and speed combination as well as environmental conditions. Contact uni-chains for assistance in wearstrip choice |
| - | Binding of belt in the conveyor frame | Examine the conveyor to ensure it is level and square. Look for any concentrated wear points on the belt or frame. These are spots where the belt is rubbing causing wear. Correct the frame to eliminate these contact points |
| - | Incorrect or uneven product loading | Add support under loading area of belt. Take measures to reduce the relative motion between product and belt. If product is side loaded, add an edge guide to opposite side to support the belt |
| - | Excessive belt speed | High speed belts, especially those on shorter length conveyors, will wear more quickly than belts at lower speeds. Reduce belt speed if possible |
| - | Too many backflex and front flex points | The more times the belt hinge must pivot around the pin, the more quickly it will wear. Center drives, take-up systems with multiple rollers, and transition points where the belt goes from horizontal to incline are examples where the belt must front or back flex. The more of these that can be eliminated the less quickly the belt will wear |
| - | Incorrect wearstrip spacing or arrangement | Ensure wearstrip spacing and configuration is optimized for the load on the belt, belt style and environmental conditions. Contact uni-chains engineering for assistance |
| - | Exposed fasteners or other obstructions on carryway or return | Look for points of wear on the belt to get clues to where they are coming from on the conveyor frame. Remove or repair any obstructions |
| - | Sharp corners on carryway or return wearstrips | Be sure the leading edge of any carryway or return wearstrips or other bearing surface are beveled to ensure the belt can move unobstructed |

Straight running Belts

| Problem | Possible Problems | Solution |
|---|---|---|
| <p>3. Belt not tracking properly</p> | <p>Drive and idle shafts are not parallel with each other</p> | <p>Check the alignment using the methods described in the aligning shafts section of the uni-chains engineering manual. Correct if necessary</p> |
| <p>-</p> | <p>Conveyor frame and/or components, not level or square</p> | <p>Check and adjust conveyor frame. After doing this it may be necessary to re-adjust the drive and idle shafts</p> |
| <p>-</p> | <p>Sprockets not aligned correctly with each other</p> | <p>Check that sprocket teeth are aligned with each other across the shaft so that they all engage the belt at the same location. Many sprockets have timing marks that should be placed in alignment all the way across the shaft</p> |
| <p>-</p> | <p>Locked sprocket on drive and idle shafts are not in line with respect to each other</p> | <p>The locked drive and idle sprockets must be in the same location on the shaft relative to each other. Check for alignment and adjust if necessary</p> |
| <p>-</p> | <p>Material build-up on underside of belt interfering with proper sprocket engagement with belt</p> | <p>Remove any material build up that could interfere with sprocket tooth engagement. If possible install an in-place cleaning system or other devices to prevent future material build up</p> |
| <p>-</p> | <p>Sprockets are not engaged properly with the belt</p> | <p>Some sprockets have defined travel directions that must be maintained to drive the belt. Some belts have defined sprocket paths. Consult installation guidelines for more information</p> |
| <p>-</p> | <p>Return rollers or return wearstrips not level and square to conveyor frame</p> | <p>Inspect and correct any return roller or wearstrips that is not level or square with conveyor frame</p> |
| <p>-</p> | <p>Sprockets not properly locked</p> | <p>Check for damaged or missing retainer rings; check retainer ring location to make sure locked sprockets on drive and idle shafts are in perfect alignment. Check that all sprockets are not locked, only the center sprocket</p> |

Troubleshooting Guidelines

Straight running Belts

| Problem | Possible Problems | Solution |
|-----------------------------------|---|---|
| 4. Excessive sprocket wear | Sprockets exposed to abrasive particles | Eliminate or reduce the exposure of the belt, sprockets or wearstrips to abrasive materials |
| - | Incorrect catenary sag | Ensure catenary sag on return side of belt is as recommended by uni-chains engineering department or engineering manual. Too much slack can reduce wrap angle or not provide proper back tension on the sprocket |
| - | Excessive belt speed | Reduce belt speed if possible |
| - | Drive and idle shafts are not parallel with each other | Check the alignment using the methods described in the aligning shafts section of the uni-chains engineering manual. Correct if necessary |
| - | Insufficient number of sprockets | Sprocket wear is proportional to tooth contact area. More sprockets provide more tooth contact which will reduce wear. Also using a sprocket with a larger number of teeth will increase contact area |
| - | Locked sprocket on drive and idle shafts are not in line with respect to each other | The locked drive and idle sprockets must be in the same location on the shaft relative to each other. Check for alignment and adjust if necessary |
| - | Sprockets not aligned correctly with each other | Check that sprocket teeth are aligned with each other across the shaft so that they all engage the belt at the same location. Many sprockets have timing marks that should be placed in alignment all the way across the shaft |
| - | Incorrect shaft location relative to belt ("A" dimension) | Compare existing shaft location to the recommended A dimension in the uni-chains belt catalog. Adjust drive shaft as necessary to meet these dimensions |
| - | Shaft deflection or twisting | Examine shaft for evidence of deflection or twisting. These conditions prevent all the sprockets from pulling evenly on the belt. Bent or twisted shafts should be replaced. An intermediate bearing may be used to address deflection for wide belts. Check the tension calculation to determine if a larger shaft is necessary. Contact uni-chains engineering for assistance |

Troubleshooting Guidelines

Straight running Belts

| Problem | Possible Problems | Solution |
|--------------------------------|---|--|
| 5. Wear or damage on belt edge | Belt edge catching on obstructions on carryway, return, frame or nearby equipment | Examine the conveyor frame and belt sliding surfaces for any catch points and correct any of these conditions |
| - | Belt not properly aligned or not tracking correctly | Improper alignment or tracking can cause the belt to pull to one side and contact the frame edge or other obstructions. Refer to belt tracking section of this guide for methods to correct this |
| - | Thermal expansion causing belt edge to contact the conveyor frame | Ensure the frame provides the proper minimum clearance on each side of the belt when full thermal expansion (highest temperature) is reached |
| - | Conveyor frame and/or components, not level or square | Check and adjust conveyor frame to correct any contact points with the belt. After doing this it may be necessary to re-adjust the drive and idle shafts |
| - | Drive and idle shafts are not parallel with each other | This can cause the belt to mistrack to one side. Check the alignment using the methods described in the aligning shafts section of the uni-chains engineering manual. Correct if necessary |
| - | Belt edge not properly supported | If belt edge is cantilevered out over the support it can cause breakage if product is loaded at that point. Also uni-chains belts in many materials are buoyant in many liquids and it may be necessary to guide the belt in these cases to prevent edge wear. Contact uni-chains engineering for assistance |

Troubleshooting Guidelines

Straight running Belts

| Problem | Possible Problems | Solution |
|--|--|---|
| 6. Sprockets move laterally to center or edge of belt | Drive and idle shafts are not parallel with each other | This can create a side force in the belt against the sprockets. Check the alignment using the methods described in the Aligning Shafts section of the engineering manual. Correct uni-chains if necessary |
| - | Sprockets not properly locked | Check for damaged or missing retainer rings; check retainer ring location to make sure locked sprockets on drive and idle shafts are in perfect alignment. Check that all sprockets are not locked, only the center sprocket |
| - | Locked sprocket on drive and idle shafts are not in line with respect to each other | The locked drive and idle sprockets must be in the same location on the shaft relative to each other. Check for alignment and adjust if necessary |
| - | Sprockets not aligned correctly with each other | Check that sprocket teeth are aligned with each other across the shaft so that they all engage the belt at the same location. Many sprockets have timing marks that should be placed in alignment all the way across the shaft |
| - | Material build-up on underside of belt interfering with proper sprocket engagement with belt | Remove any material build up that could interfere with sprocket tooth engagement. If possible install an in-place cleaning system or other devices to prevent future material build up |
| - | Sprockets are not engaged properly with the belt | Some sprockets have defined travel directions that must be maintained to drive the belt. Some belts have defined sprocket paths. Consult installation guidelines for more information |
| - | Shaft deflection or twisting | Examine shaft for evidence of deflection or twisting. These conditions prevent all the sprockets from pulling evenly on the belt. Bent or twisted shafts should be replaced. An intermediate bearing may be used to address deflection for wide belts. Check the tension calculation to determine if a larger shaft is necessary. Contact uni-chains engineering for assistance |

Troubleshooting Guidelines

Straight running Belts

| Problem | Possible Problems | Solution |
|---|--|---|
| 7. Hinge pin migrating out of belt | Locking system not secure | Refer to assembly instructions for details on the various locking systems and how to properly apply them |
| - | Belt edge is contacting side frame or other obstruction | This can cause a repeated hammering force on the pin from the side of the belt making contact. Find this area(s) and eliminate the contact |
| - | Drive and idle shafts are not parallel with each other | This can cause the belt to mistrack to one side and apply a side force to the pins. Check the alignment using the methods described in the Aligning Shafts section of the uni-chains engineering manual. Correct if necessary |
| 8. Side guard wear, damage, or breakage | Side guards contacting conveyor frame, return or nearby equipment | Eliminate any obstructions to sideguard travel. Examine the conveyor frame for possible contact points |
| - | Incorrect or uneven product loading | Add support under loading area of belt. Correct any belt loading method that may cause damage to sideguards. Take measures so the conveyed material is moving at a similar speed and direction to the belt when it is loaded |
| 9. Product support wear, damage, or breakage | Product supports contacting obstructions on conveyor frame, return or nearby equipment | Eliminate obstructions to the product support travel. Examine the conveyor frame for any possible contact points and correct any conditions restricting the travel of the product support |
| - | Incorrect or uneven product loading | Adjust belt loading as necessary to protect product supports. Take measures so the conveyed material is moving at a similar speed and direction to the belt when it is loaded |
| - | Large impact at the infeed area | Reduce impact directly on belt by adding an "impact plate" above belt to absorb initial shock. Mount this plate at an angle that will direct impacting product onto the belt |
| - | Improper return support for product supports | Belts with product supports should be supported on each side of belt, usually on the indent and also as needed across the belt width. Refer to return section of this manual or contact uni-chains engineering for assistance |

Troubleshooting Guidelines

Straight running Belts

| Problem | Possible Problems | Solution | |
|----------------------------------|-------------------------------------|--|---|
| 10. Impact damage to belt | Incorrect or uneven product loading | Adjust belt loading as necessary to protect product supports. Take measures so the conveyed material is moving at a similar speed and direction to the belt when it is loaded | |
| | - | Unsuitable belt material | Some materials have better impact properties than others. Refer to the materials section of the uni-chains engineering manual or contact uni-chains engineering for assistance |
| | - | Environmental factors | Environmental factors can adversely affect impact resistance of a plastic belt. Chemicals make plastic more brittle and plastic becomes less impact resistant at low temperatures. Look to reduce or eliminate these conditions or contact uni-chains engineering for belt/material alternatives |
| 11. Finger plate damage | Improper mounting of finger plates | Refer to Design Guidelines in the uni-chains engineering manual for correct mounting criteria. Finger plates must be free to move laterally with the belt as it expands and contracts. It is important the angle used to mount the finger plates is straight, level, and not twisted or bent | |
| | - | Excessive heat at finger plate area | If belts in a high heat area are expanding beyond the movement range of the finger plate's slotted mounting holes, contact uni-chains engineering for assistance |
| | - | Raised Rib belt not tracking correctly | Correct belt tracking problem as explained in #3 |
| | - | Material build up between raised ribs | Clean the existing debris from belt and eliminate the source of build up if possible. Routinely examine and clean belt as a preventative measure |
| | - | Incorrect shaft location relative to belt ("A" dimension) | Compare existing shaft location to the recommended A dimension in the uni-chains belt catalog. Adjust drive shaft as necessary to meet these dimensions |
| | - | Shaft deflection or twisting | Examine shaft for evidence of deflection or twisting. Bent or twisted shafts should be replaced. An intermediate bearing may be used to address deflection for wide belts. Check the tension calculation to determine if a larger shaft is necessary. Contact uni-chains engineering for assistance |
| | - | Sprockets not aligned correctly with each other | Check that sprocket teeth are aligned with each other across the shaft so that they all engage the belt at the same location. Many sprockets have timing marks that should be placed in alignment all the way across the shaft |

Troubleshooting Guidelines

Straight running Belts

| Problem | Possible Problems | Solution |
|--|--|--|
| <p>12. Belt develops excessive catenary sag</p> | <p>Incorrect total belt length</p> | <p>Excess catenary sag must occur at the belt's coldest operating temperature because this is when the belt will be contracted to its shortest length. If excess catenary is found, shorten the belt by removing rows of modules</p> |
| <p>-</p> | <p>Insufficient belt take-up in high heat applications</p> | <p>If the catenary sag is due to extra length from the thermal expansion from operational temperatures and is not excessive when cold, it may be necessary to add a take-up device on the conveyor to compensate for the thermal growth. Contact uni-chains engineering for assistance</p> |
| <p>-</p> | <p>Elongation of belt due to initial start-up situation or heavy loads</p> | <p>Plastic belt will elongate during initial use. This is a normal process that is a function of the belt modules and pins seating themselves with each other and is more noticeable when heavy loads are present. In this case, allow belt to adjust to operating conditions and shorten when necessary by removing rows of modules</p> <p><i>CAUTION: Monitor belt during initial use to avoid binding or catching</i></p> |
| <p>-</p> | <p>-</p> | <p>-</p> |
| <p>-</p> | <p>-</p> | <p>-</p> |
| <p>-</p> | <p>-</p> | <p>-</p> |
| <p>-</p> | <p>-</p> | <p>-</p> |
| <p>-</p> | <p>-</p> | <p>-</p> |

Troubleshooting Guidelines

Sideflexing Belts

| Problem | Possible Problems | Solution |
|---|---|---|
| 1. Belt is jumping off the sprockets or not engaging properly | Incorrect catenary sag | Ensure catenary sag on return side of belt is as recommended by uni-chains engineering department or engineering manual. Too much slack can reduce wrap angle or not provide proper back tension on the sprocket |
| - | Belt length changes not accommodated | Belt length can increase with temperature, load, and wear. This excess belt will accumulate right after the drive sprockets where the tension is lowest. Too much catenary sag reduces the wrap on the sprocket or can cause the belt to bounce up off the sprockets. A snub roller can help isolate this from the drive sprockets. Sometimes a take-up system, prior to the first turn, may be required |
| - | Straight section from curve to drive shaft does not meet minimum requirements | If this straight section is too short, the belt pull will not be evenly distributed across the belt width. This causes two main problems: 1) the belt will have a slightly different pitch and phase from one side to the other, and 2) the belt will tend to migrate to the outside of the last curve, placing a significant side load on the sprockets. Refer to the uni-chains belt catalog and engineering manual for these minimum requirements for each sideflexing belt series |
| - | Belt edge not properly supported leading to the drive sprockets | Coming out of a curve a belt will have a natural tendency to "walk" to the outside edge, even if minimum requirements are met. To prevent the sprockets from having to resist this side force, an edge guide should be installed on the outside edge of the belt leading to the drive shaft. This guide should not force the belt to the inside; rather, it should keep the belt perpendicular to the last curve |
| - | Return and carryway sections not parallel with each other | This creates a situation where the sprocket rotation is not in line with the belt travel, which will cause side loads on the sprockets. This can cause the sides of the sprocket teeth to wear or the belt to disengage with the sprockets |
| - | Drive shaft is not perpendicular to curve outlet | This creates the same condition as when the drive and tail shaft are not parallel on straight belts. If the drive does not pull the belt straight out of the curve, the load is not evenly distributed on the sprockets. Check shaft alignment with the curve and adjust if necessary |

Troubleshooting Guidelines

Sideflexing Belts

| Problem | Possible Problems | Solution |
|---|---|---|
| 2. Excessive wear on the guide rail wearstrip, especially in turns | Wearstrip material's PV value is exceeded | In sideflexing belts there is a great inward radial load in the curve, especially at the transitions between straight and curve sections. At the point of contact between belt and wearstrip heat will occur due to friction. The combination of this pressure and the velocity (PV Limit) of the conveyor may be too much for the particular wearstrip material. A PV overload is often characterized by a sharp temperature rise in these sections of the conveyor. A wearstrip material with a higher PV may be used, but care should be taken because at some point the wearstrip will stop wearing and the belt edge will start to wear. We advise replacement of wearstrip rather than belt |
| - | Not enough guide clearance for belt through the section in question | If the edge guides force the belt to bind through a section, additional compressive forces are applied to the wearstrip (as well as additional tensile forces in the belt). Before the installation of a belt, take a 2-3 in. long section of belt and manually pull it through all sections and wearstrip to insure proper guide clearance |
| - | Edge guide wearstrips through the turn not smooth, even or continuous | An edge guide that is not smooth can create high radial forces, causing higher loads on the wearstrip and the belt. This condition is often characterized by higher temperatures on this wearstrip than in other sections. Ensure that all guide rails form a smooth, continuous arc for any curve |
| 3. Excessive sprocket wear | Belt edge not properly supported leading to the drive sprockets | Coming out of a curve, a belt will have a natural tendency to "walk" to the outside edge, even if minimum requirements are met. To prevent the sprockets from having to resist this side force, an edge guide should be installed on the outside edge of the belt leading to the drive shaft. This guide should not force the belt to the inside; rather, it should keep the belt perpendicular to the last curve |
| - | Return and carryway sections not parallel with each other | This creates a situation where the sprocket rotation is not in line with the belt travel, which will cause side loads on the sprockets. This can cause the sides of the sprocket teeth to wear or the belt to disengage with the sprockets |
| - | Drive shaft is not perpendicular to curve outlet | This creates the same condition as when the drive and tail shaft are not parallel on straight belts. If the drive does not pull the belt straight out of the curve, the load is not evenly distributed on the sprockets. Check shaft alignment with the curve and adjust if necessary |

Troubleshooting Guidelines

Sideflexing Belts

| Problem | Possible Problems | Solution |
|--|--|---|
| 4. Excessive belt edge wear or breakage | There is a catch point on the supports or hold down wearstrip that is snagging an edge | The support wearstrip must be in contact with the belt, but it should be free from catch points or sharp leading edges. If an outer hold down wearstrip is used, care should be taken that it does not catch the belt which can cause edge damage. The outer hold down must be placed so that there is running clearance between it and the belt at the maximum operating temperature of the belt |
| - | Improper guide rail wearstrip material | If extreme wear is not apparent on the wearstrip, it may have too high of a PV limit in relation to the belt. If the wearstrip is made from a high PV material such as Nylatron, a UHMW (plain or lubricated) may need to be used. It is preferable to replace wearstrip, rather than belts |
| 5. Hinge pin migrating out of belt | Locking system not secured | Refer to assembly instructions for details on the various locking systems and how to properly apply them |
| - | The belt edge damaged from a catch point or wear | Examine the belt edge for damage that is affecting the locking system. If it is from a catch point, replace the damaged modules and examine the frame for cause of the snag |
| - | - | - |
| - | - | - |
| - | - | - |
| - | - | - |

Conveyors with Turn discs

A turn disc assembly is a disc mounted on a steel shaft with bearings that allow the disc to turn freely. This free spinning disc replaces the inside sliding bearing surface of a curve to reduce the tension on the belt or chain. This is often used to make multiple curves with one single drive station or to pull more load around a curve. Turn discs can be used with both belts and chains. However they are most commonly used with chains because of the typically smaller radius and the fact that the radius does not change with the chain width as it does with a belt. uni-chains offers a range of turn discs for use with certain slat top chains and, although turn discs for belts are not offered, uni-chains' engineering can assist you in designing a turn disc for a sideflexing belt.

Turn discs can be supplied as a single disc (just for the carryway) figure 7-3 or as a double disc figure 7-2 (for both carryway and return). They can be supplied as a sin-

gle or double disc complete with the UHMW curve tracks figure 7-4 and figure 7-5 or they can be supplied without the tracks figure 7-2 and figure 7-3. The disc material is black glass reinforced nylon and the shaft material is 304SS.



Figure 7-1

Turn Disc Assemblies without Tracks

| Do/Si | Chain Type | Item No. | Dimensions (mm) | | |
|-------|------------|----------|-----------------|-------|-----|
| | | | F | H | O |
| Do | 880T-R | 94600 | 80 | 209 | 80 |
| Do | 880T-RT | 94601 | 84 | 209 | 76 |
| Do | 1700 | 94603 | 60 | 209 | 100 |
| Do | 1701T | 94602 | 76 | 209 | 100 |
| Si | 880T-R | 94500 | - | 131.5 | 85 |
| Si | 880T-RT | 94501 | - | 131.5 | 85 |
| Si | 1700 | 94503 | - | 131.5 | 85 |
| Si | 1701T | 94502 | - | 131.5 | 85 |

Note: Do = Double disc; Si = Single disc

Double Turn Disc Assemblies without Tracks

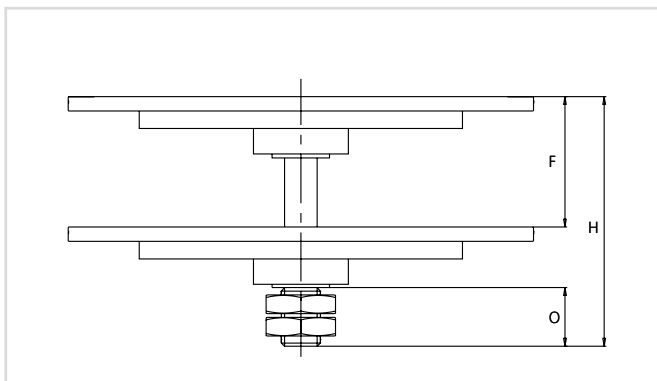

Figure 7-2

Single Turn Disc Assemblies without Tracks

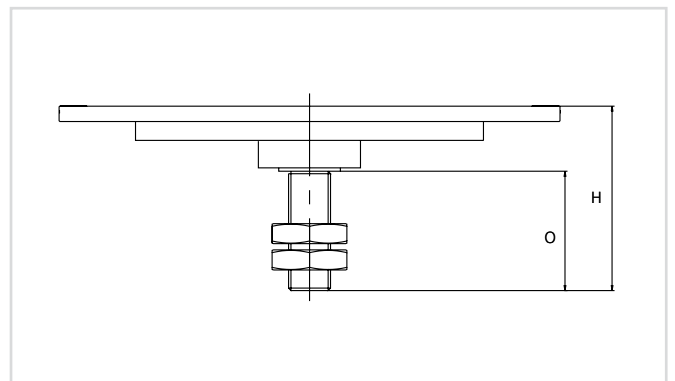

Figure 7-3

Conveyors with Turn Discs

Turn Disc Assemblies complete with Curve Tracks

| Do/Si | Chain Type | Track type | Curve Angle | Item No. | Dimensions (mm) | | | | | | |
|-------|-------------|------------|-------------|----------|-----------------|----|-------|-----|----|-------|-------------|
| | | | | | O | E | H | C | T | W | Lead in/out |
| Do | 880T-K325R | Curve | 90° | 94800 | 80 | 90 | 209.0 | 200 | 25 | 475 | 225 |
| Do | 880T-K325R | Curve | 180° | 94801 | 80 | 90 | 209.0 | 200 | 25 | 500 | 225 |
| Do | 880T-K450R | Curve | 90° | 94810 | 80 | 90 | 209.0 | 200 | 25 | 487.5 | 225 |
| Do | 880T-K450R | Curve | 180° | 94811 | 80 | 90 | 209.0 | 200 | 25 | 525 | 225 |
| Do | 880T-K325RT | Curve | 90° | 94802 | 76 | 90 | 209.0 | 200 | 25 | 487.5 | 225 |
| Do | 880T-K325RT | Curve | 180° | 94803 | 76 | 90 | 209.0 | 200 | 25 | 525 | 225 |
| Do | 880T-K450RT | Curve | 90° | 94812 | 76 | 90 | 209.0 | 200 | 25 | 487.5 | 225 |
| Do | 880T-K450RT | Curve | 180° | 94813 | 76 | 90 | 209.0 | 200 | 25 | 525 | 225 |
| Do | 1700 | Curve | 90° | 94806 | 100 | 90 | 209.0 | 150 | 30 | 400 | 200 |
| Do | 1700 | Curve | 180° | 94807 | 100 | 90 | 209.0 | 150 | 30 | 400 | 200 |
| Do | 1701T | Curve | 90° | 94804 | 74 | 90 | 209.0 | 150 | 30 | 400 | 200 |
| Do | 1701T | Curve | 180° | 94805 | 74 | 90 | 209.0 | 150 | 30 | 400 | 200 |
| Si | 880T-K325R | Curve | 90° | 94700 | 85 | - | 131.5 | 200 | 25 | 475 | 225 |
| Si | 880T-K325R | Curve | 180° | 94701 | 85 | - | 131.5 | 200 | 25 | 500 | 225 |
| Si | 880T-K450R | Curve | 90° | 94710 | 85 | - | 131.5 | 200 | 25 | 487.5 | 225 |
| Si | 880T-K450R | Curve | 180° | 94711 | 85 | - | 131.5 | 200 | 25 | 525 | 225 |
| Si | 880T-K325RT | Curve | 90° | 94702 | 85 | - | 131.5 | 200 | 25 | 475 | 225 |
| Si | 880T-K325RT | Curve | 180° | 94703 | 85 | - | 131.5 | 200 | 25 | 500 | 225 |
| Si | 880T-K450RT | Curve | 90° | 94708 | 85 | - | 131.5 | 200 | 25 | 487.5 | 225 |
| Si | 880T-K450RT | Curve | 180° | 94709 | 85 | - | 131.5 | 200 | 25 | 525 | 225 |
| Si | 1700 | Curve | 90° | 94706 | 85 | - | 131.5 | 150 | 30 | 400 | 200 |
| Si | 1700 | Curve | 180° | 94707 | 85 | - | 131.5 | 150 | 30 | 400 | 200 |
| Si | 1701T | Curve | 90° | 94704 | 85 | - | 131.5 | 150 | 30 | 400 | 200 |
| Si | 1701T | Curve | 180° | 94705 | 85 | - | 131.5 | 150 | 30 | 400 | 200 |

Note: Do = Double disc; Si = Single disc

Double Turn Disc Assemblies complete with Curve Tracks

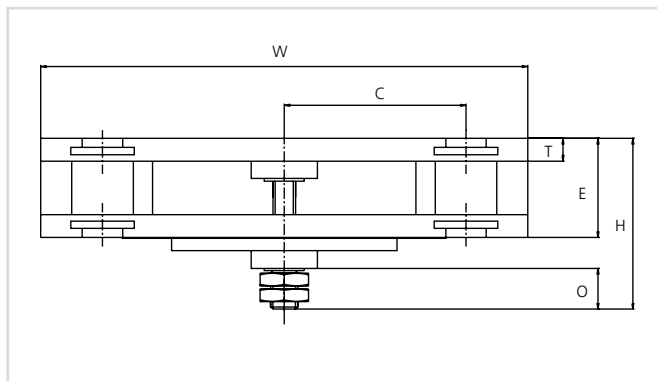

Figure 7-4

Single Turn Disc Assemblies complete with Curve Tracks

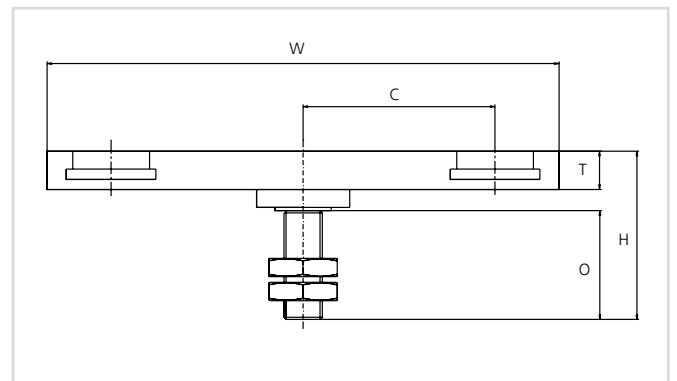

Figure 7-5

Conversion of Units (metric/imperial)

| Imperial | Multiply | Metric | Multiply | Imperial |
|---------------------|----------|----------------------------|-----------|---------------------|
| Length | | | | |
| inch (in.) | 25.4 | millimeter (mm) | 0.03937 | inch (in.) |
| inch (in.) | 0.0254 | meter (m) | 39.37 | inch (in.) |
| foot (ft.) | 304.8 | millimeter (mm) | 0.0033 | foot (ft.) |
| foot (ft.) | 0.3048 | meter (m) | 3.281 | foot (ft.) |
| Area | | | | |
| square inch | 645.2 | square millimeter | 0.00155 | square inch |
| square inch | 0.000645 | square meter | 1550 | square inch |
| square foot | 92,903 | square millimeter | 0.00001 | square foot |
| square foot | 0.0929 | square meter | 10.764 | square foot |
| Volume | | | | |
| cubic foot | 0.0283 | cubic meter | 35.31 | cubic foot |
| cubic foot | 28.32 | liter | 0.0353 | cubic foot |
| Velocity and Speed | | | | |
| foot/second | 18.29 | meter/min | 0.0547 | foot/second |
| foot/minute | 0.3048 | meter/min | 3.281 | foot/second |
| Mass and Density | | | | |
| pound | 0.4536 | kilogram | 2.205 | pound |
| pound/cubic foot | 16.02 | kilogram/cubic meter | 0.0624 | pound/cubic foot |
| Force | | | | |
| pound-force | 0.4536 | kilogram-force | 2.205 | pound-force |
| pound-force | 4.448 | newton | 0.225 | pound-force |
| kilogram-force | 9.807 | newton | 0.102 | kilogram-force |
| Work (Force/Length) | | | | |
| pound/foot | 1.488 | kilogram/meter | 0.672 | pound/foot |
| pound/foot | 14.59 | newton/meter | 0.0685 | pound/foot |
| kilogram/meter | 9.807 | newton/meter | 0.102 | kilogram/meter |
| Torque | | | | |
| inch-pound | 11.52 | kilogram-millimeter | 0.0868 | inch-pound |
| inch-pound | 0.113 | newton-meter | 8.85 | inch-pound |
| kilogram-millimeter | 9.81 | newton/millimeter | 0.102 | kilogram-millimeter |
| Moment of Inertia | | | | |
| inch ⁴ | 416,231 | millimeter ⁴ | 0.0000024 | inch ⁴ |
| inch ⁴ | 41.62 | centimeter ⁴ | 0.024 | inch ⁴ |
| Pressure | | | | |
| pound/square inch | 0.0007 | kilogram/square millimeter | 1422 | pound/square inch |
| pound/square inch | 0.0703 | kilogram/square millimeter | 14.22 | pound/square inch |
| pound/square inch | 0.00689 | newton/millimeter | 145 | pound/square inch |
| pound/square inch | 0.689 | newton/millimeter | 1.45 | pound/square inch |
| Stress | | | | |
| pound/square foot | 4.882 | kilogram/square meter | 0.205 | pound/square foot |
| pound/square foot | 47.88 | newton/square meter | 0.0209 | pound/square foot |
| Power | | | | |
| horsepower | 745.7 | watt | 0.00134 | horsepower |
| foot-pound/minute | 0.0226 | watt | 44.25 | foot-pound/minute |

Calculation Factors

Values provided in the tables below are dynamic friction under clean conditions. Values will be 0.1 to 0.2 higher

at the starting moment. If possible it is recommended to start the conveyor unloaded and gradually apply load.

Friction Coefficient (μ_1) between Chain/Belt and Wearstrip

| Chain/Belt Material | Wearstrip Material | | | | | |
|---------------------|--------------------|------------|-----------------|------------------|--------------|--------------|
| | UHMWPE Dry | UHMWPE Wet | UHMWPE with Oil | Nylatron NSM Dry | SS-Steel Dry | SS-Steel Wet |
| POM-NL | 0.20 | 0.15 | 0.12 | 0.22 | 0.25 | 0.21 |
| POM-D | 0.19 | 0.14 | 0.12 | 0.21 | 0.24 | 0.20 |
| POM-LF | 0.18 | 0.13 | 0.12 | 0.20 | 0.23 | 0.19 |
| POM-SLF | 0.17 | 0.12 | 0.12 | 0.19 | 0.22 | 0.18 |
| POM-SX | 0.15 | 0.10 | 0.11 | 0.17 | 0.20 | 0.16 |
| PP | 0.25 | 0.20 | 0.15 | 0.28 | 0.30 | 0.27 |
| PE | 0.25 | 0.20 | 0.15 | 0.28 | 0.25 | 0.20 |
| PA6 | 0.20 | N/a | 0.15 | 0.22 | 0.30 | n/a |
| GR | 0.26 | 0.22 | 0.18 | 0.29 | 0.32 | 0.25 |
| AR | 0.26 | 0.22 | 0.18 | 0.29 | 0.32 | 0.25 |

Friction Coefficient, (μ_2) between Chain/Belt and Product

| Chain Material | Lubrication | Product Material | | | |
|-----------------------------|--------------|------------------|-------|---------|-----------|
| | | Glass | Metal | Plastic | Cardboard |
| Carbon*/ Stainless Steel | Water | 0.25 | 0.25 | 0.20 | - |
| | Water + soap | 0.15 | 0.15 | 0.10 | - |
| | Oil | 0.15 | 0.15 | 0.10 | - |
| POM-D (Acetal) | Dry | (0.18) | 0.24 | 0.22 | 0.27 |
| | Water | (0.16) | 0.21 | 0.19 | - |
| POM-LF (Acetal) | Dry | (0.15) | 0.20 | 0.18 | 0.21 |
| | Water | (0.12) | 0.18 | 0.16 | - |
| POM-SLF (Acetal) | Dry | (0.12) | 0.15 | 0.15 | 0.19 |
| | Water | (0.10) | 0.14 | 0.14 | - |
| AR/GR | Dry | (0.27) | 0.32 | 0.26 | 0.31 |
| | Water | (0.25) | 0.30 | 0.25 | - |
| PP | Dry | (0.19) | 0.32 | 0.17 | 0.22 |
| | Water | (0.17) | 0.30 | 0.15 | - |
| PE | Dry | (0.10) | 0.13 | 0.10 | 0.15 |
| | Water | (0.09) | 0.11 | 0.09 | - |

Note: Carbon chains can not run with water.
 (): Do not use plastic chains if broken glass comes on the conveyor.
 For uni PRR chains, use μ_1 .

Calculation Factors

Service Factors (SF)

| Conveyor Condition/ Start-Stop per hour | Straight Conveyor | Incline/Decline Conveyor | Curve Conveyor |
|--|-------------------|--------------------------|----------------|
| Clean 0-4/hour | 1.0 | 1.2 | 1.4 |
| Clean 5 or more/hour | 1.2 | 1.3 | 1.5 |
| Average 0-4/hour | 1.2 | 1.4 | 1.5 |
| Average 5 or more/hour | 1.4 | 1.5 | 1.6 |
| Dirty 0-4/hour | 1.4 | 1.6 | 1.8 |
| Dirty 5 or more/hour | 1.5 | 1.7 | 1.9 |

Speed Factors (C_S)

| | |
|-----------------|------|
| 0-20 m/min | 1.00 |
| at 30 m/min | 0.85 |
| at 45 m/min | 0.75 |
| at 60 m/min | 0.70 |
| above 120 m/min | 0.65 |

Note: Speed factor can be used for all belts and chains. For sideflexing belts, please check load/speed relations first and only use speed factor if the load/speed relation for your particular belt/weartrip combination is not listed.

Temperature Factors (C_T)

| | POM | PP | PE | PA6.6 | PA6.6-GFH |
|-----------|------|------|------|-------|-----------|
| at -79 °C | n/a | n/a | 1.35 | n/a | n/a |
| at -40 °C | 1.05 | n/a | 1.30 | 1.10 | 1.00 |
| 1 °C | 1.05 | 1.00 | 1.10 | 1.05 | 1.00 |
| 20 °C | 1.00 | 1.00 | 1.00 | 1.00 | 1.00 |
| 40 °C | 0.95 | 0.85 | 0.50 | 0.90 | 1.00 |
| 60 °C | 0.90 | 0.60 | 0.40 | 0.55 | |
| 80 °C | 0.60 | 0.40 | 0.25 | 0.30 | |
| 90 °C | 0.40 | 0.35 | n/a | 0.25 | |
| 100 °C | n/a | 0.25 | n/a | 0.20 | |
| 120 °C | n/a | n/a | n/a | 0.17 | |
| 140 °C | n/a | n/a | n/a | 0.16 | |
| 160 °C | n/a | n/a | n/a | n/a | |
| 180 °C | n/a | n/a | n/a | n/a | |

Calculation Factors

Curve Factor (K)/Inclination Factor (K_{inc})

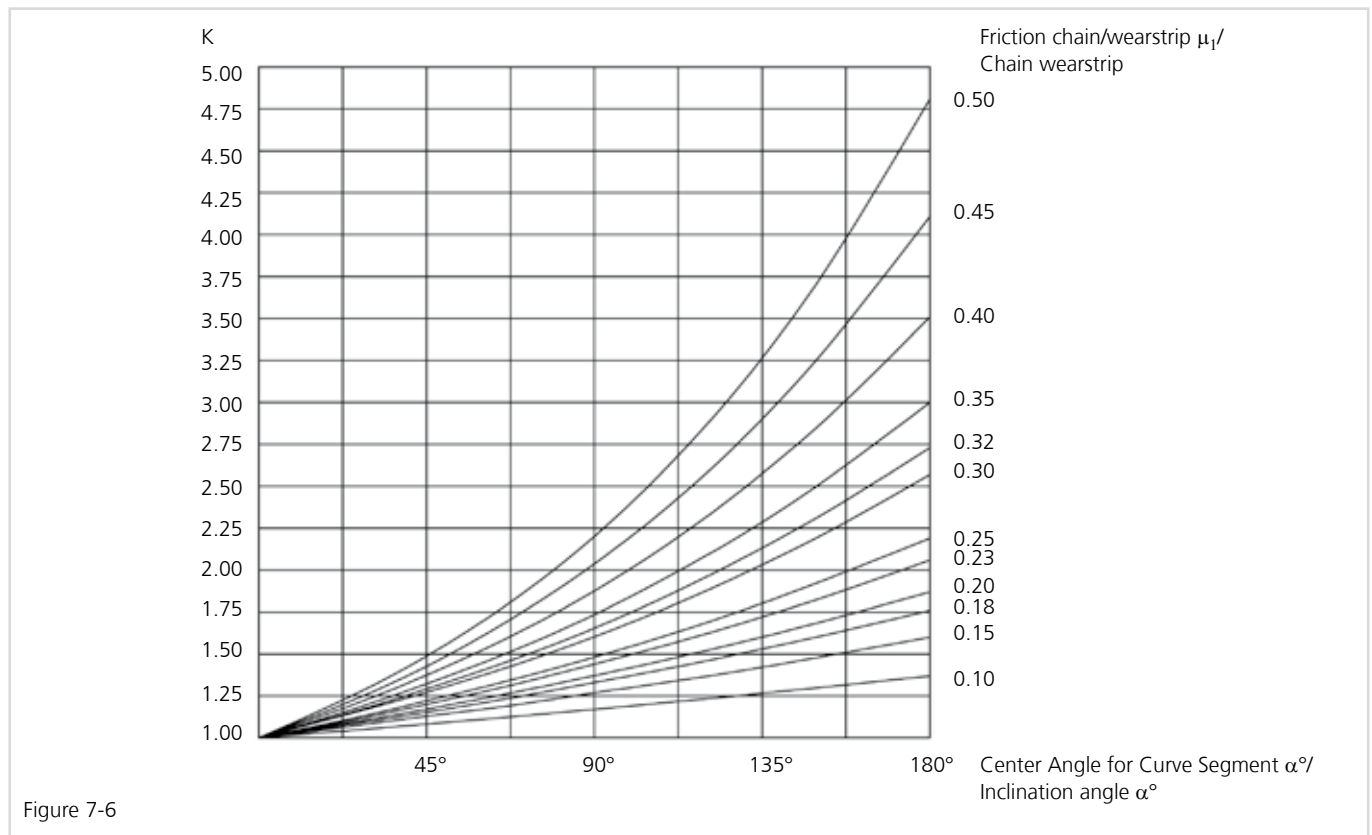

Figure 7-6

The curve factor/inclination factor can also be calculated using the following formula:

$$K = e^{\left(\frac{\mu_1 \times \alpha \times \pi}{180}\right)} \approx 2.72^{\left(\frac{\mu_1 \times \alpha \times \pi}{180}\right)}$$

α = Curve/incline angle in degrees

μ_1 = Friction coefficient, belt/chain wearstrip

e = Mathematical constant, $e \approx 2.72$

Load/Speed Relations

Load/Speed Relations for uni Flex SNB with Nylatron Wearstrips

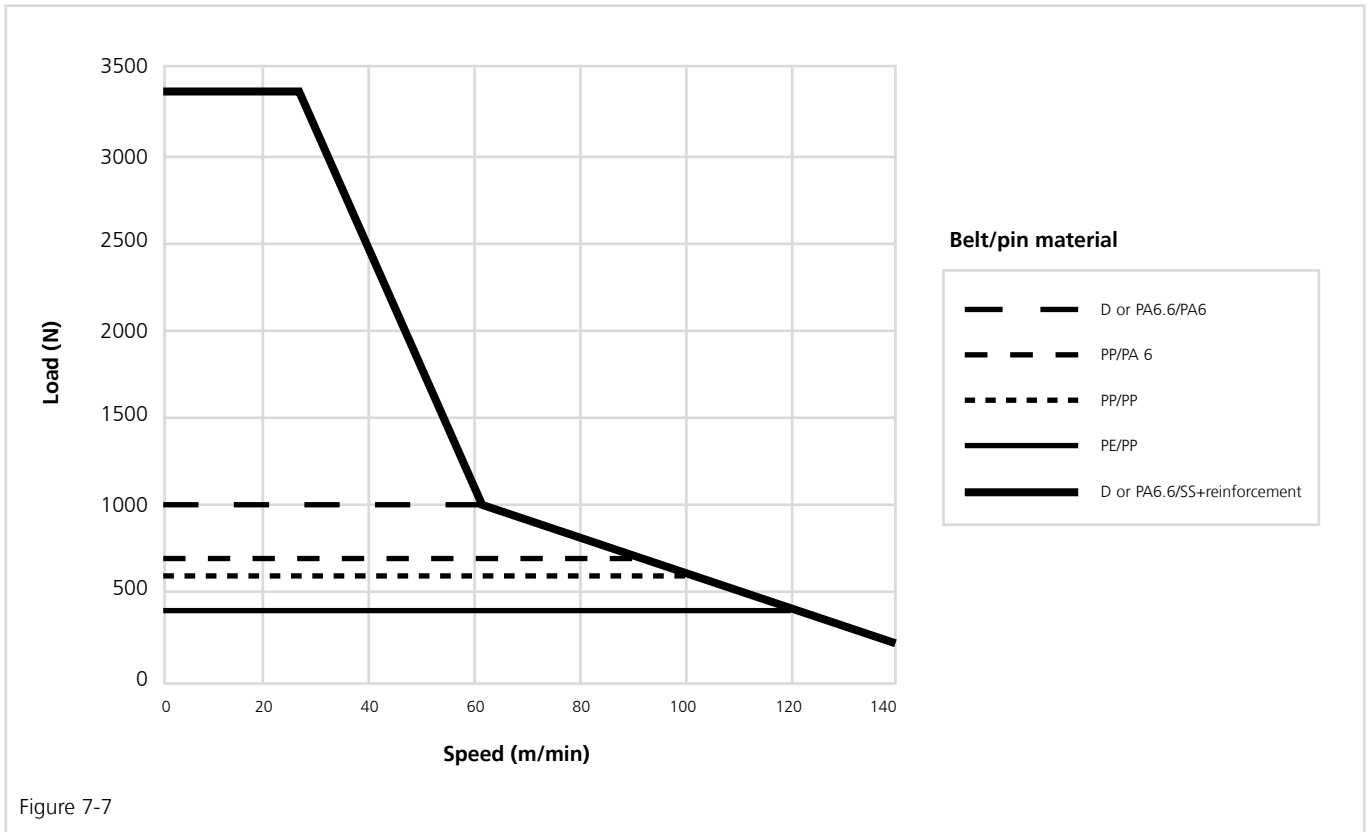

Figure 7-7

Load/Speed Relations for uni Flex SNB with HD 1000 Wearstrips

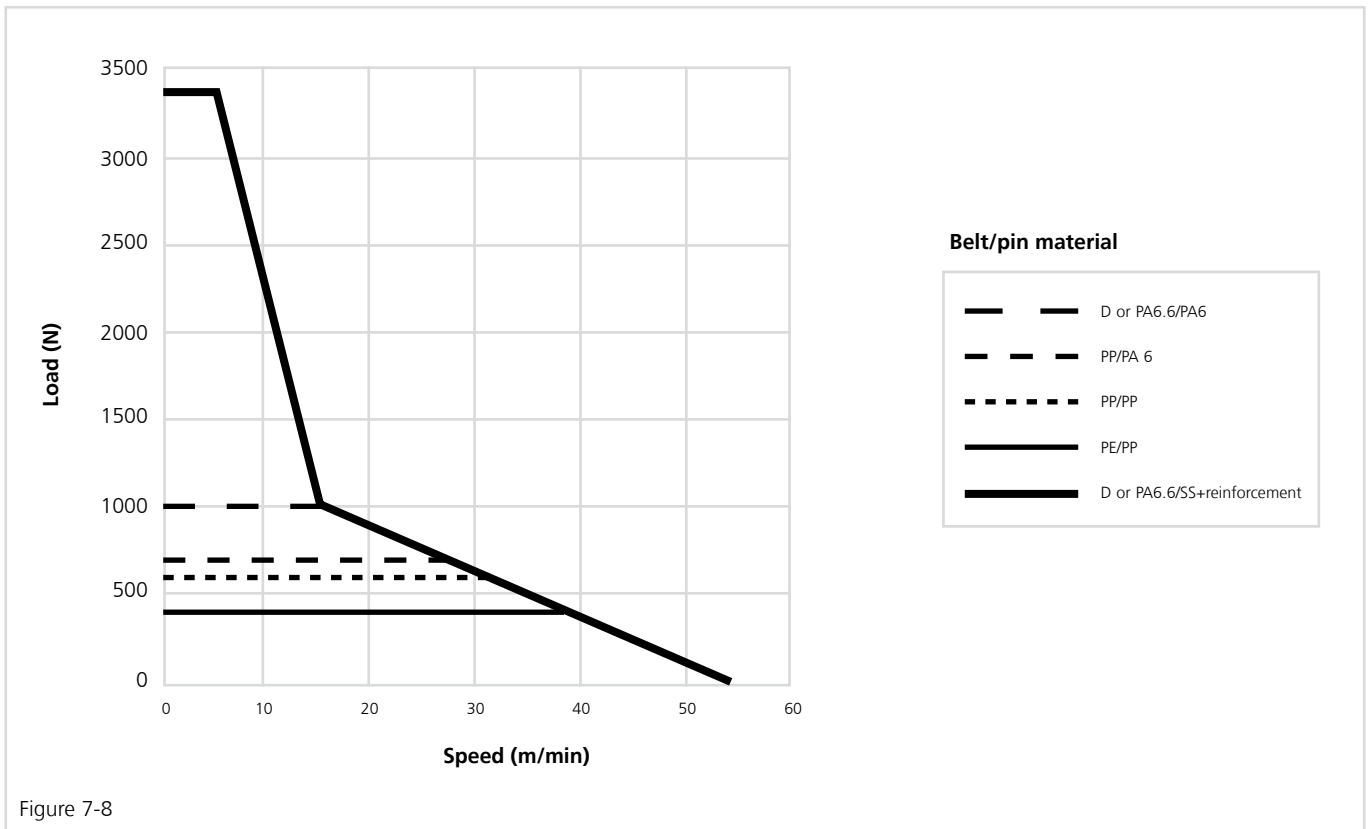

Figure 7-8

Load/Speed Relations

uni Flex ONE K750 (Permissible Curve Load)

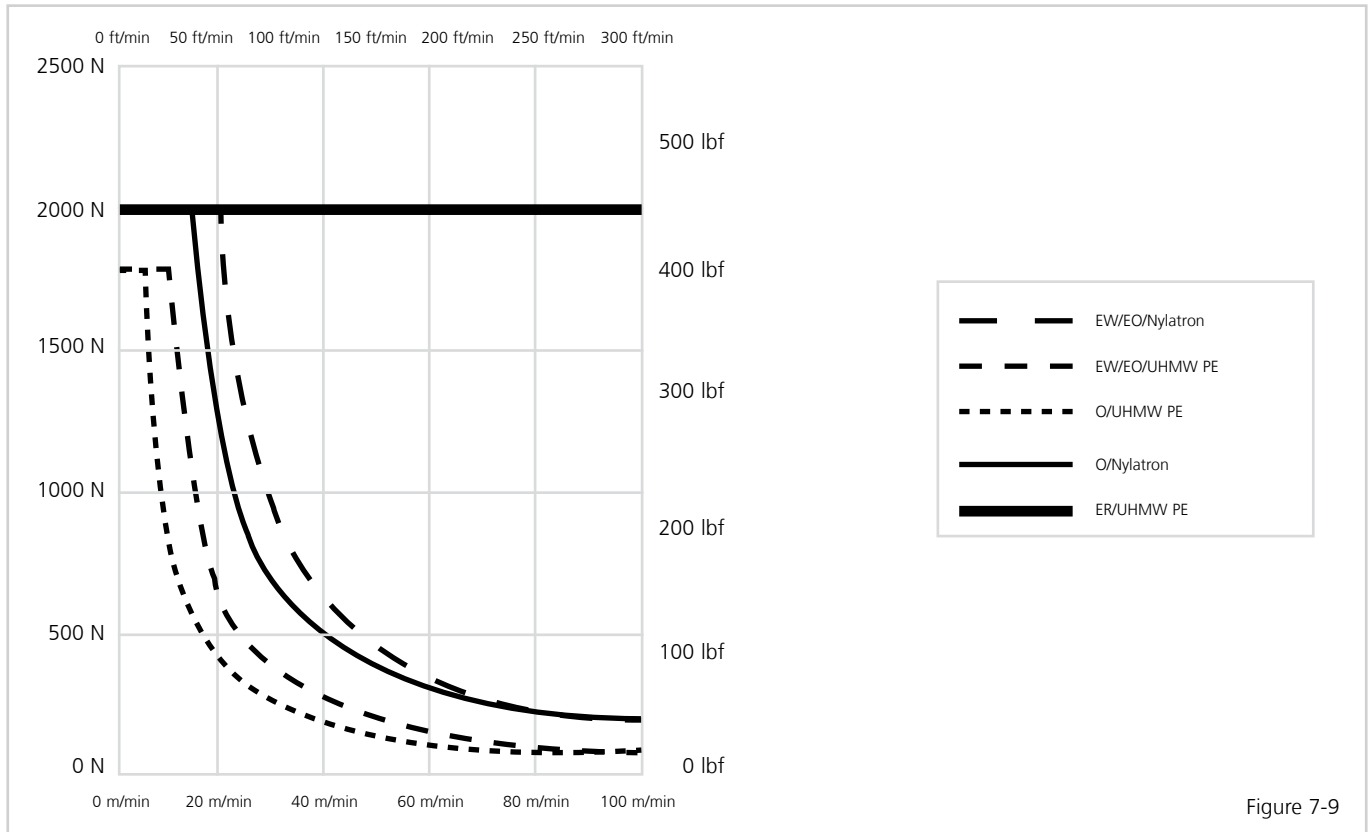

Figure 7-9

uni Flex ONE K1200 (Permissible Curve Load)

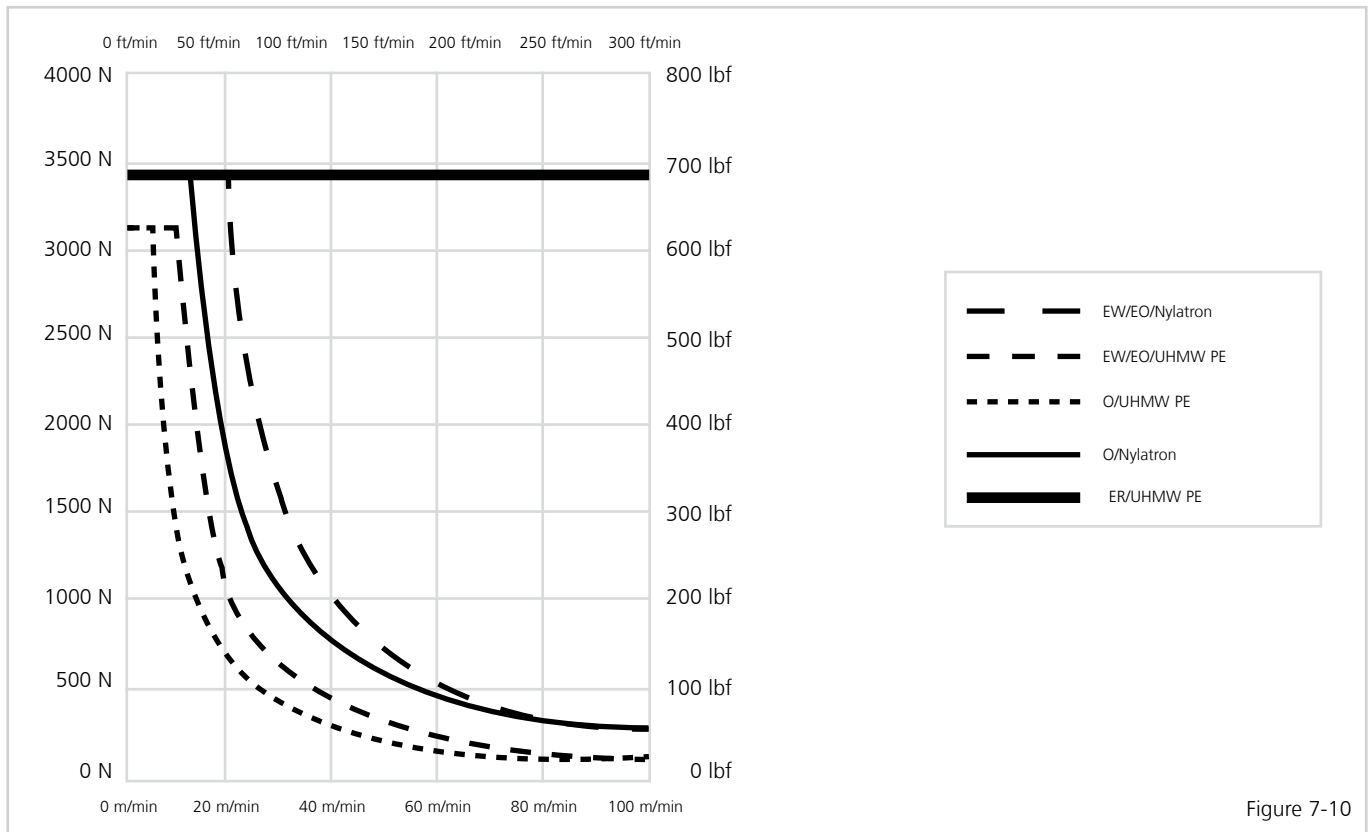

Figure 7-10

Load/Speed Relations

uni Flex ONE K1500 (Permissible Curve Load)

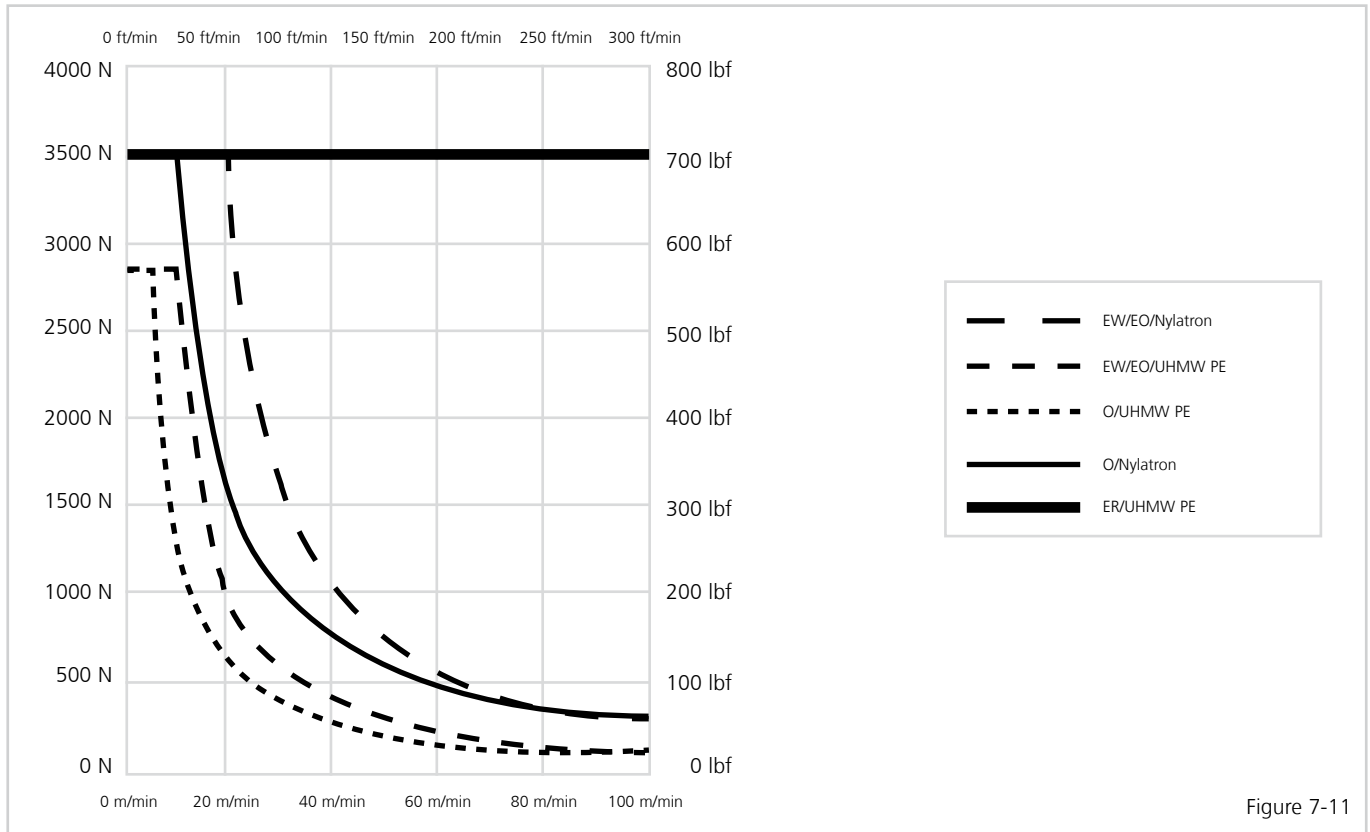

Figure 7-11

uni Flex ONE K2400 (Permissible Curve Load)

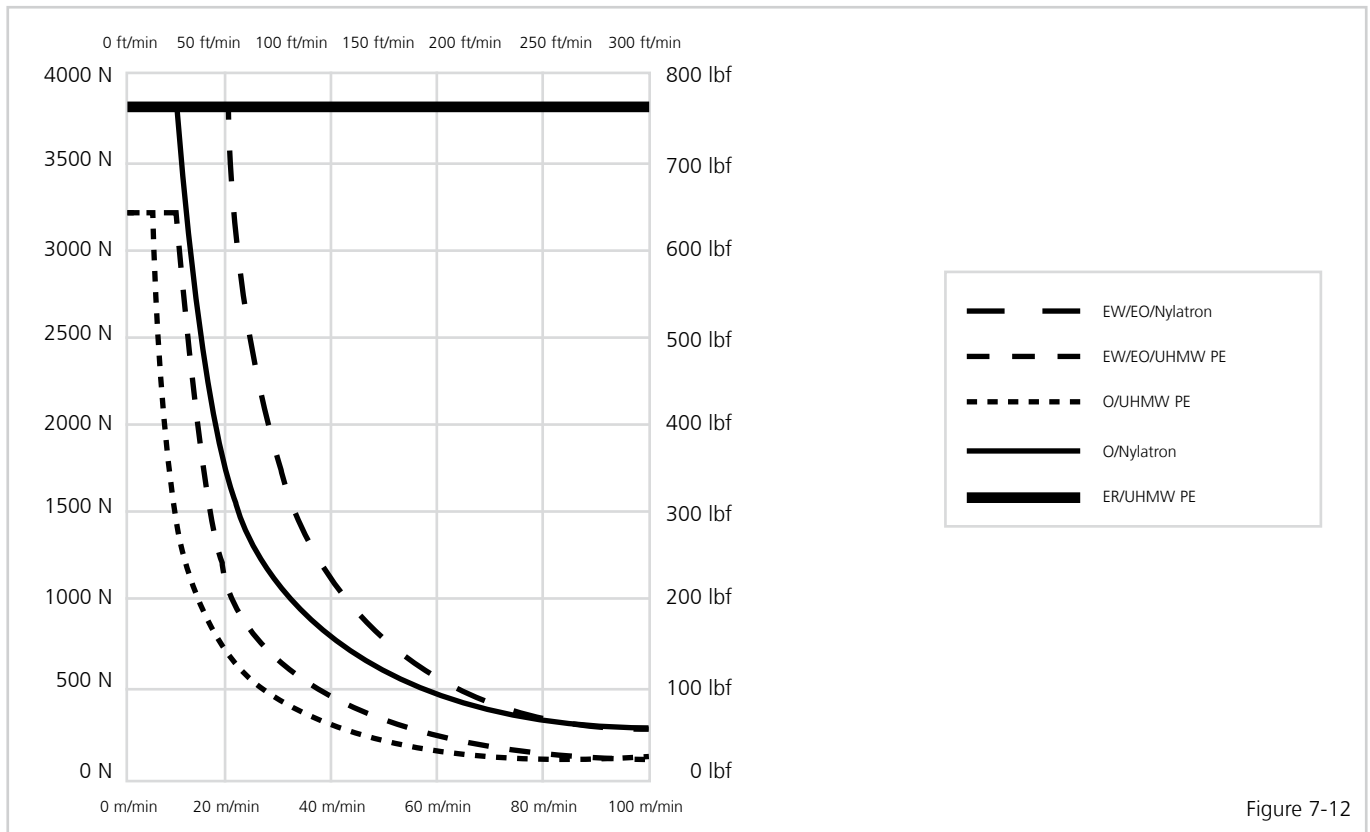

Figure 7-12

Temperature Factors

Temperature Factor - Acetal (POM)

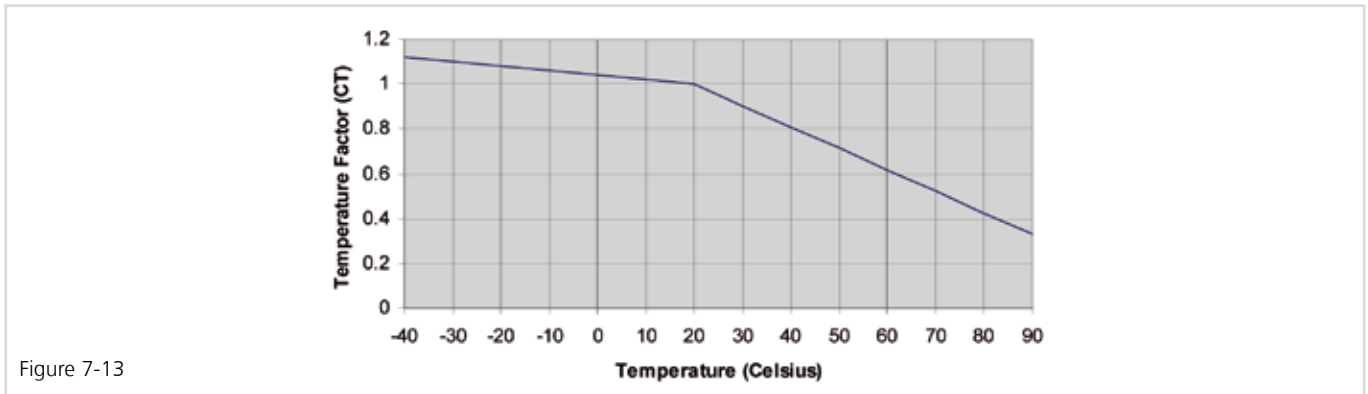

Figure 7-13

Temperature Factor - PP (Polypropylene)

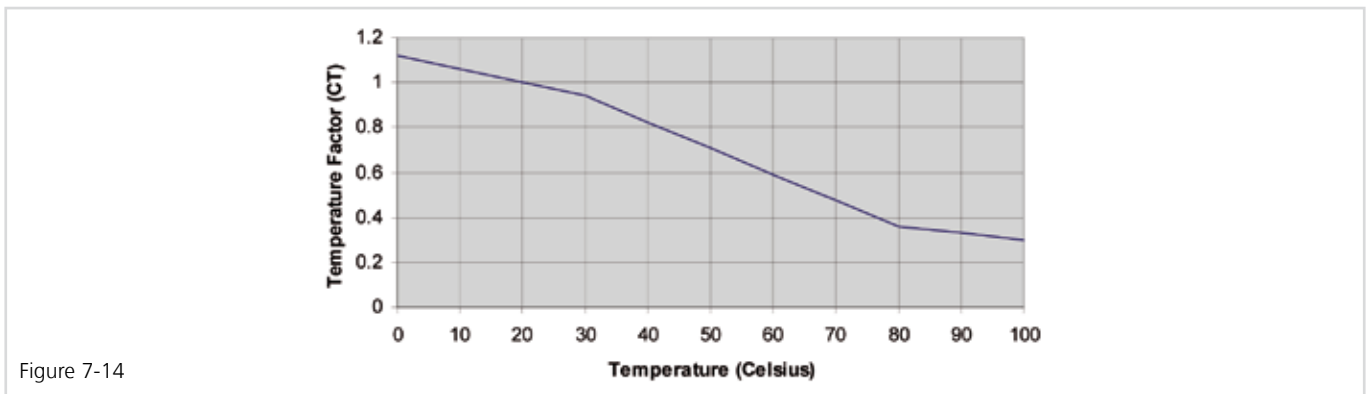

Figure 7-14

Temperature Factor - PE (Polyethylene)

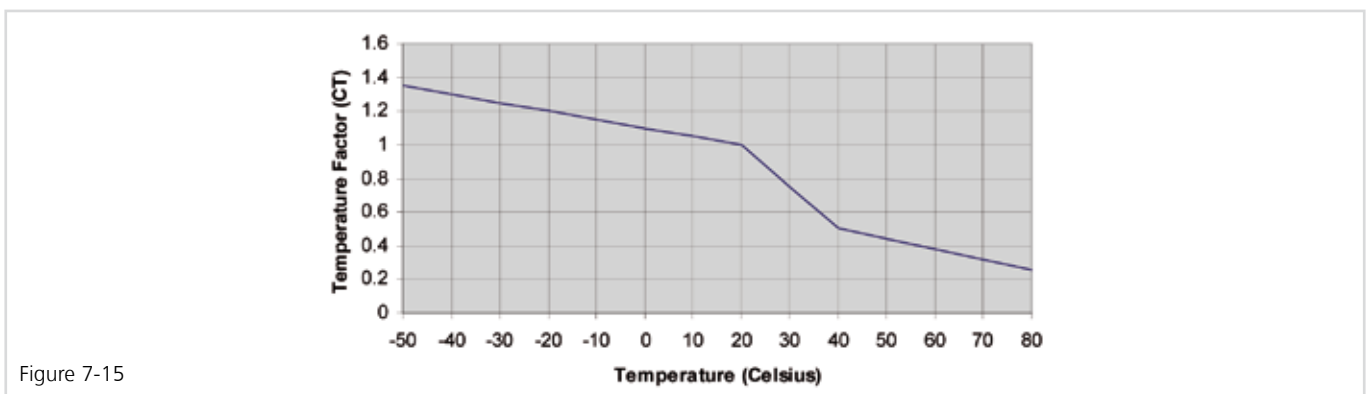

Figure 7-15

Temperature Factor - PA6.6 (Polyamide)

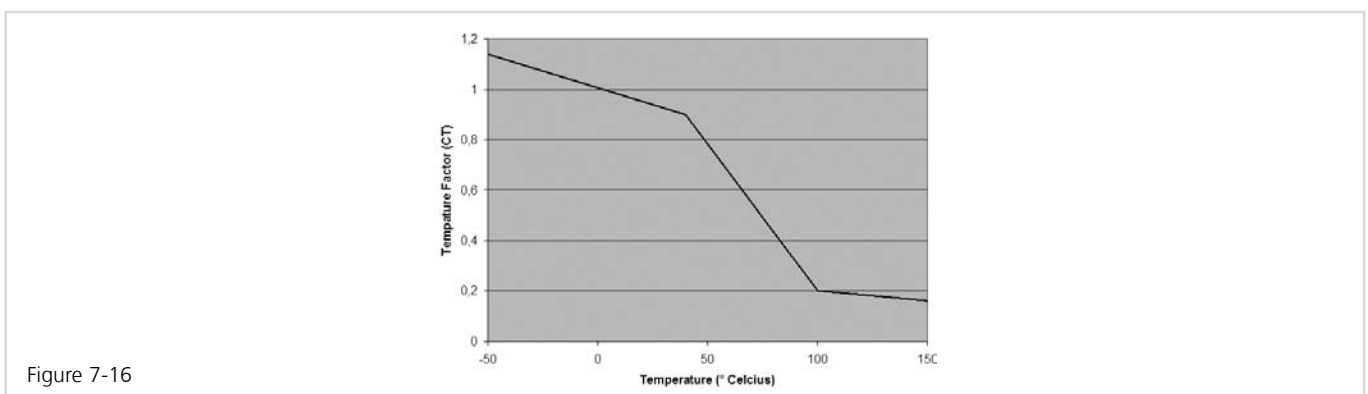

Figure 7-16

Belt Elasticity

The elasticity index values on the table below show a comparison of the relative elasticity of the various belt and pin combinations both dry and wet. The value of

1 is assigned to the uni-chains belt series/material/pin combination that has the most stiffness. All other values are related to this value for a means of comparison.

| Series | Opening | Material | Pin Material | Elasticity Index (dry) | Elasticity Index (wet) |
|-----------|---------|----------|--------------|------------------------|------------------------|
| uni M-QNB | Closed | POM-EC | PA6.6 | 0.30 | 0.30 |
| uni M-QNB | Closed | PE | PA6.6 | 0.15 | 0.15 |
| uni M-QNB | Closed | PP | PA6.6 | 0.17 | 0.18 |
| uni M-QNB | Vacuum | PP | PA6.6 | 0.17 | 0.17 |
| uni M-QNB | Closed | POM-SLF | PA6.6 | 0.31 | 0.31 |
| uni QNB | Closed | PP | PA6.6 | 0.25 | 0.24 |
| uni QNB | Closed | PP | PA6.6 | 0.25 | 0.24 |
| uni QNB | Closed | POM-SLF | PA6.6 | 0.43 | 0.41 |
| uni QNB | Closed | POM-SLF | PA6.6 | 0.43 | 0.41 |
| uni SSB | Closed | POM-LF | GR | 0.29 | |
| uni SSB | Closed | PP | GR | 0.17 | |
| uni SSB | 29% | POM-LF | GR | 0.28 | |
| uni SSB | 29% | PP | GR | 0.16 | |
| uni SSB | 32% | POM-LF | GR | 0.26 | |
| uni SSB | 32% | PP | GR | 0.15 | |
| uni MPB | PRR-16% | POM-DI | PP | 0.19 | |
| uni MPB | Closed | POM-DI | PP | 0.27 | |
| uni MPB | 18% | POM-DI | PP | 0.23 | |
| uni MPB | RO22% | POM-DI | PA6.6 | 0.14 | 0.12 |
| uni MPB | G | POM-DI | PP | 0.29 | |
| uni MPB | Closed | PE-I | PP | 0.11 | |
| uni MPB | 18% | PE-I | PP | 0.07 | |
| uni MPB | 20% | PE-I | PP | 0.08 | |
| uni MPB | 22% | PE-I | PP | 0.08 | |
| uni MPB | N | PE-I | PP | 0.10 | |
| uni MPB | Closed | PP | PP | 0.21 | |
| uni MPB | 18% | PP | PP | 0.13 | |
| uni MPB | 20% | PP | PP | 0.13 | |
| uni MPB | 22% | PP | PP | 0.16 | |
| uni CNB | Closed | POM-D | PA6.6 | 0.19 | 0.17 |
| uni CNB | 22% | POM-D | PA6.6 | 0.12 | 0.11 |
| uni CNB | Closed | PE | PA6.6 | 0.08 | 0.08 |
| uni CNB | 22% | PE | PA6.6 | 0.05 | 0.05 |
| uni CNB | Closed | PP | PA6.6 | 0.11 | 0.11 |
| uni CNB | 18% | PP | PA6.6 | 0.07 | 0.07 |
| uni CNB | 22% | PP | PA6.6 | 0.07 | 0.07 |

Belt Elasticity

| Series | Opening | Material | Pin Material | Elasticity Index (dry) | Elasticity Index (wet) |
|--------------|-------------|----------|--------------|------------------------|------------------------|
| uni L-SNB | 36% | POM-LF | PP | 0.36 | |
| uni L-SNB | 36% | PP | PP | 0.19 | |
| uni L-SNB | Rib36% | PP | PP | 0.23 | |
| uni M-SNB | M3 | POM-D | PA6.6 | 0.30 | 0.34 |
| uni M-SNB M3 | POM-LF | PA6.6 | 0.31 | 0.35 | |
| uni M-SNB M3 | PE | PA6.6 | 0.14 | 0.16 | |
| uni OPB 4V | 36% | PP | PP | 0.19 | |
| uni OPB 4V | 23% Rib | PP | PP | 0.23 | |
| uni OPB 4V | Closed | PP-HW | PP | 0.26 | |
| uni OPB 4V | 23% | PP-HW | PP | 0.21 | |
| uni OPB 4V | 23% Fine | PP-HW | PP | 0.24 | |
| uni Light EP | 22% Fine | PP-HW | PP | 0.19 | |
| uni Light | Closed | POM-LF | PA6.6 | 0.40 | |
| uni Light | 10% | POM-LF | PA6.6 | 0.38 | 0.33 |
| uni Light | 22% | POM-LF | PA6.6 | 0.36 | 0.30 |
| uni Light | Closed | PA6 | GR | 0.25 | 0.00 |
| uni Light | Closed | PP | PA6.6 | 0.30 | 0.26 |
| uni Light | Closed | PP | PA6.6 | 0.24 | 0.23 |
| uni Light | Closed | PP | PA6.6 | 0.25 | 0.24 |
| uni Light | 22% | PP | PA6.6 | 0.23 | 0.20 |
| uni XLB | Closed | POM-NL | PA6.6 | 1.00 | |
| uni XLB | Closed | POM-NLAS | PA6.6 | 0.96 | |
| uni XLB | 15% | POM-NLAS | PA6.6 | 0.95 | |
| uni CPB | Closed | POM-NL | PA6.6 | 0.55 | |
| uni CPB | 20% | POM-NL | PA6.6 | 0.59 | |
| uni CPB | Closed | POM-NLAS | PA6.6 | 0.52 | |
| uni CPB | 20% | POM-NLAS | PA6.6 | 0.53 | |
| uni CPB | Closed | PP | PA6.6 | 0.30 | |
| uni SNB-M2 | 20% | POM-D | PA6.6 | 0.57 | 0.51 |
| uni SNB-M2 | 34% | POM-D | PA6.6 | 0.41 | 0.38 |
| uni SNB-M2 | TAB 34% SLO | POM-D | PA6.6 | 0.45 | 0.43 |
| uni SNB-M2 | 20% | PE | PA6.6 | 0.24 | 0.28 |
| uni SNB-M2 | 34% | PE | PA6.6 | 0.16 | 0.19 |
| uni SNB-M2 | 20% | PP | PA6.6 | 0.31 | 0.30 |
| uni SNB-M2 | 20% RUB R03 | PP | PA6.6 | 0.37 | 0.36 |
| uni SNB-M2 | 34% | PP | PA6.6 | 0.24 | 0.25 |
| uni SNB-M2 | TAB 34% SLO | PP | PA6.6 | 0.28 | 0.31 |
| uni SNB-M2 | 34%'Rib | PP | PA6.6 | 0.25 | 0.26 |
| uni SNB-M2 | 34%'Rib | POM-SLF | PA6.6 | 0.45 | 0.45 |
| uni S-MPB | Closed | POM-DI | PA6.6 | 0.24 | 0.21 |

Belt Elasticity

| Series | Opening | Material | Pin Material | Elasticity Index (dry) | Elasticity Index (wet) |
|-----------|---------|----------|--------------|------------------------|------------------------|
| uni S-MPB | Closed | PE-I | PA6.6 | 0.09 | 0.10 |
| uni S-MPB | Closed | PP | PA6.6 | 0.14 | 0.14 |
| uni X-MPB | Closed | POM-DI | PA6.6 | 0.27 | 0.21 |
| uni X-MPB | Closed | PE-I | PA6.6 | 0.09 | 0.08 |
| uni X-MPB | Closed | PE-I | PA6.6 | 0.08 | 0.08 |

Glossary

| Term | Explanation |
|---|--|
| Accumulation conveyors | Conveyors that collect temporary product overflows |
| Accumulation length (distance) | Distance of product accumulation in running direction of the belt |
| Adjusted tensile force (adjusted belt pull) per meter of belt width | Applies a service factor to adjust the effective tensile force calculated near the driving sprocket, taking into account eventual inclines and frequent starts/stops |
| Admissible tensile force per meter of belt width | Force or belt pull per meter of belt width allowed near the driving sprocket under process conditions (temperature, speed) |
| Transport length | Conveying length measured between the centers of driving and idling shafts |
| Backflex (Backbend) | Negative bending of the belt (opposite of belt bending over sprocket) |
| Belt length, inclined | Conveying length measured as vertical projection of distance between the centers of driving and idling shafts |
| Belt length, theoretical | Length of belt measured around the sprockets including excessive length of catenary sag |

Glossary

| Term | Explanation |
|---------------------------|--|
| Belt pitch (module pitch) | Center distance between the pivot rods (hinge rods) of a belt module |
| Belt width | Geometrical width of assembled belt from edge to edge |
| Bi-directional drive | Driving concept allowing to run the belt forward and backward |
| Bricklaid | Modules of the assembled belts are staggered from row to row (like bricks of a brick wall) |
| Carryway | Slider support (belt support) with wear strips or slider bed |
| Catenary sag | Unsupported length of the belt for absorbing belt length variations due to thermal expansion and load changes of belt |
| Center driven belt | Sprocket of the belt engaging in the middle of the modules |
| Central drive concept | Motor located on the lower belt track halfway in between the belt ends (for bi-directional drive) |
| Chevron supports | Belt supports with wear strips arranged in an overlapping "V-pattern" |
| Chordal action | Polygon effect: Pulsation of the belt velocity caused by the polygon shape of the driving sprocket, with rise and fall of the belt surface |
| Coefficient of friction | Ratio of frictional force and contact force acting between two material surfaces |

Glossary

| Term | Explanation |
|---|--|
| Coefficient of thermal expansion | Ratio of belt lengthening and the product of belt length and temperature change |
| Dead plate | Metal or plastic plate installed between meeting conveyors as a transfer bridge |
| Effective tensile force (effective belt pull) per meter of belt width | Calculated near the driving sprocket, where it reaches in the most cases its maximum value during operation. It depends on the friction forces between the belt and the slider supports (ST) and (SR) as well as friction against the accumulated load |
| Elevating conveyor | Conveyors transporting the products to a higher or lower level, using flights or other suitable means to keep the products in place |
| EU | Material is compliant for food contact articles in at least one member state of the European Union |
| FDA | Food and drug administration. Federal Agency of the US which regulates materials that may come in contact with food |
| Finger plates (Combs) | Transfer plates, installed at the belt ends of the raised rib belt. Their fingers extend between the ribs of the belt for smooth transfer of the product |
| Flat Top belt | Flat top belt with 0% open area and a variety of reverse sides |
| Flat Top belt, perforated | The same as flat top belt solid, but its plate-modules are providing slots or holes for draining fluids |
| Flight | Belt module with molded vertical plate for elevating conveyors. The flights prevent the product from slipping back while being moved upwards |
| Flush Grid belt | Belt with large percentage of open area, usually over 20%. Particularly suitable for washing, cooling applications or if dust/dirt is falling off the product |

Glossary

| Term | Explanation |
|--|--|
| Gravity take-up | Belt is tensioned by the weight of a roller resting on the belt at the catenary sag on its return way (for long belts mainly) |
| Hinge driven belts | Sprocket engages at the hinge of the belt |
| Hold down device | Module for straight running belts with T-shaped tab on the belt bottom, running in special guiding rails. Main application for large Z-conveyors to keep the belt on the base when changing from horizontal to inclined run |
| Hold down tab (hook modules) | "Hook" shaped tabs on the bottom of the radius belt edge, running below a guide rail. Prevent the belt from lifting off the base in the curve |
| Idling shafts | Shaft at the belt end opposite of the driving shaft. It is normally equipped with sprockets or alternatively for shorter belts flat drums can be used |
| Indent | Space at belt edge free of flight or rubber lining |
| ISO 340 and EN 20340 | International Standards for flame retardation of conveyor belts. Standardized test specimen is cut out of a belt including rod and modules and will be exposed to a flame for 45 seconds. Standard is fulfilled if the flame is extinct within 15 seconds after the flame is removed |
| Mass of belt per meter squared | The belt mass (weight) is added to the product mass per meter squared for calculation of the friction force between belt and slider frame |
| Mass of product per meter squared (product weight per meter squared) | Conveyed product weight as expected to be distributed over the belt surface; calculated average load per meter squared |
| Nominal tensile strength per meter of belt width | Catalogue value. It reflects the maximum allowable belt pull at room temperature and very low speed |
| Oblong hole | Pivot hole with oblong shape for better cleaning |

Glossary

| Term | Explanation |
|------------------------------|--|
| Open area | Percentage of open surface (real openings in projections, perforation of the belt) |
| Open contact area | Percentage of belt surface which is not in contact with the conveyed product |
| Open hinge | The module hinge is designed in a way, that the pivot rod (hinge rod) is exposed to a part of its surface allowing better cleaning |
| Perforated Flat Top | See Flat Top perforated |
| Pitch | The distance from pin to pin in chain or belting |
| Pitch diameter | Diameter of the sprocket which defines the position of the pivot rods of the driven belt |
| Pivot pins (Connecting Pins) | These pins link the modules of the belt together to provide pivoting and strong connection. Materials are normally PP, and PE and PA6.6 |
| Polygon effect | "Chordal action": Pulsation of the belt velocity caused by the polygon shape of the driving sprocket, with rise and fall of the belt surface |
| Product Support | A plastic insert for belting and chain. Product supports can increase the angle of inclined conveyors by supporting the product |
| PV Limits | PV Limits is the relationship between load and speed |
| Radius belt | Belt suitable for running around curves (radius applications) with a minimum inside radius of 2.2 times the belt width |

Glossary

| Term | Explanation |
|--------------------|---|
| Raised Rib belt | Belt with higher longitudinal ribs on its top surface. These ribs create longitudinal "slots" for the engagement of finger plates for smooth product transfer at the belt end. |
| Screw type take-up | The catenary sag is adjusted by means of a screw tensioning device at the idling shaft of the conveyor |
| Service factor | The calculated effective belt pull is adjusted with the service factor taking into account eventual heavy running conditions (start/stop, inclination) |
| Side guards | Plates designed to be installed lengthwise at the belt edge to form a wall. Usually used in connection with Flights |
| Slider support/bed | Frame equipped with wear strips to carry the running belt with low friction and wear. A closed plate is called a slider bed |
| Speed factor | The nominal tensile force, valid at very low speed and room temperature, is reduced to the permissible tensile force by the influence of higher speed and/or temperature; therefore it is multiplied with the respective factor |
| Spiral conveyor | Radius belt with more than 1 full turn, travelling in a helical path around a central cylinder upwards or downwards |
| Sprocket | Gear, mostly plastic or exceptionally from metal, shaped to engage in the grid pattern of the belt modules, providing positive torque transmission to the belt |
| Take-up | Tensioning device for adjustment of the catenary sag, screw type, gravity type or spring loaded type at the idling shaft of the conveyor |
| Temperature factor | The nominal tensile force, valid at very low speed and room temperature, is reduced to the admissible tensile force by the influence of higher speed and/or temperature; therefore it is multiplied with the respective factor |
| USDA | United States Department of Agriculture. US federal agency which has defined requirements for equipment which may be in contact with meat, dairy and poultry |
| Wearstrip | Plastic strip, mainly from PE, used on the support frame of the belt to provide low friction and low wear |

Chemical Resistance Chart

| Chemical | Temperature °C | Concentration % | PP | PE | POM | PA | PET/PBT | PC | GR | PP + GF | PA + GF | PVDF | PSU | TEFLON | TPE |
|--------------------------------------|----------------|-----------------|----------|----|-----|----|---------|----|----|---------|---------|------|-----|--------|-----|
| | | | A | | | | | | | | | | | | |
| POMdehyde Aq. | 20 | 40 | R | R | R | S | R | Q | | | | R | Q | | |
| POMdehyde Aq. | 60 | | S | | | | | NR | | | | | | | |
| POMyde | 20 | 40 | | S | R | | | | | | | | | | |
| POMyde | 20 | 100 | | S | S | | | | | | | | | | |
| Acetamide Soln. | 20 | 50 | | | R | S | | | | | | | | | |
| Acetate Solv | 20 | | NR | | | S | | | | | | | | | |
| Acethyl Chloride | 20 | | | | Q | Q | | | | | | | | | |
| Acetic Acid Aq. | 20 | 5 | R | R | R | S | R | R | | | | | | | |
| Acetic Acid Aq. | 60 | 5 | R | R | R | Q | | | | | | | | | |
| Acetic Acid Aq. | 20 | 10 | R | R | R | S | R | R | | | | | | | |
| Acetic Acid Aq. | 60 | 10 | R | R | S | Q | R | S | | | | | | | |
| Acetic Acid Aq. | 20 | 20 | R | R | Q | Q | R | R | | | | | | | |
| Acetic Acid Aq. | 60 | 20 | R | R | Q | Q | S | S | | | | | | | |
| Acetic Acid Aq. | 20 | 95 | S | S | NR | NR | Q | S | | | | | | | |
| Acetic Acid Aq. | 60 | 95 | S | Q | NR | NR | Q | S | | | | | | | |
| Acetic anhydride | 20 | 100 | R | | NR | NR | | | | | | | | | |
| Acetic anhydride | 60 | 100 | R | | | | | | | | | | | | |
| Acetone | 20 | 100 | R | S | R | R | S | Q | | | | | Q | | R |
| Acetone | 60 | 100 | S | Q | S | R | NR | NR | | | | | | | |
| Acetophenone | 20 | | R | | R | R | R | | | | | | | | |
| Acetyl Chloride | 20 | | | | | NR | | | | | | | | | |
| Acetylene | 20 | | R | | R | R | R | R | | | | | | | |
| Acrylic Acid | 20 | | | | Q | NR | R | | | | | | | | NR |
| Acrylic Emulsions | 20 | | | R | | | | | | | | | | | |
| Acrylic Emulsions | 60 | | | S | | | | | | | | | | | |
| Acrylonitril | 20 | | S | | | | | | | | | | | | |
| Adipic acid | 20 | | | R | | | | | | | | | | | NR |
| Air | 20 | | | | R | R | R | | | | | | | | |
| Alcohols (see Methanol, Ethanol ect) | 20 | | R | R | R | R | | | | | | | | | |
| Alcohols, Aliphatic | 20 | | | | | | | | | | | | | | |
| Alcohols, Amyl | 20 | | S | | R | R | | | | | | | | | |
| Alcohols, Benzyl | 20 | | | | R | | | | | | | | | | |
| Alcohols, Butyl | 20 | | | | R | | | | | | | | | | |
| Alcohols, Diacetone | 20 | | | | R | | | | | | | | | | |
| Alcohols, Ethyl | 20 | | | | R | | | | | | | | | | |
| Alcohols, Hexyl | 20 | | | | R | | | | | | | | | | |
| Alcohols, Isobutyl | 20 | | | | R | | | | | | | | | | |
| Alcohols, Isopropyl | 20 | | | | R | | | | | | | | | | |
| Alcohols, Methyl | 20 | | | | R | | | | | | | | | | |
| Alcohols, Octyl | 20 | | | | R | | | | | | | | | | |
| Alcohols, Propyl | 20 | | | | R | | | | | | | | | | |
| Aliphatic Hydrocarbon Blend | 20 | | | | R | R | R | | | | | | | | |
| Alkylbenzenes (Shellsol A) | 20 | | | | R | R | R | | | | | | | | |
| Allyl alcohol | 20 | 96 | R | R | S | S | R | Q | | | | | S | | |
| Allyl chloride | 20 | | | | | | | | | | | | | | |

- R** = Recommended. No attack, possibly slight absorption. No effect on mechanical properties.
- S** = Suitable. Slight attack by absorption. Some swelling and a small reduction in mechanical properties likely.
- Q** = Questionable. Moderate attack of appreciable absorption. Material will have limited life.
- NR** = Not Recommended. Material will decompose or dissolve in a short time.

Chemical Resistance Chart

| Chemical | Temperature °C | Concentration % | PP | PE | POM | PA | PET/PBT | PC | GR | PP + GF | PA + GF | PVDF | PSU | TEFLON | TPE |
|---|----------------|-----------------|----|----|-----|----|---------|----|----|---------|---------|------|-----|--------|-----|
| | | | | | | | | | | | | | | | |
| Ammonium Salts of minerals | 20 | | | | R | R | R | R | | | | | | | |
| Ammonium Sulphate | 20 | | R | R | S | Q | | Q | | | | | | | |
| Ammonium Sulphate | 60 | | R | R | S | Q | | | | | | | | | |
| Ammonium Sulfide | 20 | | | R | NR | | | | | | | | | | |
| Ammonium Sulfide | 60 | | | R | NR | | | | | | | | | | |
| Ammonium Thiosulfate | 20 | | | | S | | | | | | | | | | |
| Ammonium Thiocyanate | 20 | | | R | R | R | R | | | | | | | | |
| Ammonium Thiocyanate | 60 | | | R | | | | | | | | | | | |
| Amyl Acetate | 20 | | S | Q | R | Q | R | Q | | | | | | | |
| Amyl Acetate | 60 | | Q | Q | S | Q | | | | | | | | | |
| Amyl Alcohol | 20 | | R | R | R | R | R | | | | | | | | |
| Amyl Alcohol | 60 | | R | R | R | R | | | | | | | | | |
| Amyl Chloride | 20 | 100 | NR | S | R | Q | | NR | | | | | | | |
| Amyl Chloride | 60 | 100 | NR | Q | R | Q | | NR | | | | | | | |
| Aniline | 20 | | S | R | R | Q | | | | | | | | | |
| Aniline Hydrochloride | 20 | | R | Q | | | | | | | | | | | |
| Aniline Sulphate | 20 | | | Q | | | | | | | | | | | |
| Aniline | 20 | 100 | R | R | S | S | S | Q | | | | | Q | R | |
| Aniline | 60 | 100 | | Q | | Q | | NR | | | | | | | |
| Animal Oils | 20 | | | S | | | | | | | | | | | |
| Antimony Chloride | 20 | | | R | | | | | | | | | | | |
| Antimony Chloride | 60 | | | R | | | | | | | | | | | |
| Antimony Pentachloride | 20 | | | R | | | | | | | | | | | |
| Antimony Trichloride | 20 | | R | | | | | | | | | | | | |
| Anodizing Baths (30% nitric acid 10% sulfuric acid) | 20 | | | | Q | S | S | | | | | | | | |
| Anthraquinone | 20 | | | | R | S | | | | | | | | | |
| Antifreeze (see Coolants) | 20 | | | | NR | | | | | | | | | | |
| Antimony Trichloride Aq. | 20 | | | | Q | Q | | R | | | | | | | |
| Aqua Regia (HCL/HNO3) | 20 | | Q | Q | Q | Q | Q | | | | | | | | |
| Aqua Regia (HCL/HNO3) | 60 | | Q | NR | NR | | | | | | | | | | |
| Arcton | 20 | | | S | | | | | | | | | | | |
| Argon | 20 | | | | R | R | R | | | | | | | | |
| Aromatic Hydrocarbon Blend | 20 | | | | R | R | S | | | | | | | | |
| Arcenic Acid | 20 | | R | R | Q | R | Q | | | | | | | | |
| Asphalt | 20 | | R | | S | R | R | | | | | | | | |
| B | | | | | | | | | | | | | | | |
| 1-Butene, cis-2-butene (Liquefied gas DIN 51622) | 20 | | | | R | R | R | | | | | | | | |
| Bacteria (DIN 53739) | 20 | | | | R | R | R | | | | | | | | |
| Baking Enamels | 20 | | | | S | R | R | | | | | | | | |
| Barium Carbonate | 20 | | R | R | R | R | | | | | | | | | |
| Barium Carbonate | 60 | | R | R | R | R | | | | | | | | | |
| Barium Chloride Aq. | 20 | | R | R | R | Q | | | | | | | | | |
| Barium Chloride Aq. | 60 | | R | R | R | Q | | | | | | | | | |
| Barium compounds | 20 | | R | R | | | | | | | | | | | |
| Barium compounds | 60 | | | | | | | | | | | | | | |
| Barium Cyanide | 20 | | | | S | | | | | | | | | | |
| Barium Hydroxide | 20 | | R | R | NR | R | | | | | | | | | |
| Barium Hydroxide | 60 | | R | R | NR | R | | | | | | | | | |
| Barium Nitrate | 20 | | | | S | | | | | | | | | | |
| Barium Sulphate Aq. | 20 | | R | R | S | R | | | | | | | | | |
| Barium Sulphate Aq. | 60 | | R | R | S | R | | | | | | | | | |
| Barium Sulphide | 20 | | R | R | R | S | | | | | | | | | |
| Barium Sulphide | 60 | | R | R | R | S | | | | | | | | | |
| Beef Suet | 20 | | | | | R | | | | | | | | | |
| Beer | 20 | | S | R | R | R | R | R | | | | | | | |

Chemical Resistance Chart

| Chemical | Temperature °C | Concentration % | PP | PE | POM | PA | PET/PBT | PC | GR | PP + GF | PA + GF | PVDF | PSU | TEFLON | TPE |
|---|----------------|-----------------|----|----|-----|----|---------|----|----|---------|---------|------|-----|--------|-----|
| | | | | | | | | | | | | | | | |
| Disinfection by irradiation (25 kGy for 6 h) | 20 | | | | S | R | R | | | | | | | | |
| Disodium Phosphate | 20 | | | R | | | | | | | | | | | |
| Disodium Phosphate | 60 | | | R | | | | | | | | | | | |
| Diisopropyl Ether | 20 | | | | | | | | | | | | | | |
| Dispersions, Aqueous (BASF Acronal, Propifan) | 20 | | | | R | R | R | | | | | | | | |
| E | | | | | | | | | | | | | | | |
| Edible Oils | 20 | | | | R | R | R | R | | | | | | | |
| Electroplating baths, acidic | 20 | | | | Q | Q | R | | | | | | | | |
| Electroplating baths, alkali (Cyanides) | 20 | | | | R | R | S | | | | | | | | |
| Emulsifiers | 20 | | | R | | | | | | | | | | | |
| Emulsions, Photographic | 20 | | | R | | | | | | | | | | | |
| Emulsions, Photographic | 60 | | | R | | | | | | | | | | | |
| Engine oils (see Lubricating Oils) | 20 | | | | | R | | | | | | | | | |
| Epichlorhydrin | 20 | | | | | S | | | | | | | | | |
| Epsom Salts | 20 | | R | | S | | | | | | | | | | |
| Ethane | 20 | | | | R | R | R | | | | | | | | |
| Ethanol | 20 | | R | | R | R | R | R | | | | | | | S |
| Ethanol | 60 | | | | | | R | | | | | | | | |
| Ethanolamine | 20 | | | | NR | | | | | | | | | | |
| Ethanoic Acid | 20 | 10 | R | R | | Q | | | | | | | | | R |
| Ether, Diethyl | 20 | | | Q | R | Q | | | | | | | | | |
| Ethereal oil | 20 | | | | R | R | R | | | | | | | | |
| Ethyl | 20 | | R | | | R | | | | | | | | | |
| Ethyl Acetate | 20 | 100 | S | S | R | R | Q | NR | | | | | | | Q |
| Ethyl Acetate | 60 | 100 | Q | NR | R | | NR | NR | | | | | | | |
| Ethyl Alcohol | 20 | 35 | | R | | S | | | | | | | | | |
| Ethyl Alcohol | 60 | 35 | | R | | Q | | | | | | | | | |
| Ethyl Alcohol | 20 | 100 | R | R | | S | | R | | | | | | | |
| Ethyl Alcohol | 60 | 100 | | R | | NR | | S | | | | | | | |
| Ethyl Butyrate | 20 | | | S | | | | | | | | | | | |
| Ethyl Butyrate | 60 | | | Q | | | | | | | | | | | |
| Ethyl Chloride | 20 | | S | Q | R | R | | NR | | | | | | | |
| Ethyl Chloride | 60 | | Q | NR | R | | | NR | | | | | | | |
| Ethyl Dichloride | 20 | 100 | S | Q | | | | NR | | | | | | | |
| Ethyl Dichloride | 60 | | | | | | | NR | | | | | | | |
| Ethyl Ether | 20 | | NR | NR | R | R | R | NR | | | | | | | |
| Ethyl Ether | 60 | | NR | NR | R | | | NR | | | | | | | |
| Ethyl Formate | 20 | | | | | | | | | | | | | | |
| Ethylene | 20 | | | | R | R | R | | | | | | | | |
| Ethylene Carbonate | 20 | | | | | R | Q | | | | | | | | |
| Ethylene Chloride | 20 | | S | Q | S | R | | Q | | | | | | | |
| Ethylene Chloride | 60 | | Q | NR | S | | | NR | | | | | | | |
| Ethylene Chlorohydrin | 20 | | | Q | NR | S | Q | | | | | | | | |
| Ethylene Chlorohydrin | 60 | | | NR | | | | | | | | | | | |
| Ethylene Dichloride (see Ethylene Chloride) | 20 | | S | Q | S | R | | Q | | | | | | | |
| Ethylene Dichloride (see Ethylene Chloride) | 60 | | Q | NR | S | | | NR | | | | | | | |
| Ethylene Diamine | 20 | | | | NR | | | | | | | | | | |
| Ethylene Glycol Aq. | 20 | | R | R | R | S | R | R | | | | | | | R |
| Ethylene Glycol Aq. | 60 | | R | R | S | S | NR | | | | | | | | |
| Ethylene Oxide | 20 | | Q | Q | Q | R | R | Q | | | | | | | |
| Ethylene Oxide | 60 | | | | NR | | | NR | | | | | | | |
| Ethylenediamine | 20 | | | | | R | | | | | | | | | |
| Exhaust fumes from Internal combustion engine | 20 | | | | R | R | R | | | | | | | | |
| F | | | | | | | | | | | | | | | |

Chemical Resistance Chart

| Chemical | Temperature °C | Concentration % | PP | PE | POM | PA | PET/PBT | PC | GR | PP + GF | PA + GF | PVDF | PSU | TEFLON | TPE |
|--|----------------|-----------------|----|----|-----|----|---------|----|----|---------|---------|------|-----|--------|-----|
| | | | | | | | | | | | | | | | |
| Oils: Clove | 20 | | S | | | | | | | | | | | | |
| Oils: Coconut | 20 | | R | | R | | | | | | | | | | |
| Oils: Cod Liver | 20 | | R | | R | | | | | | | | | | |
| Oils: Corn | 20 | | R | | R | | | | | | | | | | |
| Oils: Cotton Seed | 20 | | R | | | | | | | | | | | | |
| Oils: Creosote | 20 | | NR | | NR | | | | | | | | | | |
| Oils: Diesel Fuel (2D,3D,4D,5D) | 20 | | R | | NR | | | | | | | | | | |
| Oils: Fuel (1,2,3,5A,5B,6) | 20 | | S | | NR | | | | | | | | | | |
| Oils: Ginger | 20 | | | | R | | | | | | | | | | |
| Oils: Hydraulic Oil (Petro) | 20 | | | | R | | | | | | | | | | |
| Oils: Hydraulic Oil (Synthetic) | 20 | | | | | | | | | | | | | | |
| Oils: Lemon | 20 | | NR | | NR | | | | | | | | | | |
| Oils: Linseed | 20 | | R | | R | | | | | | | | | | |
| Oils: Mineral | 20 | | S | | R | | | | | | | | | | |
| Oils: Olive | 20 | | R | | R | | R | | | | | | | | |
| Oils: Olive | 60 | | | | | | R | | | | | | | | |
| Oils: Orange | 20 | | R | | NR | | | | | | | | | | |
| Oils: Palm | 20 | | | | R | | | | | | | | | | |
| Oils: Paraffin | 20 | | | | | | R | | | | | | | | |
| Oils: Paraffin | 60 | | | | | | R | | | | | | | | |
| Oils: Peanut | 20 | | Q | | R | | | | | | | | | | |
| Oils: Peppermint | 20 | | Q | | NR | | | | | | | | | | |
| Oils: Pine | 20 | | | | R | | | | | | | | | | |
| Oils: Rapseed | 20 | | | | R | | | | | | | | | | |
| Oils: Rosin | 20 | | R | | | | | | | | | | | | |
| Oils: Sesame Seed | 20 | | | | NR | | | | | | | | | | |
| Oils: Silicone | 20 | | R | | R | | | | | | | | | | |
| Oils: Soybean | 20 | | R | | R | | | | | | | | | | |
| Oils: Sperm (whale) | 20 | | | | NR | | | | | | | | | | |
| Oils: Tanning | 20 | | | | NR | | | | | | | | | | |
| Oils: Transformer | 20 | | | | S | | | | | | | | | | |
| Oils: Turbine | 20 | | | | R | | | | | | | | | | |
| Oils: | 20 | | | | | | | | | | | | | | |
| Oleic Acid | 20 | | S | R | R | R | R | | | | | | | | |
| Oleic Acid | 60 | | | Q | | | | | | | | | | | |
| Oleum | 20 | 25 | Q | Q | Q | NR | Q | | | | | | | | |
| Oleum | 60 | 25 | NR | Q | NR | NR | | | | | | | | | |
| Oleum | 20 | 100 | | NR | NR | NR | | | | | | | | | |
| Oleum | 60 | 100 | | NR | NR | NR | | | | | | | | | |
| Olive | 20 | | | | | | R | | | | | | | | |
| Orange | 20 | | | R | | R | | | | | | | | | |
| Oxalic Acid | 20 | 10 | R | R | S | Q | R | R | | | | | | R | |
| Oxalic Acid | 60 | 10 | R | R | Q | NR | | | | | | | | | |
| Oxygen | 20 | | R | | R | S | R | | | | | | | | |
| Ozone | 20 | 100 | Q | Q | Q | Q | Q | R | | | | | | R | |
| Ozone | 60 | 100 | | NR | | | | | | | | | | | |
| Ozone (1 ppm in water) | 20 | | R | R | R | R | R | | | | | | | | |
| Ozone (20 ppm in air) | 20 | | S | S | S | Q | R | | | | | | | | |
| P | | | | | | | | | | | | | | | |
| Iso Propyl Alcohol | 20 | | | | | | | | | | | | | | |
| Paint Solvents | 20 | | | | R | R | S | | | | | | | | |
| Palamoll, Palatinol grades (BASF) | 20 | | | | R | R | R | | | | | | | | |
| Palatal resin(BASF) (see Polyester resins) | 20 | | | | | | | | | | | | | | |
| Palmitic Acid | 20 | | S | R | R | R | R | | | | | | | | |
| Paraffin Oil | 20 | | R | | R | R | R | R | | | | | | | |

Chemical Resistance Chart

| Chemical | Temperature °C | Concentration % | PP | PE | POM | PA | PET/PBT | PC | GR | PP + GF | PA + GF | PVDF | PSU | TEFLON | TPE |
|---|----------------|-----------------|----|----|-----|----|---------|----|----|---------|---------|------|-----|--------|-----|
| Paraffin Oil | 60 | | | | | | R | | | | | | | | |
| Pentane | 20 | | | | | S | R | | | | | | | | |
| Peracetic acid | 20 | | | | | Q | Q | | | | | | | | |
| Perchloric Acid Aq. | 20 | 10 | R | R | Q | NR | NR | NR | | | | | | | |
| Perchloric Acid Aq. | 60 | 10 | R | R | NR | NR | NR | NR | | | | | | | |
| Perchloric Acid Aq. | 20 | 70 | R | R | NR | NR | NR | NR | | | | | | | |
| Perchloric Acid Aq. | 60 | 70 | S | S | NR | NR | NR | NR | | | | | | | |
| Perchloroethylene (see Tetrachloroethylene) | 20 | | NR | | R | R | Q | | | | | | | | |
| Perchloroethylene (see Tetrachloroethylene) | 60 | | NR | | | | NR | | | | | | | | |
| Perfume (alcoholic) | 20 | | | | R | R | R | | | | | | | | |
| Perhydrol (see Hydrogen Peroxide) | 20 | | | | | | | | | | | | | | |
| Petrol, Low-octane | 20 | | | | | | R | | | | | | | | |
| Petrol, Low-octane | 60 | | | | | | R | | | | | | | | |
| Petrol, High-octane | 20 | | | | | | R | | | | | | | | |
| Petrol, High-octane | 60 | | | | | | R | | | | | | | | |
| Petrol, Methanol 85/15 | 20 | | | | | | R | | | | | | | | |
| Petrol, Methanol 85/16 | 60 | | | | | | R | | | | | | | | |
| Petrolatum | 20 | | | | S | | | | | | | | | | |
| Petroleum | 20 | | R | R | S | R | R | Q | | | | | R | | |
| Petroleum ether, Petroleum solvents | 20 | | S | Q | R | R | R | Q | | | | | | | |
| Petroleum ether, Petroleum solvents | 60 | | | NR | | | | NR | | | | | | | |
| Phenol | 20 | 10 | R | Q | Q | NR | NR | S | | | | | | | |
| Phenol | 60 | 10 | S | Q | NR | NR | NR | NR | | | | | | | |
| Phenol (Carbolic Acid) | 20 | 90 | | NR | NR | | | | | | | | | | |
| Phenol (Carbolic Acid) | 60 | 90 | | NR | NR | | | | | | | | | | |
| Phenyl Ether | 20 | | | | | Q | | Q | | | | | | | |
| Phenylethyl Alcohol | 20 | | | | | S | | | | | | | | | |
| Phosphat ester (see Hydrolic Fluids) | 20 | | | | | | | | | | | | | | |
| Phosphate | 20 | | | | R | R | R | | | | | | | | |
| Phosphine | 20 | | | | R | R | R | | | | | | | | |
| Phosgene | 20 | 100 | S | S | | | | | | | | | | | |
| Phosphoric Acid Aq. | 20 | 10 | R | R | Q | Q | S | R | | | | | R | | S |
| Phosphoric Acid Aq. | 60 | 10 | R | R | NR | Q | NR | | | | | | | | |
| Phosphoric Acid Aq. | 20 | 20 | R | R | NR | Q | S | | | | | | | | |
| Phosphoric Acid Aq. | 60 | 20 | R | R | NR | NR | NR | | | | | | | | |
| Phosphoric Acid Aq. | 20 | 85 | R | R | NR | NR | Q | Q | | | | | R | | |
| Phosphoric Acid Aq. | 60 | 85 | R | Q | NR | NR | NR | Q | | | | | | | |
| Phosphoric Anyhdride | 20 | | | | NR | R | | | | | | | | | |
| Phosphorus Pentoxide | 20 | 100 | R | S | S | | | | | | | | | | |
| Phosphorus Pentoxide | 60 | 100 | | | | | | | | | | | | | |
| Phosphorus Trichloride | 20 | | | | NR | | | | | | | | | | |
| Photographic developer | 20 | | R | R | S | R | R | | | | | | | | |
| Photographic developer | 60 | | R | R | Q | | | | | | | | | | |
| Photographic fixer | 20 | | | R | S | R | R | | | | | | | | |
| Photographic fixer | 60 | | | R | Q | | | | | | | | | | |
| Phthalic Acid Aq. | 20 | | R | R | R | S | R | | | | | | | | |
| Phthalic Anhydride | 20 | | | | S | R | | | | | | | | | |
| Pickling Baths | 20 | | | R | | | | | | | | | | | |
| Pickling Baths | 60 | | | R | | | | | | | | | | | |
| Picric Acid | 20 | | | | R | R | | | | | | | | | |
| Plastomoll | 20 | | | | R | R | R | | | | | | | | |
| Polyglycols, polyols | 20 | | | | R | R | R | | | | | | | | |
| Polyvinyl Acetate | 20 | | R | | R | R | | | | | | | | | |
| Potash (Potassium Carbonate) | 20 | | R | | | R | | | | | | | | | |
| Potassium Bicarbonate | 20 | | R | R | S | R | | R | | | | | | | |
| Potassium Bicarbonate | 60 | | R | R | Q | R | | S | | | | | | | |

Chemical Resistance Chart

| Chemical | Temperature °C | Concentration % | PP | PE | POM | PA | PET/PBT | PC | GR | PP + GF | PA + GF | PVDF | PSU | TEFLON | TPE |
|--|----------------|-----------------|----|----|-----|----|---------|----|----|---------|---------|------|-----|--------|-----|
| | | | | | | | | | | | | | | | |
| Silicone oils | 20 | | R | S | R | R | R | R | | | | | | | |
| Silver Bromide | 20 | | | | Q | | | | | | | | | | |
| Silver Cyanide | 20 | | | R | | | | | | | | | | | |
| Silver Nitrate | 20 | | R | R | Q | R | R | S | | | | | | | |
| Silver Nitrate | 60 | | R | R | NR | | | | | | | | | | |
| Soap Solutions | 20 | 10 | R | R | R | R | R | | | | | | | | R |
| Soap Solutions | 60 | 50 | | R | | | NR | | | | | | | | |
| Soda solution | 20 | 10 | | | R | R | R | | | | | | | | R |
| Soda Ash (see Sodium Carbonate) | 20 | | R | | | | | | | | | | | | |
| Sodium Acetate Aq. | 20 | | R | R | S | R | | | | | | | | | |
| Sodium Acetate Aq. | 60 | | | R | | | | | | | | | | | |
| Sodium Acid Sulphate (see Sodium Bisulphate) | 20 | | | | | | | | | | | | | | |
| Sodium Aluminate | 20 | | | R | S | R | | | | | | | | | |
| Sodium Antimonate | 20 | | | R | | | | | | | | | | | |
| Sodium Benzoate | 20 | 35 | R | R | | | | | | | | | | | |
| Sodium Benzoate | 60 | 35 | R | R | | | | | | | | | | | |
| Sodium Bicarbonate Aq. | 20 | | R | R | R | R | | | | | | | | | |
| Sodium Bicarbonate Aq. | 60 | | R | R | R | R | | | | | | | | | |
| Sodium Bisulphate | 20 | | R | R | S | Q | | | | | | | | | |
| Sodium Bisulphate | 60 | | R | R | S | Q | | | | | | | | | |
| Sodium Bisulphite | 20 | | R | R | Q | NR | R | | | | | | | | |
| Sodium Bisulphite | 60 | | R | R | Q | NR | R | | | | | | | | |
| Sodium Borate (Borax) | 20 | | | R | | R | | | | | | | | | |
| Sodium Borate (Borax) | 60 | | | R | | R | | | | | | | | | |
| Sodium Bromide | 20 | 10 | | R | R | S | | | | | | | | | |
| Sodium Bromide | 60 | 10 | | R | R | | | | | | | | | | |
| Sodium Carbonate | 20 | 10 | R | R | R | S | R | | | | | | | | |
| Sodium Carbonate | 60 | 10 | R | R | R | S | R | | | | | | | | |
| Sodium Chlorate | 20 | 10 | R | R | R | R | R | | | | | | | | |
| Sodium Chlorate | 60 | 10 | R | R | R | R | | | | | | | | | |
| Sodium Chloride | 20 | 10 | R | R | R | S | R | R | | | | | | | |
| Sodium Chloride | 60 | 10 | R | R | R | Q | R | | | | | | | | |
| Sodium Chromate | 20 | | R | | NR | R | | | | | | | | | |
| Sodium Chromate | 60 | | R | | NR | | | | | | | | | | |
| Sodium Cyanide | 20 | | R | R | R | S | R | | | | | | | | |
| Sodium Cyanide | 60 | | R | R | R | Q | | | | | | | | | |
| Sodium Dichromate | 20 | | | R | | R | S | | | | | | | | |
| Sodium Dichromate | 60 | | | R | | | | | | | | | | | |
| Sodium Dodecylbenzenesulfonate | 20 | | | | R | R | R | | | | | | | | |
| Sodium Ferricyanide | 20 | | | R | | | | | | | | | | | |
| Sodium Ferricyanide | 60 | | | R | | | | | | | | | | | |
| Sodium Ferrocyanide | 20 | | | R | R | | | | | | | | | | |
| Sodium Ferrocyanide | 60 | | | R | R | | | | | | | | | | |
| Sodium Fluoride | 20 | | | R | | R | | | | | | | | | |
| Sodium Fluoride | 60 | | | R | | R | | | | | | | | | |
| Sodium Hydrogen carbonate | 20 | 10 | R | | R | R | R | | | | | | | | |
| Sodium hydrogen Sulfate | 20 | 10 | | | | R | R | | | | | | | | |
| Sodium Hydrogen Sulfit | 20 | 10 | | | Q | R | R | | | | | | | | |
| Sodium Hydroslufite | 20 | | | | | | | | | | | | | | |
| Sodium Hydroxide | 20 | 10 | R | R | R | S | Q | Q | | | | | | | |
| Sodium Hydroxide | 60 | 10 | R | R | Q | NR | Q | Q | | | | | | | |
| Sodium Hydroxide | 20 | 50 | R | R | S | Q | Q | Q | | | | | | | |
| Sodium Hydroxide | 60 | 50 | R | R | Q | | | | | | | | | | |
| Sodium Hydroxide | 20 | 80 | R | R | NR | | | | | | | | | | |
| Sodium Hydroxide | 60 | 80 | R | R | NR | | | | | | | | | | |
| Sodium Hypochlorite Chlorine Bleach | 20 | 10 | R | R | S | S | S | Q | | | | | | | |

Technical Data Sheet for Belt & Chain Applications | Metric

| |
|-------------------|
| Company/Customer: |
| Contact person: |
| End user: |

Technical Data

| | | | | | | |
|--|--|--|-----|--|-----|---|
| 1. Industry: | | | | | | |
| 2. Application: | | | | | | |
| 3. Product type: | | | | | | |
| 4. Wrapping/Container: <input type="checkbox"/> None <input type="checkbox"/> Plastic containers <input type="checkbox"/> Cardboard <input type="checkbox"/> Shrink wrapped <input type="checkbox"/> Flow pack <input type="checkbox"/> Wood | | | | | | |
| <input type="checkbox"/> Plastic trays <input type="checkbox"/> Steel trays <input type="checkbox"/> Glass <input type="checkbox"/> Steel cans <input type="checkbox"/> Alu cans <input type="checkbox"/> Cross strapped <input type="checkbox"/> Other: | | | | | | |
| 5. Item size (mm) L: | | xW: | xH: | or Ø: | xH: | Other: |
| 6. Product weight: | | kg/item | | kg/m | | kg/m ² |
| 7. Throughput: | | items/min. | | kg/min. | | Speed m/min. |
| 8. Length of conveyor C-C: | | m | | Length of belt/chain: | | m Width of belt: m |
| 9. Start/stop operation: | | <input type="checkbox"/> No (continuous drive) | | <input type="checkbox"/> Yes, no. of stops per hour | | <input type="checkbox"/> Product indexing |
| 10. Accumulation: | | <input type="checkbox"/> No <input type="checkbox"/> Full | | <input type="checkbox"/> Partly length of accumulation: | | |
| 11. Min./max. operating temp.: | | °C / | | °C | | |
| 12. Is the conveyor lubricated? | | <input type="checkbox"/> Yes, type: | | | | <input type="checkbox"/> No |
| 13. Is the belt/chain exposed to any chemicals during operation? | | <input type="checkbox"/> Yes, type: | | | | <input type="checkbox"/> No |
| 14. Is the belt/chain exposed to any chemicals during cleaning? | | <input type="checkbox"/> Yes, type: | | | | <input type="checkbox"/> No |
| 15. Conveyor type: | | <input type="checkbox"/> Belt or <input type="checkbox"/> Chain | | <input type="checkbox"/> Single row <input type="checkbox"/> Parallel rows | | No. of rows: |
| 16. Layout (birdseye) | | <input type="checkbox"/> Straight running | | <input type="checkbox"/> Sideflexing | | |
| 17. Horizontal layout | | <input type="checkbox"/> Straight <input type="checkbox"/> Incline | | <input type="checkbox"/> Decline- If in-/decline angle to horizontal: | | ° |
| 18. <input type="checkbox"/> New conveyor | | <input type="checkbox"/> Retrofit | | Original belt/chain from: | | |
| 19. Belt type: | | or chain type: | | | | |
| 20. Belt or chain pitch: | | Belt or chain color: | | | | |
| 21. Belt or chain material: | | <input type="checkbox"/> POM <input type="checkbox"/> PP <input type="checkbox"/> PE <input type="checkbox"/> PA | | <input type="checkbox"/> Hardened steel <input type="checkbox"/> Stainless steel | | <input type="checkbox"/> Other: |
| 22. Pin material: | | <input type="checkbox"/> Plastic <input type="checkbox"/> PP <input type="checkbox"/> PE <input type="checkbox"/> PA | | <input type="checkbox"/> Hardened steel <input type="checkbox"/> Stainless steel | | <input type="checkbox"/> Other: |
| 23. Pin retention system: | | | | | | |

Technical Data Sheet for Belt & Chain Applications | Imperial

| |
|-------------------|
| Company/Customer: |
| Contact person: |
| End user: |

Technical Data

| | | | | | |
|--|--|----------------------------------|---|---|--|
| 1. Industry: | | | | | |
| 2. Application: | | | | | |
| 3. Product type: | | | | | |
| 4. Wrapping/Container: <input type="checkbox"/> None <input type="checkbox"/> Plastic containers <input type="checkbox"/> Cardboard <input type="checkbox"/> Shrink wrapped <input type="checkbox"/> Flow pack <input type="checkbox"/> Wood | | | | | |
| <input type="checkbox"/> Plastic trays <input type="checkbox"/> Steel trays <input type="checkbox"/> Glass <input type="checkbox"/> Steel cans <input type="checkbox"/> Alu cans <input type="checkbox"/> Cross strapped <input type="checkbox"/> Other: | | | | | |
| 5. Item size (in.) L: | xW: | xH | or Ø: | xH: | Other: |
| 6. Product weight: | lb/item | | lb/ft | lb/ft ² | |
| 7. Throughput: | items/min. | | lb/min. | Speed | ft/min. |
| 8. Length of conveyor C-C: | ft | Length of belt/chain: | | ft | Width of belt: ft |
| 9. Start/stop operation: | <input type="checkbox"/> No (continuous drive) | | <input type="checkbox"/> Yes, no. of stops per hour | | <input type="checkbox"/> Product indexing |
| 10. Accumulation: | <input type="checkbox"/> No | | <input type="checkbox"/> Full | <input type="checkbox"/> Partly length of accumulation: | |
| 11. Min./max. operating temp.: | °F / | | °F | | |
| 12. Is the conveyor lubricated? | <input type="checkbox"/> Yes, type: | | | <input type="checkbox"/> No | |
| 13. Is the belt/chain exposed to any chemicals during operation? | <input type="checkbox"/> Yes, type: | | | <input type="checkbox"/> No | |
| 14. Is the belt/chain exposed to any chemicals during cleaning? | <input type="checkbox"/> Yes, type: | | | <input type="checkbox"/> No | |
| 15. Conveyor type: | <input type="checkbox"/> Belt or | <input type="checkbox"/> Chain | <input type="checkbox"/> Single row | <input type="checkbox"/> Parallel rows | No. of rows: |
| 16. Layout (birdseye) | <input type="checkbox"/> Straight running | | <input type="checkbox"/> Sideflexing | | |
| 17. Horizontal layout | <input type="checkbox"/> Straight | <input type="checkbox"/> Incline | <input type="checkbox"/> Decline- If in-/decline angle to horizontal: | | ° |
| 18. <input type="checkbox"/> New conveyor | <input type="checkbox"/> Retrofit | | Original belt/chain from: | | |
| 19. Belt type: | or chain type: | | | | |
| 20. Belt or chain pitch: | Belt or chain color: | | | | |
| 21. Belt or chain material: | <input type="checkbox"/> POM | <input type="checkbox"/> PP | <input type="checkbox"/> PE | <input type="checkbox"/> PA | <input type="checkbox"/> Hardened steel <input type="checkbox"/> Stainless steel <input type="checkbox"/> Other: |
| 22. Pin material: | <input type="checkbox"/> Plastic | <input type="checkbox"/> PP | <input type="checkbox"/> PE | <input type="checkbox"/> PA | <input type="checkbox"/> Hardened steel <input type="checkbox"/> Stainless steel <input type="checkbox"/> Other: |
| 23. Pin retention system: | | | | | |

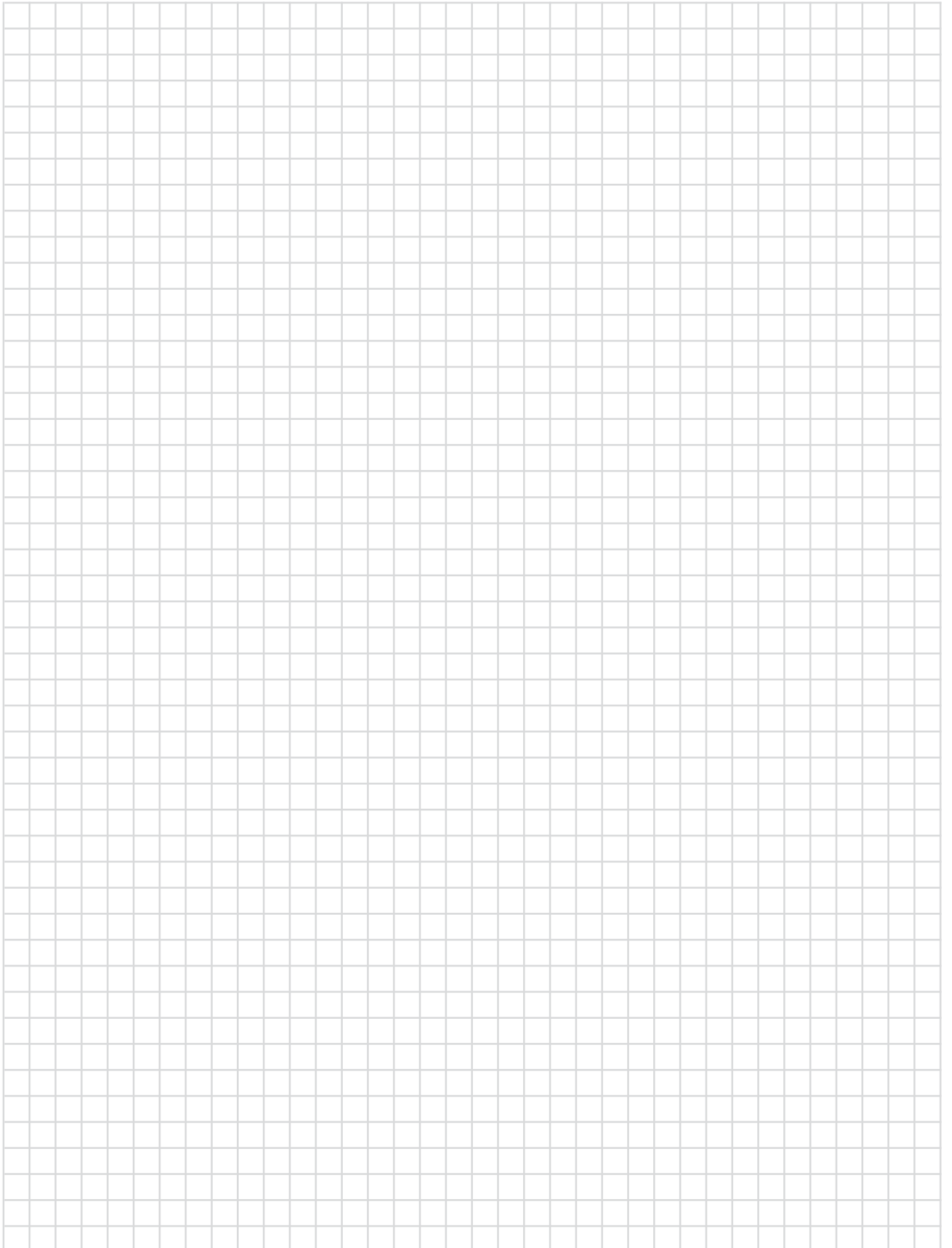

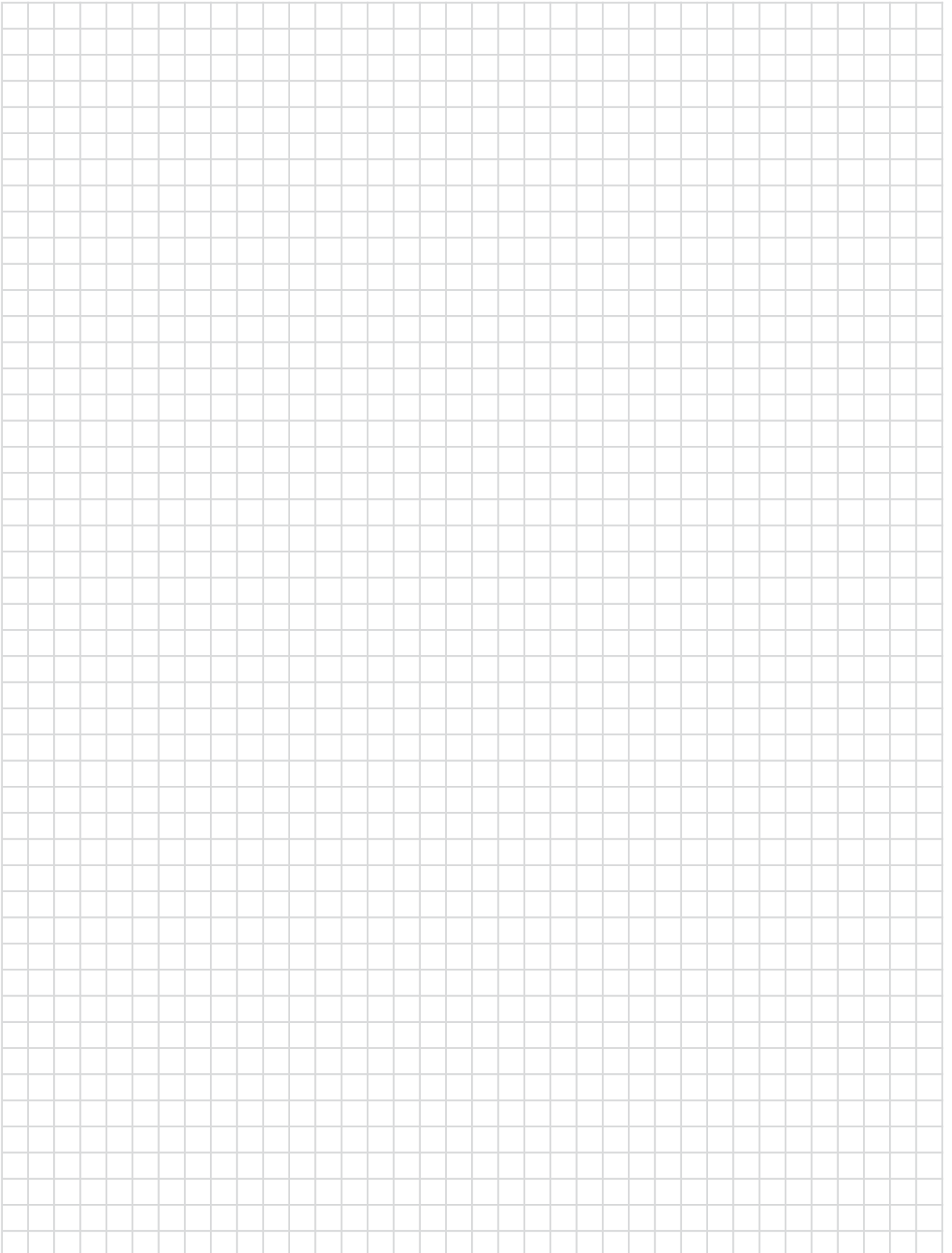

Local Contacts

Authorised distributor Ammeral Beltech:

TYMA CZ, s.r.o.

Na Pískách 731

400 04 Trmčice

Tel: +420 475 655 010

E-mail: info@tyma.cz, <http://www.tyma.cz>

Austria

T +43 171728 133
sales@ammeraalbeltech.de
www.ammeraalbeltech.at

Belgium

T +32 2 466 0300
salesgb@ammeraalbeltech.be
www.ammeraalbeltech.be

Canada

T +1 905 890 1311
info@ammeraalbeltech.ca
www.ammeraalbeltech.com

Chile

T +56 233 12900
ventas@ammeraalbeltech.cl
www.ammeraalbeltech.cl

China

T +86 21 5280 6810
info@ammeraalbeltech.com.cn
www.ammeraalbeltech.com.cn

Czech Republic

T +420 567 117 211
prodej@ammeraalbeltech.cz
www.ammeraalbeltech.cz

Denmark

T +45 75 72 31 00
admin@unichains.com
www.unichains.com

Finland

T +358 207 911 400
info@ammeraalbeltech.fi
www.ammeraalbeltech.fi

France

T +33 3 20 90 36 00
client@ammeraalbeltech.fr
www.ammeraalbeltech.fr

Germany

T +49 4152 937-0
sales@ammeraalbeltech.de
www.ammeraalbeltech.de

Hungary

T +36 30 311 6099
info@ammeraalbeltech.hu
www.ammeraalbeltech.hu

India

T +91 44 265 34 244
info@ammeraalbeltech.net.in
www.ammeraalbeltech.com

Italy

T +39 051 660 60 06
info@ammeraalbeltech.it
www.ammeraalbeltech.it

Luxembourg

T +352 26 48 38 56
sales@ammeraal-beltech.lu
www.ammeraal-beltech.lu

Malaysia

T +60 3 806 188 49
sales.kl@ammeraalbeltech.my
www.ammeraalbeltech.com

Netherlands

T +31 72 57 51212
infoni@ammeraalbeltech.com
www.ammeraalbeltech.nl

Poland

T +48 32 44 77 179
biuro@ammeraalbeltech.com
www.ammeraalbeltech.com

Portugal

T +351 22 947 94 40
geral@ammeraalbeltech.pt
www.ammeraalbeltech.pt

Singapore

T +65 62739767
sales@ammeraalbeltech.sg
www.ammeraalbeltech.com

Slovakia

T +421 2 55648541-2
predaj@ammeraalbeltech.sk
www.ammeraalbeltech.sk

South Korea

T +82 31 448 3613-7
amel@ammeraalbeltech.co.kr
www.ammeraalbeltech.co.kr

Spain

T +34 93 718 3054
ventas@ammeraalbeltech.es
www.ammeraalbeltech.es

Sweden

T +46 44 780 3010
info@ammeraalbeltech.se
www.ammeraalbeltech.se

Switzerland

T +41 55 2253 535
info@ammeraalbeltech.ch
www.ammeraalbeltech.ch

Thailand

T +66 2 902 2604-13
sales@ammeraalbeltech.th.com
www.ammeraalbeltech.com

United Kingdom

T +44 1992 500550
sales@ammeraalbeltech.co.uk
www.ammeraalbeltech.co.uk

United States

T +1 847 673 6720
info@ammeraalbeltechusa.com
www.ammeraalbeltech.com

Vietnam

T +84 8 376 562 05
info@ammeraalbeltech.com.vn
www.ammeraalbeltech.com.vn

Global Headquarters:

Ammeraal Beltech Holding B.V.

P.O. Box 38
1700 AA Heerhugowaard
The Netherlands

T +31 72 575 1212
F +31 72 571 6455

info@ammeraalbeltech.com
www.ammeraalbeltech.com

Expert advice, quality solutions
and local service
for all your belting needs

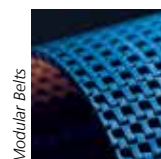
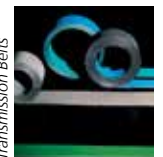
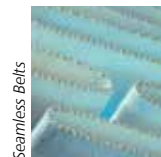
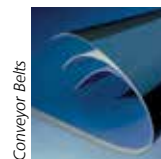

... and 150 service contacts more on www.ammeraalbeltech.com