

Vibration Control

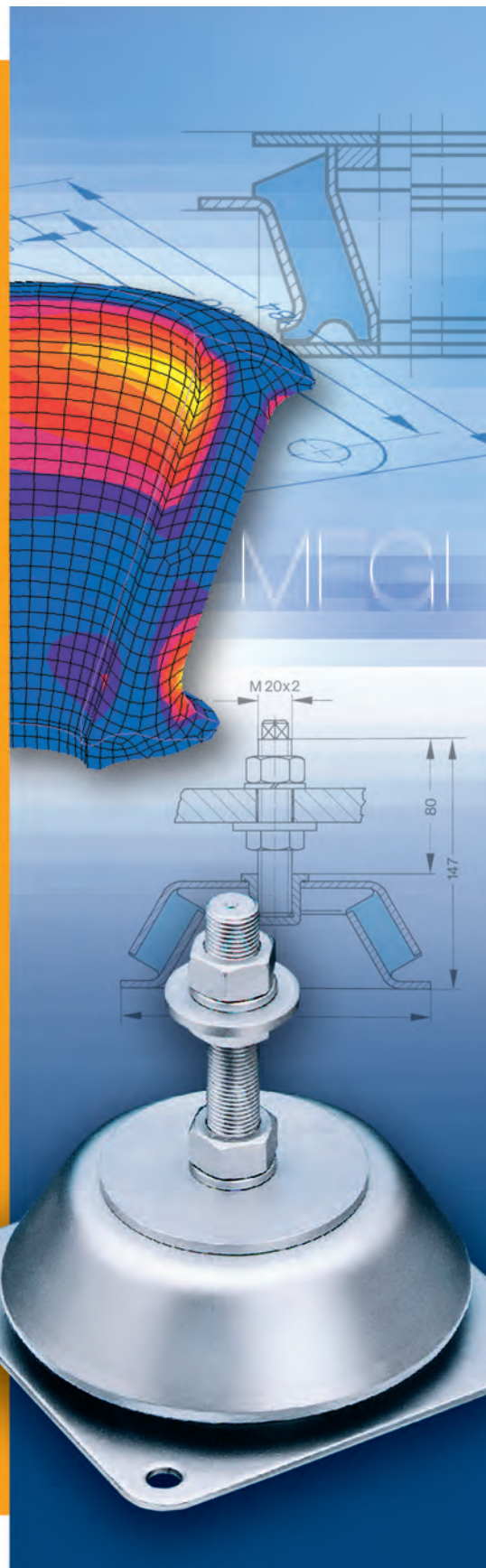

MEGI[®]

Product information and
delivery programme

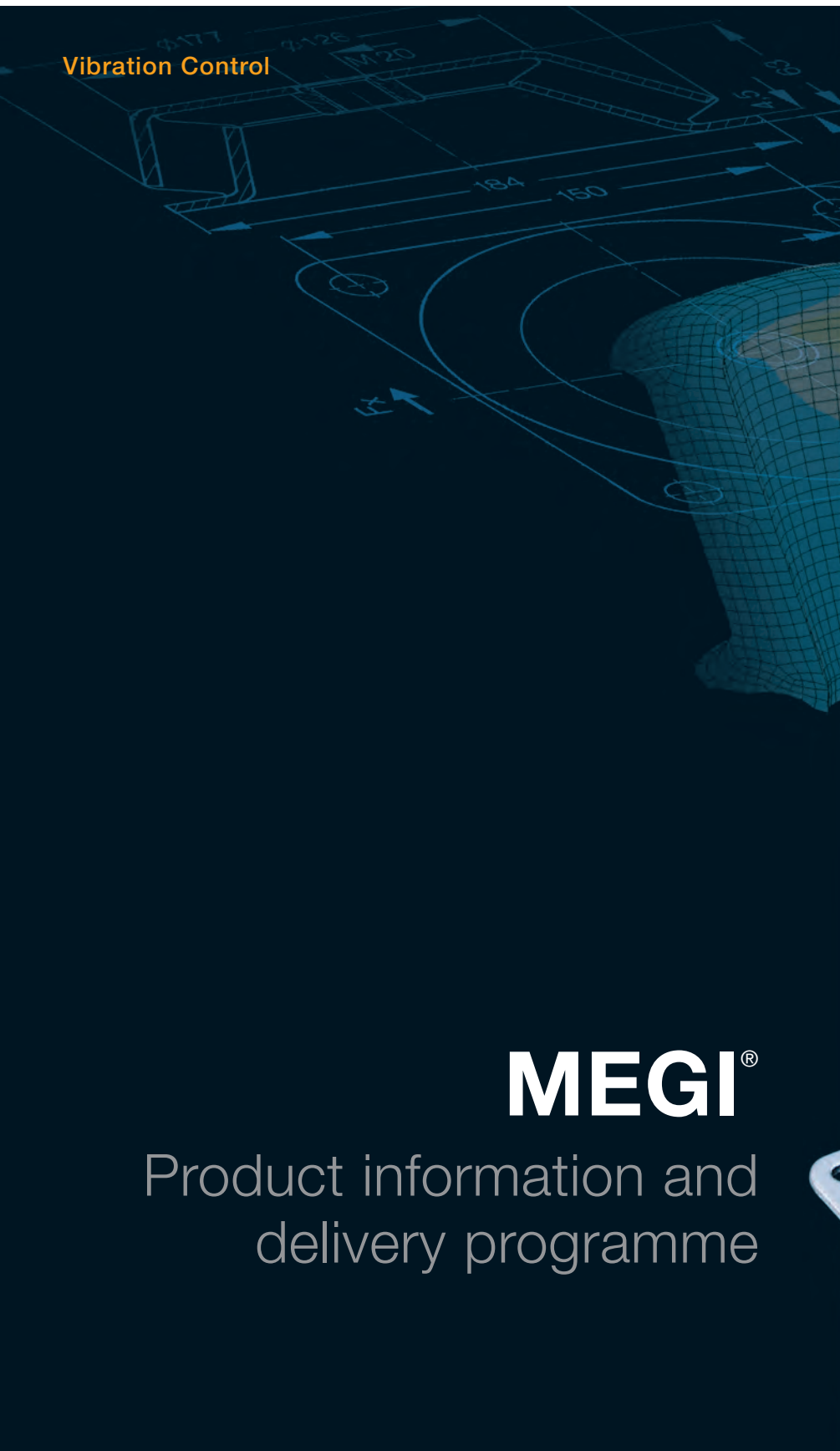
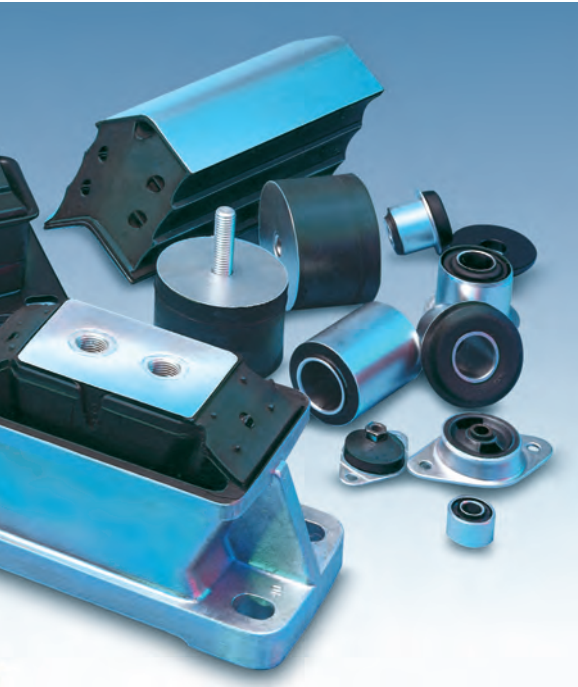

MEGI® = METALLGUMMI (METAL RUBBER)

MEGI and METALLGUMMI are registered trademarks.

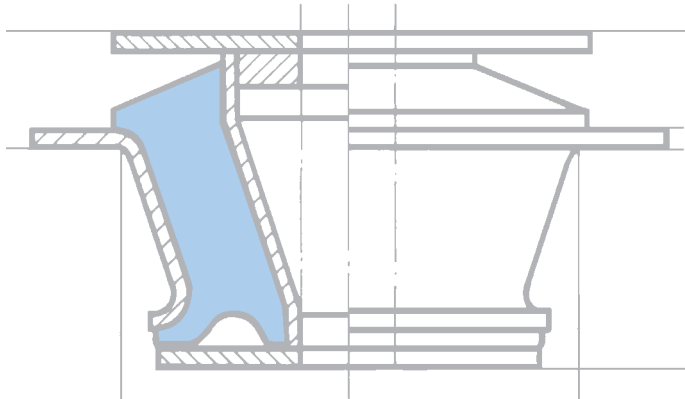

MEGI® Spring Elements

MEGI spring elements are construction elements for use wherever vibration and noise from machines, equipment and systems are to be reduced effectively (passive suppression) as well for protection of the environment (active suppression), or forces have to be transferred without play or friction.

MEGI spring elements are distinguished by the permanent connection between the metal and elastomer as well the highly varying possibilities for application.

The comprehensive MEGI product line offers a spring element for merely every type of application required for vibration damping aspects.

When selecting MEGI spring elements, please observe the corresponding technical data and notes.

| | |
|------|--|
| Page | |
| 4 | MEGI Standard Items: Properties, application, load limits |
| 11 | MEGI Buffer Delivery program |
| 17 | MEGI Stop Buffer Delivery program |
| 23 | MEGI Bars Delivery program |
| 27 | MEGI Machine Mounts with/without tear-off safety device Delivery program |
| 35 | MEGI Cones Delivery program |
| 45 | MEGI Bearings Delivery program |
| 53 | MEGI Ring Elements Delivery program |
| 57 | MEGI-U-V-W Shaped Parts MEGI Ceiling Elements Delivery program |
| 63 | MEGI Bushes MEGI Rings Delivery program |
| 67 | Material Information Basis for Calculations |

MEGI Standard Items: Properties, Application, Load Limits

Product group: MEGI buffers

| Particular characteristics | Typical applications | Possible types of loads/directions | Static load limits | Notes |
|--|---|--|------------------------------|---|
| <ul style="list-style-type: none"> Simple, reasonably priced standard components Simple to mount | Mounting light to medium-heavy equipment, electric motors and internal combustion engines, compressors, pumps, jolting and vibration machines | <ul style="list-style-type: none"> Pressure Thrust Compound loads | $F_{Z_{max.}} 30 \text{ kN}$ | <p>Strength class of threaded joint: 5. Other strength classes available on request.</p> <p>No tension load permissible on part.</p> <p>Protection against corrosion: Zinc coated and colourless passivated</p> |

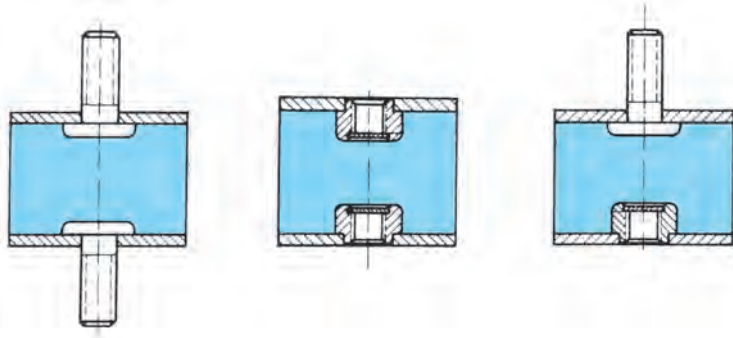

Product group: MEGI buffers with enlarged adhesive surface

| Particular characteristics | Typical applications | Possible types of loads/directions | Static load limits | Notes |
|---|---|--|---|---|
| <ul style="list-style-type: none"> Simple, reasonably priced standard components Simple to mount Less sensitive than conventional buffers to rarely occurring tension loads Higher dynamic peak loads possible than with conventional version | Mounting equipment, electric motors and internal combustion engines, compressors, pumps, jolting and vibration machines | <ul style="list-style-type: none"> Pressure Thrust Compound loads | $F_{Z_{max.}} 5,2 \text{ kN}$ (Higher dynamic peak loads possible) | <p>Strength class of threaded joint: 5. Other strength classes available on request.</p> <p>No tension load permissible on part.</p> <p>Protection against corrosion: Zinc coated and colourless passivated</p> |

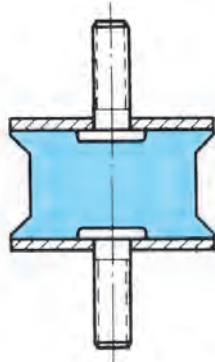

Product group: MEGI Stop Buffer

| Particular characteristics | Typical applications | Possible types of loads/directions | Static load limits | Notes |
|--|---|---|--------------------------------------|--|
| <ul style="list-style-type: none"> Simple, reasonably priced standard components Simple to mount | Limitation of motion, end position damping, supporting thrust loads, mounting machines and equipment without fastening to foundation. | <ul style="list-style-type: none"> Pressure Limited pressure/thrust (rubber abrasion due to friction) | $F_{Z_{max.}}$ 50 kN (Fender buffer) | Strength class of threaded joint: 5. Other strength classes available on request. Protection against corrosion: Zinc coated and colourless passivated |

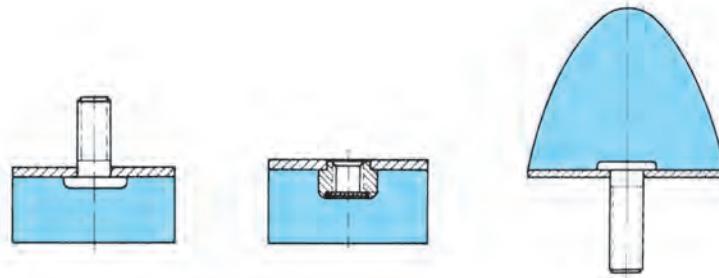

Product group: MEGI bars

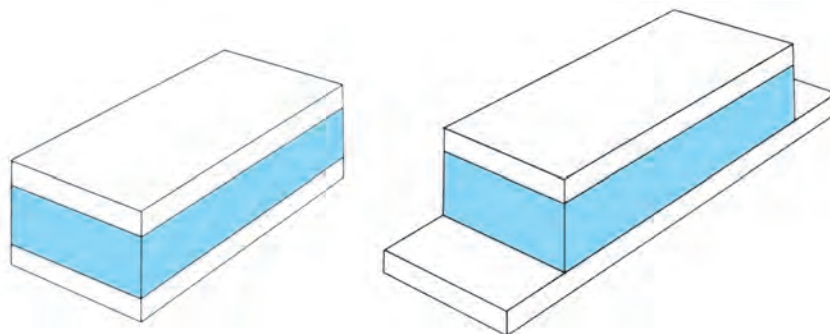
| Particular characteristics | Typical applications | Possible types of loads/directions | Static load limits | Notes |
|---|--|--|-----------------------|--------------------------------------|
| <ul style="list-style-type: none"> High specific pressure load bearing capacity Can be prefabricated and adapted to mounting conditions on a custom-tailored basis Delivery length up to 2000 mm | Mounting medium-heavy to heavy equipment, electric motors and internal combustion engines, heavy machines, machine tools, machines for passenger and cargo elevators, jolting and vibration machines | <ul style="list-style-type: none"> Pressure Thrust Compound loads | $F_{Z_{max.}}$ 800 kN | No tension load permissible on part. |

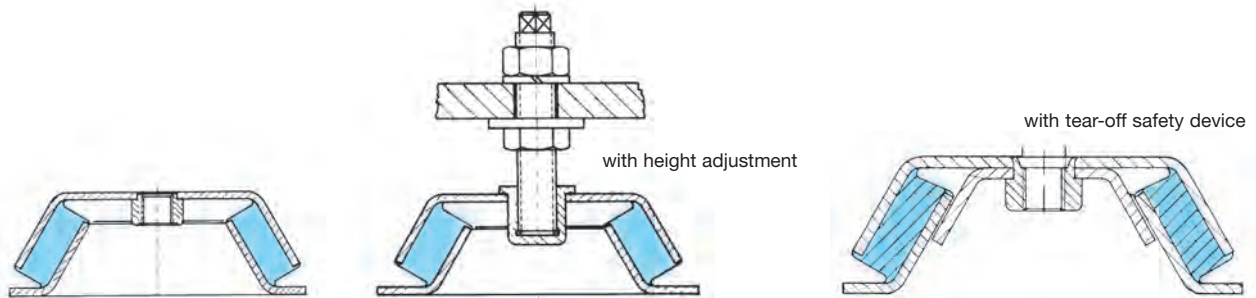

Product group: MEGI Machine Mounts

| Particular characteristics | Typical applications | Possible types of loads/directions | Static load limits | Notes |
|--|---|---|-----------------------------|---|
| <ul style="list-style-type: none"> ■ Rigidity ratio vertical/horizontal nearly 1 ■ Extremely good horizontal guidance ■ Vertical and horizontal rigidities can be changed by mounting to Machine Mounts next to one another in series | Mounting eccentric presses, planing machines, printing presses and textile machines, electric motors and internal combustion engines, machine tools | <ul style="list-style-type: none"> - X, Y, Z - Compound loads | $F_{Z\max.}$ up to 21 kN | <p>Strength class of central threaded joint: 5. Other strength classes available on request.</p> <p>No tension load permissible on part.</p> <p>Protection against corrosion: Zinc coated and colourless passivated</p> |



Product group: MEGI cones

| Particular characteristics | Typical applications | Possible types of loads/directions | Static load limits | Notes |
|--|--|---|-----------------------------|---|
| <ul style="list-style-type: none"> ■ Impact plates for progressive axial absorption and tear-off protection ■ Extremely good horizontal guidance ■ Optional varying horizontal rigidities | Mounting electric motors and internal combustion engines, body structures, compressors | <ul style="list-style-type: none"> - X, Y, Z - Compound loads | $F_{Z\max.}$ up to 16 kN | <p>Observe maximum pretension forces for central mounting bolt. Other strength classes available on request.</p> <p>No tension load permissible on part.</p> <p>Protection against corrosion: Zinc coated and colourless passivated</p> |

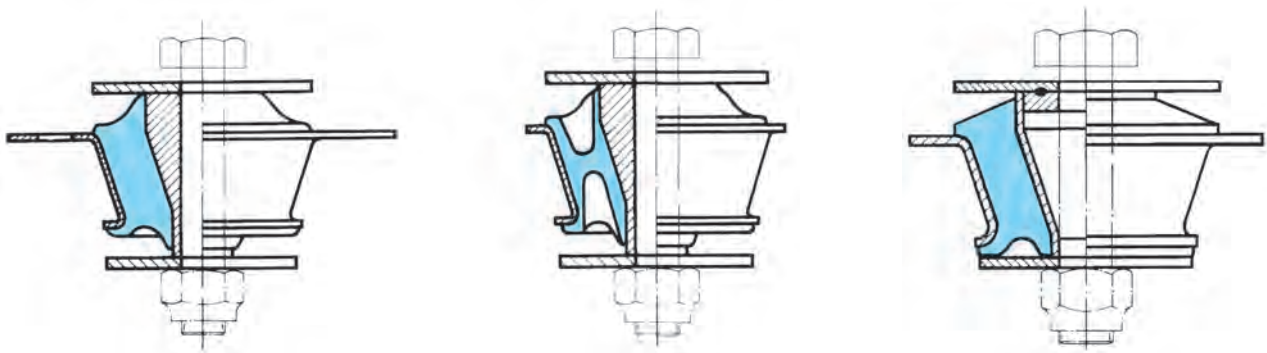

Product group: MEGI bearings

| Particular characteristics | Typical applications | Possible types of loads/directions | Static load limits | Notes |
|---|--|------------------------------------|------------------------|---|
| <ul style="list-style-type: none"> Special vertical/horizontal rigidity ratios Simple to mount with housing | Mounting electric motors and internal combustion engines, compressors. | - X, Y, Z - Compound loads | $F_{Z\max}$ up to 6 kN | Strength class of threaded joint: 5. Other strength classes available on request. No tension load permissible on part. |

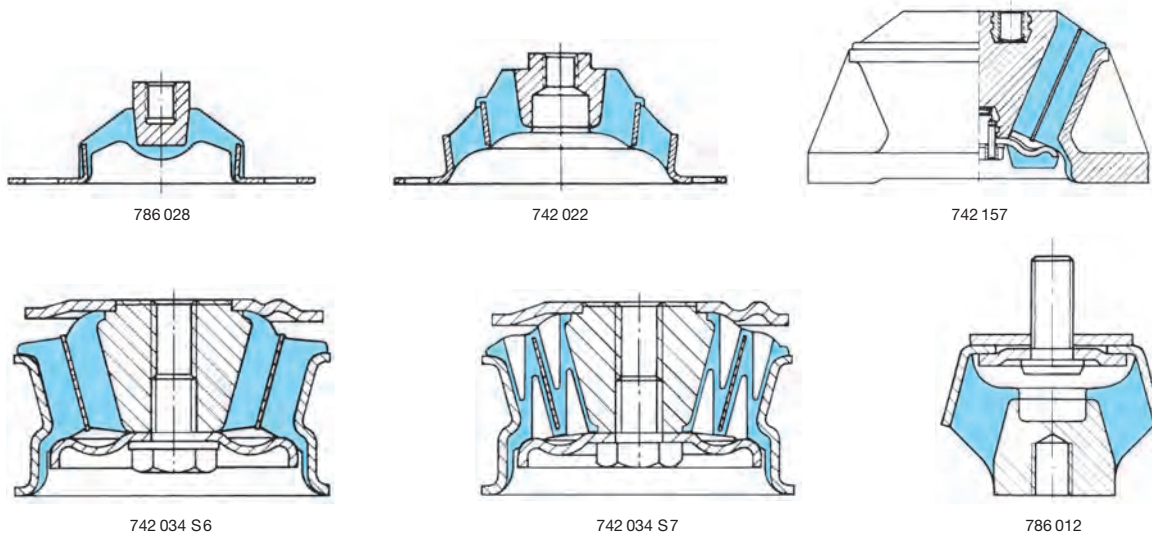
Product group: MEGIFLEX disks

| Particular characteristics | Typical applications | Possible types of loads/directions | Static load limits | Notes |
|--|--|------------------------------------|--------------------------------------|--|
| <ul style="list-style-type: none"> High specific pressure loading capacity Spring characteristics can be adjusted by using a combination of several elements Can be assembled as tension/pressure spring assembly | Mounting machines and equipment, electric motors and internal combustion engines. Used as, torque supports and for suspension of swing arms and ends of leaf springs in vehicle construction. Various systems can be combined to form thrust and tension assemblies. | - Pressure | $F_{Z\max}$ 82,4 kN (MEGIFLEX-disks) | It is necessary to secure higher spring assemblies against resilient buckling and lateral loads. |

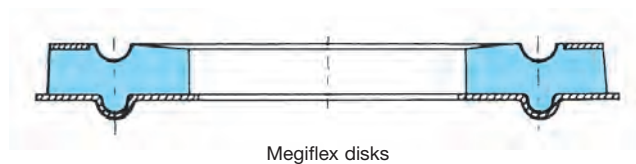

Megiflex disks

Product group: MEGI annular buffers

| Particular characteristics | Typical applications | Possible types of loads/directions | Static load limits | Notes |
|--|---|------------------------------------|---|---|
| <ul style="list-style-type: none"> Can be combined as tension/pressure spring assembly Simple to mount | Mounting light to medium-heavy machines and equipment, electric motors and internal combustion engines, cabs, pipelines and equipment cabinets. | - Pressure | $F_{z,max.}$ 6,1 kN (individual annular buffers) | Two spring elements can be pretensioned against one another to achieve double pressure spring rigidity for the spring assembly. |

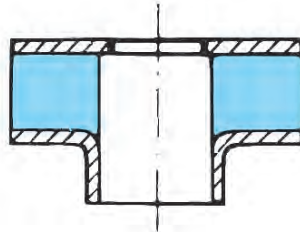

Megi annular buffers

Product group: MEGI-U-V-W shaped parts

| Particular characteristics | Typical applications | Possible types of loads/directions | Static load limits | Notes |
|---|---|---|--------------------|---|
| <ul style="list-style-type: none"> Soft support Various rigidities in three spatial directions (U elements) | Mounting sensitive equipment, apparatus, measuring instruments and equipment. | F_z for U element F_y and F_z for V and W elements | 950 N | Strength class of threaded joint: 5. Other strength classes available on request. No tension load permissible on part. |

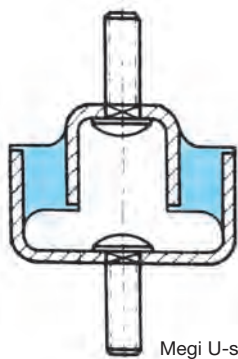

Megi U-shaped element

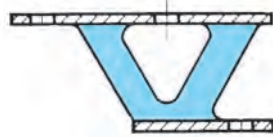

Megi V-shaped element

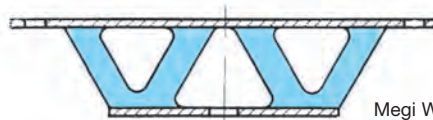

Megi W-shaped element

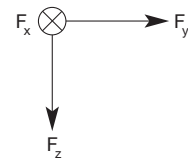

Product group: MEGI ceiling elements

| Particular characteristics | Typical applications | Possible types of loads/directions | Static load limits | Notes |
|---|--|------------------------------------|----------------------------|---|
| <ul style="list-style-type: none"> ■ Tear-off proof ■ Can take up tension loads | Mounting pipelines, illumination elements and ceiling suspensions. | Tension | $F_{Z,max.} 280 \text{ N}$ | Strength class of threaded joint: 5. Other strength classes available on request. |

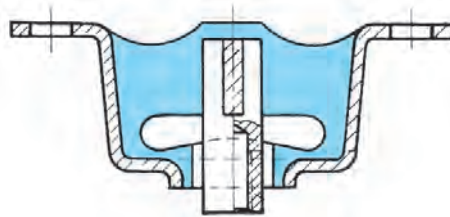
Product group: MEGI HL bushes

| Particular characteristics | Typical applications | Possible types of loads/directions | Static load limits | Notes |
|--|---|--|--|---|
| <ul style="list-style-type: none"> ■ Can be loaded in radial, axial, torsional and cardanic loads | Mounting electric motors and internal combustion engines, axles and pivot arms in vehicle construction as well as machines and equipment. Also use as resilient joints. | <ul style="list-style-type: none"> - Radial pressure - Axial pressure - Torsion - Cardanic - Compound loads | <ul style="list-style-type: none"> - Radial: 14,7 kN - Axial: 6,3 kN | The outer and inner tube must be clamped rigidly to transfer torsion loads. |

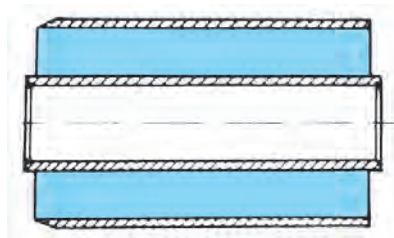

Megi HL bushes

Product group: MEGI AS bushes

| Particular characteristics | Typical applications | Possible types of loads/directions | Static load limits | Notes |
|---|----------------------|--|--|---|
| <ul style="list-style-type: none"> ■ Properties same as MEGI HL bushes, however, stiffer axially | See MEGI HL bushes | <ul style="list-style-type: none"> - Radial pressure - Axial pressure - Torsion - Cardanic - Compound loads | <ul style="list-style-type: none"> - Radial: 3,4 kN - Maximum axial load depends on axial pretension | The outer and inner tube must be clamped rigidly to transfer torsion loads and axial forces |

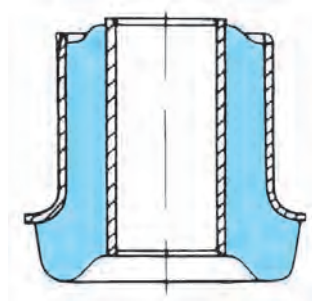

Megi AS bushes

Product group: MEGI rings

| Particular characteristics | Typical applications | Possible types of loads/directions | Static load limits | Notes |
|--|---|--|--|--|
| <ul style="list-style-type: none"> ■ Large torsional twist possible | Mounting axles and pivot arms in vehicle construction. Use as resilient joints. | <ul style="list-style-type: none"> - Radial pressure - Axial pressure - Torsion - Cardanic - Compound loads | <ul style="list-style-type: none"> - Radial: 2,2 kN - Axial: 1,55 kN - Torsional moment 28,4 Nm | When installing, it is necessary to pretension the outer bush radially |

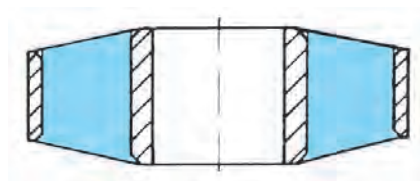

Megi rings

MEGI® Buffers



Applications

Megi buffers are simple, reasonably priced standard elements for flexible bearing arrangements. They are used successfully in general mechanical engineering, light engineering, printing press manufacture and pump manufacture, in the electrical industry and in many other fields. The various construction types (threaded bolt, weld nut) provide an appropriate means of mounting the elements in practically every case).

Description

Megi buffers can be subjected to either shearing or compressive loads, or to both when mounted at an angle to each other. While the high degree of stiffness is desirable for compressive stress, especially for high kinetic and impact loads, the high degree of flexibility to shear stress provides good vibration isolation. If the Megi buffers are subject only to shearing stress, pre-compression has a favourable effect on the service life. Megi buffers with an enlarged rubber-to-metal bonding surface are particularly suitable for high peak dynamic stress. These parts are zinc coated and colourless passivated.

Technical Data

Megi buffers cover a load range up to 30 kN depending on the application and type of rubber used. The maximum tightening torque for the central threaded connection can be selected according to strength class 5.



Delivery

Depending on the item, the Megi buffers are available from stock in standard packages or as catalogue goods producible on short notice.



MEGI® = METALLGUMMI® (Rubber Metal)
Registered trademark.

Supply Programme MEGI® Buffer

Megi buffers with threaded stud
on both sides
Part No. 781...
Versions: hard, medium, soft

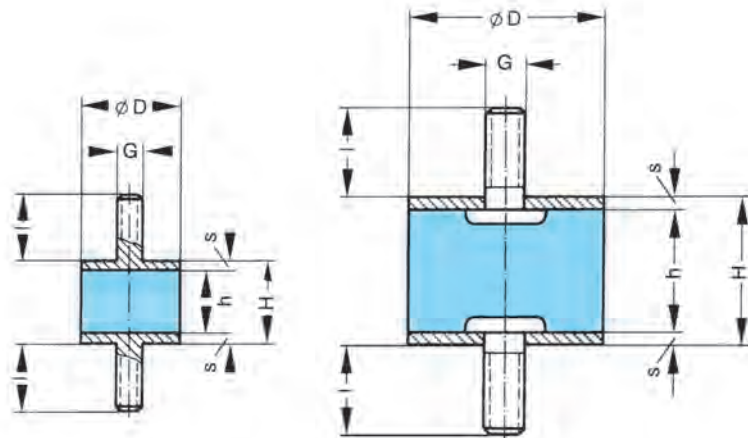

| Dimensions in mm | | | | | | Technical data | | | | | | | | | Number in Part No. package | | | | |
|---------------------|-----|-----|-----|-----|------|---------------------------|--------|------|-------------------------------|--------|------|-------------------------------|--------|------|----------------------------------|--------|------|------------|-----|
| | | | | | | Compression stress | | | | | | Shear stress | | | | | | | |
| D | H | h | s | G | l | Spring rate c_z in N/mm | | | Perm. load $F_{Perm.}$ * in N | | | Spring rate $c_{x,y}$ in N/mm | | | Perm. load $F_{Perm.}$ * in N | | | | |
| | | | | | | hard | medium | soft | hard | medium | soft | hard | medium | soft | hard | medium | soft | | |
| 18 | 8,5 | 4,5 | 2 | M 6 | 11 | 800 | 500 | 300 | 540 | 340 | 200 | 80 | 50 | 30 | 120 | 70 | 40 | 781 040 S1 | 100 |
| 18 | 8,5 | 4,5 | 2 | M 6 | 16 | 800 | 500 | 300 | 540 | 340 | 200 | 80 | 50 | 30 | 120 | 70 | 40 | 781 040 | 100 |
| 20 | 15 | 11 | 2 | M 6 | 16 | 290 | 180 | 110 | 480 | 300 | 180 | 50 | 30 | 20 | 190 | 110 | 70 | 781 050 | 100 |
| 25 | 20 | 14 | 3 | M 6 | 16 | 350 | 220 | 130 | 740 | 460 | 270 | 60 | 40 | 20 | 300 | 190 | 110 | 781 060 | 60 |
| 30 | 15 | 10 | 2,5 | M 8 | 21 | 940 | 590 | 340 | 1400 | 880 | 520 | 110 | 70 | 40 | 390 | 250 | 150 | 781 070 | 60 |
| 30 | 15 | 11 | 2 | M10 | 18 | 680 | 420 | 250 | 1120 | 700 | 410 | 80 | 50 | 30 | 330 | 200 | 120 | 781 130 | - |
| 30 | 20 | 14 | 3 | M 8 | 21 | 570 | 360 | 210 | 1190 | 750 | 440 | 90 | 60 | 30 | 440 | 280 | 160 | 781 071 | 60 |
| 30 | 30 | 24 | 3 | M 8 | 20 | 260 | 160 | 90 | 920 | 580 | 340 | 50 | 30 | 20 | 430 | 270 | 160 | 781 072 | 60 |
| 40 | 30 | 24 | 3 | M 8 | 21 | 510 | 320 | 190 | 1840 | 1150 | 680 | 90 | 60 | 30 | 780 | 490 | 240 | 781 080 | 20 |
| 40 | 40 | 34 | 3 | M 8 | 21 | 320 | 200 | 120 | 1620 | 1020 | 600 | 60 | 40 | 20 | 770 | 480 | 280 | 781 081 | 20 |
| 50 | 20 | 14 | 3 | M10 | 18,5 | 2430 | 1520 | 890 | 5100 | 3190 | 1880 | 240 | 150 | 90 | 1120 | 760 | 450 | 781 090 S1 | 12 |
| 50 | 24 | 18 | 3 | M10 | 26,5 | 1490 | 930 | 550 | 4020 | 2510 | 1480 | 190 | 120 | 70 | 1230 | 770 | 450 | 781 090 | 12 |
| 50 | 30 | 24 | 3 | M10 | 26,5 | 900 | 550 | 330 | 3220 | 2010 | 1180 | 140 | 90 | 50 | 1210 | 760 | 440 | 781 091 | 12 |
| 50 | 40 | 34 | 3 | M10 | 26,5 | 540 | 340 | 200 | 2770 | 1730 | 1020 | 100 | 60 | 40 | 1250 | 780 | 460 | 781 092 | 12 |
| 50 | 45 | 39 | 3 | M10 | 26,5 | 430 | 270 | 160 | 2530 | 1580 | 930 | 90 | 50 | 30 | 1200 | 750 | 440 | 781 112 | 12 |
| 75 | 25 | 19 | 3 | M12 | 39 | 4480 | 2800 | 1650 | 12770 | 7980 | 4690 | 400 | 250 | 150 | 2750 | 1720 | 1010 | 781 100 | 12 |
| 75 | 55 | 49 | 3 | M12 | 39 | 640 | 400 | 235 | 4700 | 2940 | 1730 | 120 | 70 | 40 | 2090 | 1300 | 770 | 781 102 | 4 |
| 100 | 30 | 24 | 3 | M16 | 44 | 6160 | 3850 | 2260 | 22170 | 13860 | 8150 | 510 | 320 | 190 | 4470 | 2780 | 1640 | 781 110 S2 | 4 |
| 100 | 40 | 34 | 3 | M16 | 44 | 2980 | 1860 | 1090 | 15180 | 9480 | 5580 | 360 | 220 | 130 | 4410 | 2760 | 1620 | 781 110 | - |
| 100 | 60 | 54 | 3 | M16 | 44 | 1360 | 850 | 500 | 11020 | 6890 | 4050 | 230 | 140 | 80 | 4440 | 2780 | 1630 | 781 111 | 4 |

* $F_{Perm.}$ is the permissible continuous static load upon which a fluctuating dynamic load can be superimposed. The permissible loads given represent only approximate guide values for the static load.

Stock items: Available only in standard packages.
All items not marked in blue are listed in the catalogue and can be produced on request. Supply quantities on request.

Supply Programme MEGI® Buffer

Megi buffers with female thread on both sides
 Part No. 781...
 Versions: hard, medium, soft

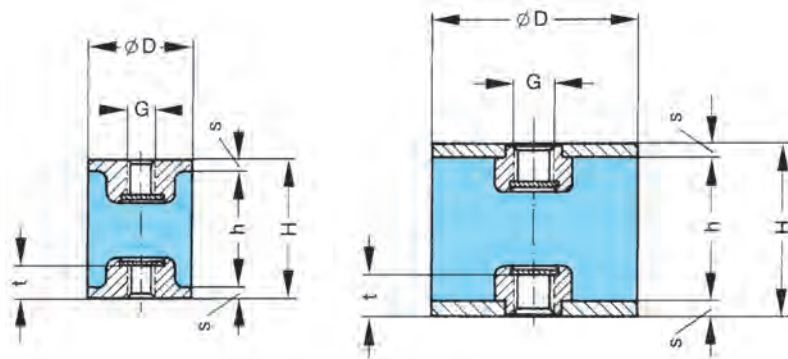

| Dimensions in mm | | | | | | Technical data | | | | | | | | | Number in Part No. package | | | | |
|------------------|-----|----|-----|-----|------|---------------------------|--------|------|-------------------------------|--------|-------|-------------------------------|--------|------|-------------------------------|--------|------|------------|----|
| | | | | | | Compression stress | | | | | | Shear stress | | | | | | | |
| D | H | h | s | G | t | Spring rate c_z in N/mm | | | Perm. load $F_{Perm.}^*$ in N | | | Spring rate $c_{x,y}$ in N/mm | | | Perm. load $F_{Perm.}^*$ in N | | | | |
| | | | | | | hard | medium | soft | hard | medium | soft | hard | medium | soft | hard | medium | soft | | |
| 20 | 25 | 22 | 1,5 | M 6 | 6,5 | 190 | 120 | 70 | 270 | 170 | 100 | 40 | 25 | 15 | 130 | 80 | 50 | 781 054 | 80 |
| 30 | 30 | 24 | 3 | M 8 | 9,5 | 570 | 360 | 210 | 690 | 430 | 250 | 80 | 50 | 30 | 240 | 150 | 90 | 781 074 | 60 |
| 40 | 30 | 24 | 3 | M 8 | 9,5 | 880 | 550 | 320 | 1060 | 660 | 390 | 140 | 80 | 50 | 370 | 230 | 130 | 781 084 | 40 |
| 40 | 40 | 34 | 3 | M 8 | 9,5 | 370 | 230 | 140 | 990 | 620 | 360 | 80 | 50 | 30 | 530 | 330 | 190 | 781 085 | 40 |
| 50 | 30 | 24 | 3 | M10 | 10,5 | 1680 | 1050 | 620 | 1520 | 950 | 560 | 220 | 140 | 80 | 480 | 300 | 180 | 781 094 S1 | 20 |
| 50 | 40 | 34 | 3 | M10 | 10,5 | 660 | 410 | 240 | 1570 | 980 | 580 | 140 | 80 | 50 | 750 | 470 | 280 | 781 094 | 20 |
| 75 | 50 | 44 | 3 | M12 | 12,5 | 980 | 610 | 360 | 3620 | 2010 | 1180 | 190 | 120 | 70 | 1540 | 960 | 560 | 781 104 | 12 |
| 100 | 60 | 54 | 3 | M16 | 16,5 | 1360 | 850 | 500 | 4900 | 3060 | 1800 | 250 | 150 | 90 | 2100 | 1310 | 770 | 781 114 | 4 |
| 200 | 100 | 90 | 5 | M20 | 17,5 | 3250 | 2030 | 1190 | 30200 | 18880 | 11100 | 460 | 290 | 170 | 10460 | 6540 | 3850 | 781 134 | - |

* $F_{Perm.}$ is the permissible continuous static load upon which a fluctuating dynamic load can be superimposed. The permissible loads given represent only approximate guide values for the static load.

Stock items: Available only in standard packages.
 All items not marked in blue are listed in the catalogue and can be produced on request. Supply quantities on request.

Supply Programme MEGI® Buffer

Megi buffers with female thread and threaded stud
 Part No. 781...
 Versions: hard, medium, soft

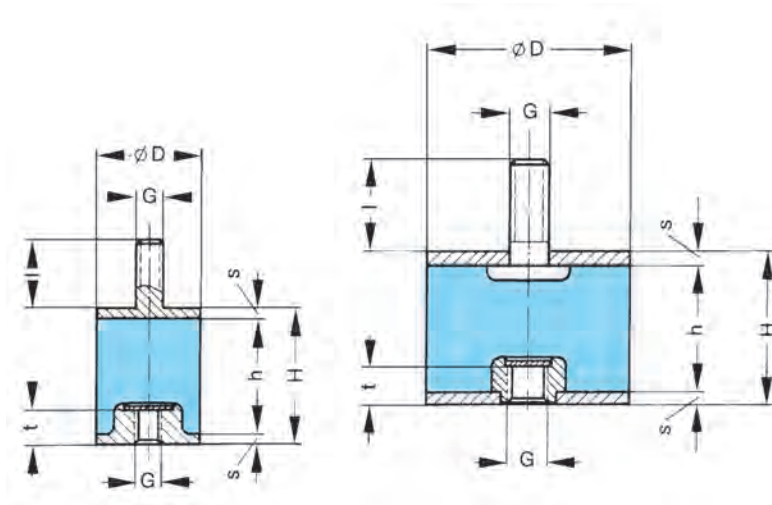

| Dimensions in mm | | | | | | | | Technical data | | | | | | | | | Number in Part No. package | | | |
|------------------|----|------|-------|------|------|------|---------------------------|--------------------|------|-------------------------------|--------|------|-------------------------------|--------------|------|-------------------------------|----------------------------|------|------------|-----|
| | | | | | | | | Compression stress | | | | | | Shear stress | | | | | | |
| D | H | h | s | G | l | t | Spring rate c_z in N/mm | | | Perm. load $F_{Perm.}^*$ in N | | | Spring rate $c_{x,y}$ in N/mm | | | Perm. load $F_{Perm.}^*$ in N | | | | |
| | | | | | | | hard | medium | soft | hard | medium | soft | hard | medium | soft | hard | medium | soft | | |
| 20 | 25 | 21,5 | 2/1,5 | M 6 | 16 | 6,5 | 140 | 80 | 50 | 290 | 180 | 100 | 27 | 17 | 10 | 140 | 90 | 50 | 781 057 | 100 |
| 25 | 20 | 16,5 | 2/1,5 | M 6 | 11 | 6,5 | 300 | 140 | 110 | 470 | 290 | 170 | 60 | 38 | 22 | 220 | 140 | 80 | 781 067 | 80 |
| 30 | 20 | 15,5 | 2,5/2 | M 8 | 13 | 6,5 | 650 | 410 | 240 | 900 | 560 | 330 | 110 | 70 | 40 | 370 | 230 | 140 | 781 079 | 60 |
| 30 | 20 | 14,5 | 2,5/3 | M 8 | 16 | 6,5 | 670 | 420 | 250 | 820 | 510 | 300 | 110 | 70 | 40 | 320 | 200 | 120 | 781 079 S1 | 60 |
| 30 | 30 | 24 | 3 | M 8 | 16 | 9,5 | 340 | 210 | 120 | 740 | 460 | 270 | 65 | 40 | 25 | 340 | 210 | 120 | 781 077 S3 | - |
| 30 | 30 | 24 | 3 | M 8 | 21 | 9,5 | 340 | 210 | 120 | 740 | 460 | 270 | 65 | 40 | 25 | 340 | 210 | 120 | 781 077 | 60 |
| 30 | 40 | 34 | 3 | M 8 | 21 | 9,5 | 180 | 110 | 60 | 660 | 410 | 240 | 32 | 20 | 12 | 290 | 180 | 100 | 781 078 | 60 |
| 40 | 30 | 24 | 3 | M 8 | 21 | 9,5 | 540 | 340 | 200 | 1200 | 740 | 440 | 100 | 60 | 35 | 510 | 320 | 190 | 781 087 | 40 |
| 40 | 40 | 34 | 3 | M 8 | 21 | 9,5 | 390 | 190 | 110 | 1150 | 700 | 410 | 90 | 40 | 25 | 580 | 360 | 210 | 781 088 | 40 |
| 50 | 40 | 34 | 3 | M10 | 18,5 | 10,5 | 550 | 350 | 210 | 2000 | 1240 | 730 | 110 | 65 | 35 | 900 | 560 | 330 | 781 097 S1 | - |
| 50 | 40 | 34 | 3 | M10 | 26,5 | 10,5 | 550 | 350 | 210 | 2000 | 1240 | 730 | 110 | 65 | 35 | 900 | 560 | 330 | 781 097 | 20 |
| 75 | 50 | 44 | 3 | M 12 | 39 | 12,5 | 930 | 600 | 310 | 4600 | 2850 | 1680 | 160 | 100 | 60 | 1850 | 1150 | 680 | 781 107 | 12 |
| 100 | 40 | 34 | 3 | M 16 | 44 | 16,5 | 3100 | 1600 | 1000 | 6700 | 4200 | 2500 | 400 | 220 | 120 | 2250 | 1400 | 820 | 781 117 | 4 |

* $F_{Perm.}$ is the permissible continuous static load upon which a fluctuating dynamic load can be superimposed. The permissible loads given represent only approximate guide values for the static load.

Stock items: Available only in standard packages.
 All items not marked in blue are listed in the catalogue and can be produced on request. Supply quantities on request.

Supply Programme MEGI® Buffer

Megi buffers with enlarged rubber-to-metal bonding surface

Part No. 781...

Versions: hard, medium, soft

Megi buffers with a “waisted” rubber section in relation to the bonding surface have good durability even at peak dynamic loads. Since the very dangerous peak stresses can be avoided at the edges of the bonding surfaces, these buffers are less affected by tensile stress than the normal cylindrical type of metal rubber buffers.

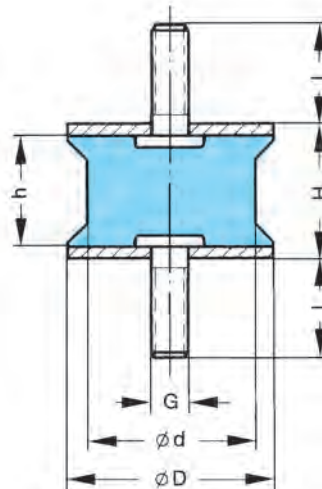

| Dimensions in mm | | | | | | | Technical data | | | | | | | | | | | | Number in package | |
|---------------------|----|----|----|---|------|------|---------------------------|--------|------|-------------------------------|--------|------|-------------------------------|--------|------|-------------------------------|--------|------|-------------------------|----|
| | | | | | | | Compression stress | | | | | | Shear stress | | | | | | | |
| D | d | H | h | s | G | l | Spring rate c_z in N/mm | | | Perm. load $F_{Perm.}^*$ in N | | | Spring rate $c_{x,y}$ in N/mm | | | Perm. load $F_{Perm.}^*$ in N | | | Part No. | |
| | | | | | | | hard | medium | soft | hard | medium | soft | hard | medium | soft | hard | medium | soft | | |
| 25,5 | 22 | 22 | 16 | 3 | M 8 | 21 | 320 | 200 | 120 | 770 | 480 | 280 | 60 | 35 | 20 | 320 | 200 | 120 | 781 146 | 60 |
| 40 | 35 | 28 | 22 | 3 | M 10 | 26,5 | 530 | 330 | 190 | 1740 | 1090 | 640 | 80 | 50 | 30 | 640 | 400 | 240 | 781 147 | 20 |
| 55 | 45 | 36 | 30 | 3 | M 10 | 22 | 600 | 370 | 250 | 2700 | 1670 | 1120 | 110 | 65 | 40 | 1100 | 650 | 400 | 781 145 | - |
| 60 | 50 | 60 | 54 | 3 | M 10 | 26,5 | 340 | 200 | 110 | 2590 | 1620 | 950 | 60 | 35 | 20 | 110 | 690 | 400 | 781 150 S1 | 8 |
| 80 | 70 | 70 | 64 | 3 | M 14 | 37 | 540 | 340 | 200 | 5220 | 3260 | 1920 | 100 | 60 | 35 | 2240 | 1400 | 820 | 781 149 | 8 |

* $F_{Perm.}$ is the **permissible continuous static load** upon which a fluctuating dynamic load can be superimposed. The permissible loads given represent only approximate guide values for the static load.

Stock items: Available only in standard packages.

MEGI® Stop Buffers

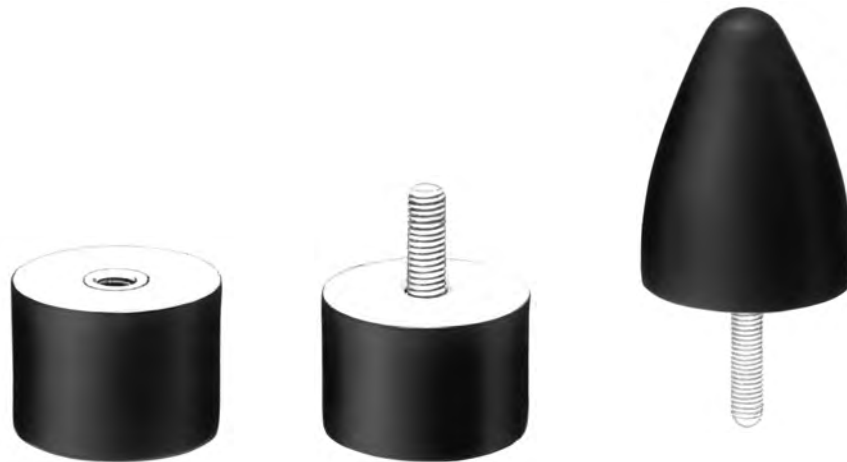

Applications

Megi are used to limit the effects of impact, e.g. in machines mounted on flexible bearings and as shock absorbers to limit the spring deflection in vehicles.

Megi are also used where machines, such as office machines are not anchored to the foundation or on sensitive floors. The larger versions such as the Megi fender buffers, are used for heavy and very heavy shock stresses, where it is necessary to absorb extremely high impact energy.

Description

Megi are in principle only subjected to compressive loads. When fitting the Megi, it is necessary to ensure that the components cannot move horizontally to the direction of the compressive load. Otherwise, the abrasion will lead to increased wear:

The different versions, e.g. with threaded studs, female thread or flange mounts, ensures good mounting possibilities for nearly every type of application. These parts are zinc coated and colourless passivated.

Technical Data

Megi cover a load spectrum up to **50 kN** depending on the shape and size of the bumper. Details are given in the tables. The maximum tightening torque for the central threaded mount can be chosen in conformance with strength class 5.

Delivery

Depending on the item, the Megi buffers are available from stock in standard packages or as catalogue goods producible on short notice.



MEGI® = METALLGUMMI® (Rubber Metal)
Registered trademark.

Supply Programme MEGI® Stop Buffers

Megi buffers with threaded stud Part No. 781...

| Dimensions in mm | | | | | | | Compression stress | | Number in package | |
|------------------|------|------|---|------|------|----------------------------------|--------------------------------------|---------|-------------------|--|
| D | H | h | s | G | l | Spring rate c_2 in N/mm medium | Perm. load $F_{Perm.}^*$ in N medium | | | |
| 18 | 7,5 | 5,5 | 2 | M 6 | 16 | 350 | 240 | 781 043 | 100 | |
| 20 | 13,5 | 11,5 | 2 | M 6 | 16 | 150 | 260 | 781 053 | 100 | |
| 25 | 17 | 14 | 3 | M 6 | 16 | 180 | 380 | 781 063 | 100 | |
| 30 | 17 | 14 | 3 | M 8 | 21 | 360 | 760 | 781 073 | 60 | |
| 40 | 27 | 24 | 3 | M 8 | 21 | 270 | 970 | 781 083 | 50 | |
| 50 | 21 | 18 | 3 | M 10 | 26,5 | 650 | 1760 | 781 093 | 20 | |
| 75 | 25 | 22 | 3 | M 12 | 39 | 1400 | 4620 | 781 103 | 8 | |
| 100 | 40 | 37 | 3 | M 16 | 44 | 1400 | 7770 | 781 113 | 4 | |

Megi stop bumper with female threads Part No. 781...

| Dimensions in mm | | | | | | | Compression stress | | Number in package | |
|------------------|------|----|-----|------|------|----------------------------------|--------------------------------------|---------|-------------------|--|
| D | H | h | s | G | t | Spring rate c_2 in N/mm medium | Perm. load $F_{Perm.}^*$ in N medium | | | |
| 20 | 13,5 | 12 | 1,5 | M 6 | 6,5 | 220 | 230 | 781 056 | 100 | |
| 30 | 17 | 14 | 3 | M 8 | 9,5 | 550 | 620 | 781 076 | 80 | |
| 40 | 27 | 24 | 3 | M 8 | 9,5 | 350 | 920 | 781 086 | 40 | |
| 50 | 21 | 18 | 3 | M 10 | 10,5 | 700 | 1100 | 781 096 | 20 | |
| 75 | 25 | 22 | 3 | M 12 | 12,5 | 1700 | 3200 | 781 106 | 20 | |
| 100 | 40 | 37 | 3 | M 16 | 16,5 | 1400 | 4950 | 781 116 | 12 | |
| 200 | 100 | 95 | 5 | M 20 | 17,5 | 1700 | 21000 | 781 136 | - | |

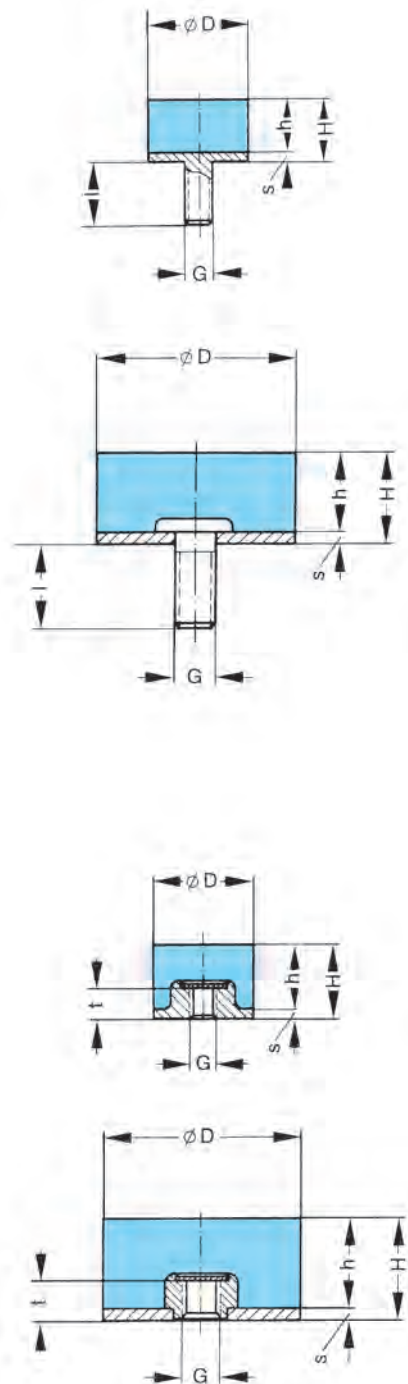

Stock items. Can be supplied in standard packages in "medium" hardness, approx. 60° shore. Other types produced to order.

All items not marked in blue are listed in the catalogue and can be produced on request. Supply quantities on request.

Supply Programme MEGI® Stop Buffers

Megi with parabolic cross-section

The special design of Megi with their parabolic cross-section allows them to yield readily to initial impact while maintaining highly progressive spring characteristics. They can be used as shock absorbers to limit the amplitude of vibration and spring deflection.

Part No. 741 279

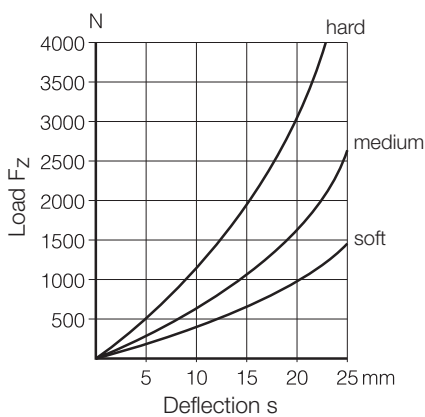
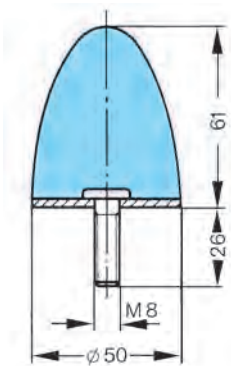

Part No. 741 280

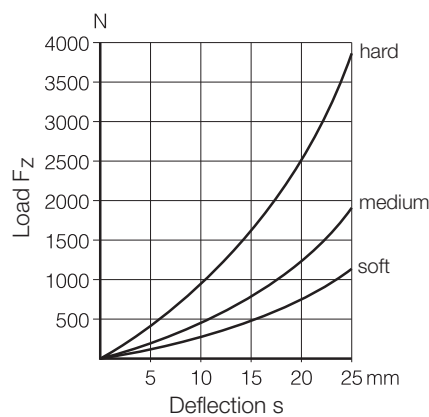
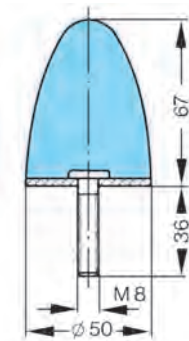

Part No. 741 278

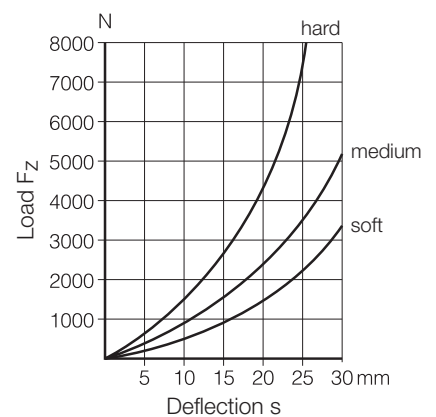
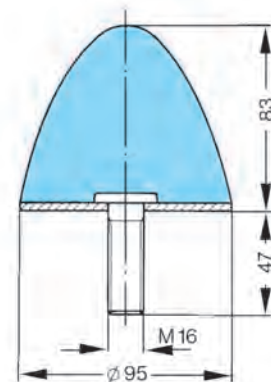

Stock items. Can be supplied in standard packages in “medium” hardness, approx. 60° shore. Only available in packages of 10.

Other types produced to order.

MEGI® Bars

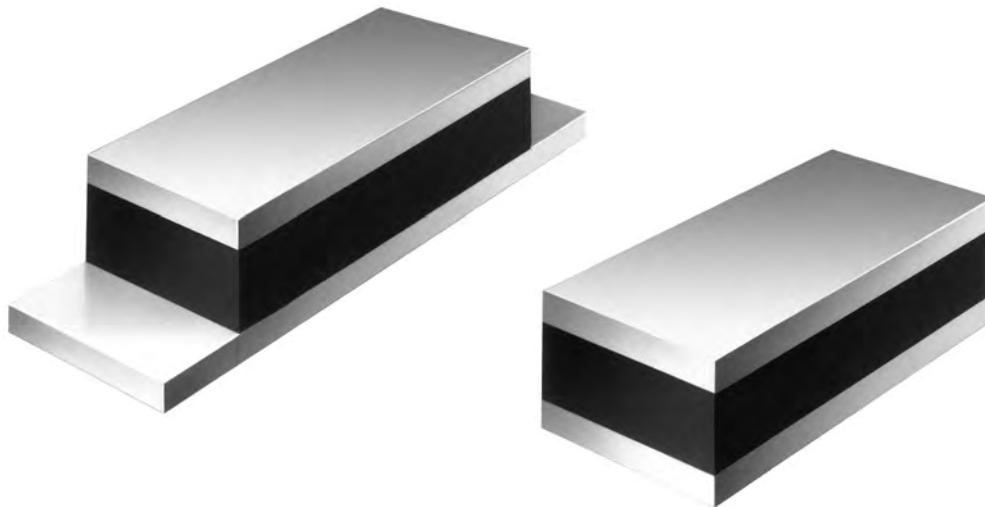

Applications

Megi bars are especially suitable for flexible bearing arrangements for heavy machines such as, for example, marine engines, large stationary engines, lathes, hoisting engines, jogging and vibrating machines. Megi bars can be used anywhere the available space and high loads do not allow installation of buffers.

Description

Megi bars are produced in lengths from 500 to 2000 mm and can be cut to any desired length. However, it is necessary to ensure that the minimum length does not exceed the sectional width. The thickness of the metal plate must be selected so that threaded holes can be tapped in them for fastening purposes. Megi bars with

projecting base plate can only be supplied in the fixed lengths indicated in the table. Under static load, the rubber thickness "h" can be compressed by approx. 10 to 15%. 10% for $h < 40$ mm, 15% for $h > 40$ mm. Megi bars are installed primarily to absorb compressive stress or are set at an angle to each other to absorb compressive and shearing stress.

Technical Data

Megi bars cover a load spectrum up to 775 kN depending on the bar section and length. Further details are given in the tables.



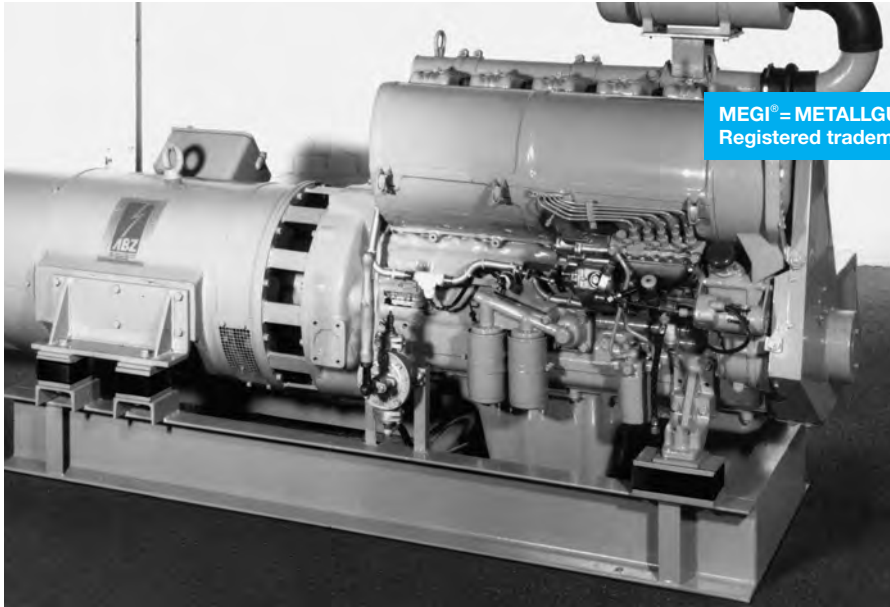

MEGI® = METALLGUMMI® (Rubber Metal)
Registered trademark.

Supply Programme MEGI® Bars

Megi Bars

For large orders, metal-rubber bars can be supplied with metal plates of a different thickness “s” and with a thinner rubber layer.

Metal rubber bars can also be supplied as impact plates, that is with a metal plate on one side only to meet special production orders.

DIN 1017 applies for metal parts.

The appropriate thickness tolerances for Megi bars are given in DIN ISO 3302 - M3.

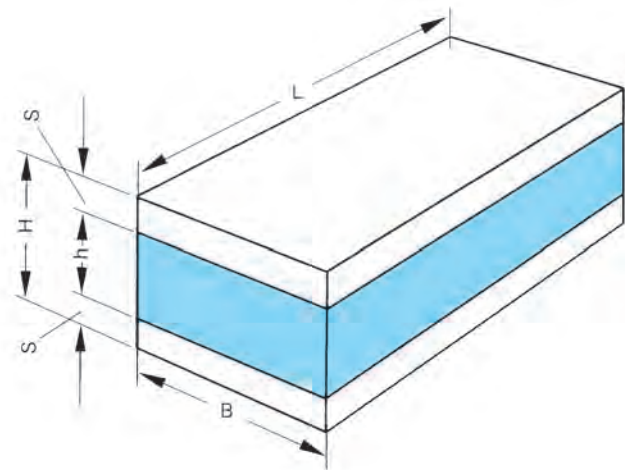

| B | H | h | s | Available in lengths of | Part No. |
|----|----|----|----|-------------------------|----------|
| 20 | 30 | 20 | 5 | 500 mm | 781 210 |
| 25 | 30 | 20 | 5 | 500 mm | 781 211 |
| 40 | 35 | 19 | 8 | 500 mm | 781 212 |
| 50 | 40 | 20 | 10 | 2000 mm | 781 314 |
| 50 | 50 | 30 | 10 | 2000 mm | 781 315 |

| B | H | h | s | Available in lengths of | Part No. |
|-----|----|----|----|-------------------------|----------|
| 60 | 60 | 40 | 10 | 2000 mm | 781 324 |
| 70 | 50 | 30 | 10 | 2000 mm | 781 330 |
| 100 | 60 | 30 | 15 | 2000 mm | 781 333 |
| 100 | 80 | 50 | 15 | 2000 mm | 781 334 |
| 150 | 65 | 35 | 15 | 2000 mm | 781 338 |
| 150 | 80 | 50 | 15 | 2000 mm | 781 339 |

Spring rate for compression stress c_D

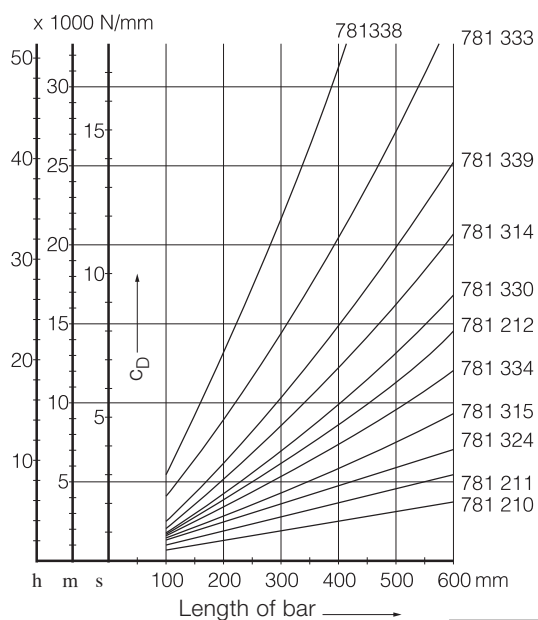

Spring rate for compression stress c_S

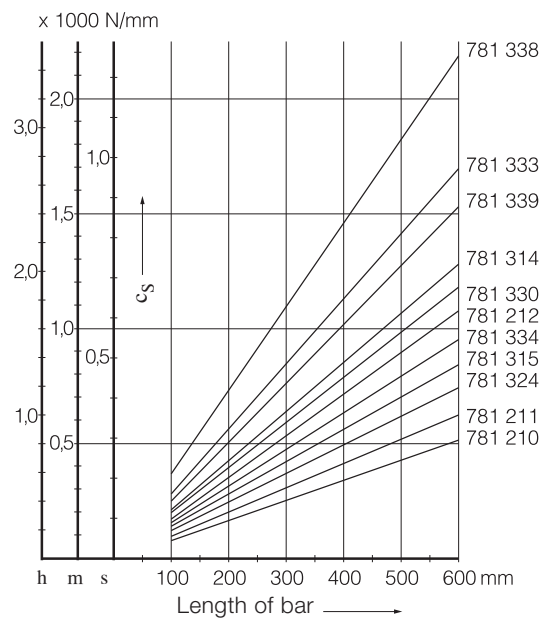

Stock items. Can be supplied in standard packages in “medium” hardness, approx. 60° shore. Only available in packages of 10. No standard packages.

All items not marked in blue are listed in the catalogue and can be produced on request. Supply quantities on request.

Supply Programme MEGI® Bars

Megi bars with extending base plate

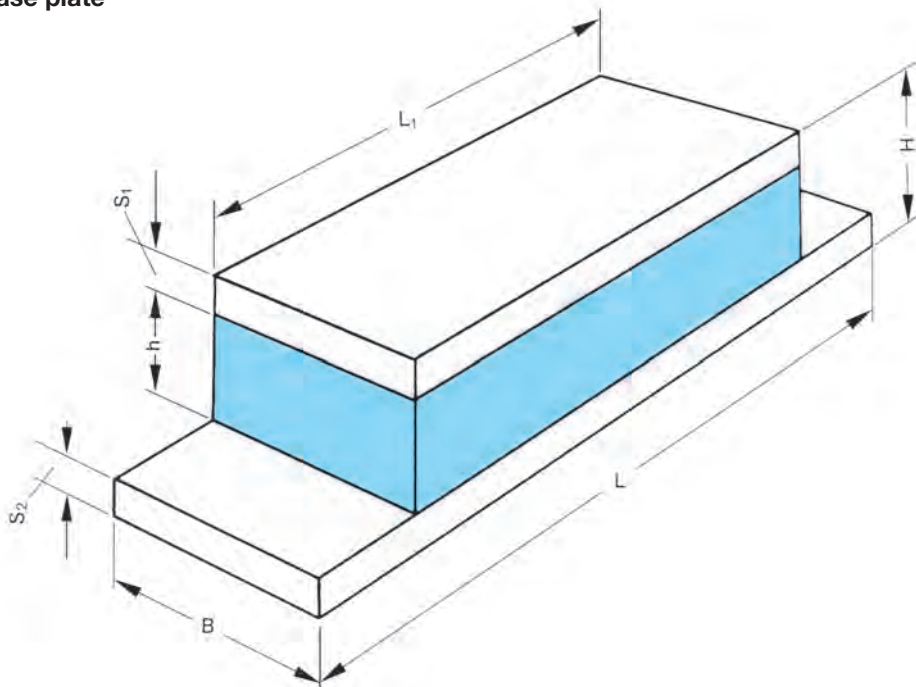

| Dimensions in mm | | | | | | | Technical data | | | | | | | | | Part No. | | | |
|---------------------|----|----|----------------|----------------|-----|----------------|------------------------------------|--------|-------|---------------------------------------|--------|------|------------------------------------|--------|------|----------|---------------------------------------|------|---------|
| | | | | | | | Compression stress | | | | | | Shear stress | | | | | | |
| B | H | h | S ₁ | S ₂ | L | L ₁ | Spring rate c _D in N/mm | | | Perm. load F _{Perm.} * in kN | | | Spring rate c _S in N/mm | | | | Perm. load F _{Perm.} * in kN | | |
| | | | | | | | hard | medium | soft | hard | medium | soft | hard | medium | soft | hard | medium | soft | |
| 50 | 40 | 20 | 12 | 8 | 200 | 150 | 6500 | 4000 | 2300 | 13 | 8 | 5 | 500 | 300 | 200 | 2,5 | 1,5 | 1 | 711 023 |
| 50 | 40 | 20 | 12 | 8 | 270 | 220 | 11400 | 7100 | 4000 | 24 | 15 | 9 | 750 | 500 | 300 | 3,5 | 2 | 1,5 | 711 025 |
| 100 | 60 | 30 | 15 | 15 | 480 | 360 | 29000 | 18200 | 10400 | 94 | 59 | 35 | 1700 | 1000 | 600 | 11,5 | 7 | 4 | 711 019 |

* F_{Perm.} is the **permissible continuous static load** upon which a fluctuating dynamic load can be superimposed. If the Megi bars are subjected to shearing stress, it is essential to avoid tensile stress on the rubber during installation of the Megi bars. In order to obtain an adequate service life, the bars should be pretensioned.

Stock items. Delivered in “medium” hardness, approx. 60° shore.

All items not marked in blue are listed in the catalogue and can be produced on request. Supply quantities on request.

MEGI® Machine Mounts



Application

■ MEGI Machine Mounts are proven universal elements for resilient support of machines of all types. MEGI Machine Mounts are preferred wherever it is necessary to avoid great horizontal motions (e.g. machine tool instability). Their horizontal rigidity is greater than the vertical rigidity in all directions. When used properly, MEGI Machine Mounts are excellent to prevent transfer of shocks and noises.

■ MEGI Machine Mounts can also be supplied with a height adjustment allowing the equipment to be levelled.

■ MEGI Machine Mounts with tear-off protection specially withstand 3 g in all directions. When such load occurs, it's necessary to replace the part. These tear-off proof Machine Mounts are the ideal spring elements for special applications where tension forces are expected (e.g. in vehicle and marine construction). These articles are zinc coated and Cr6-free passivated.

Description

MEGI Machine Mounts are supplied with rectangular or oval flange. The versions with height adjustment allow the resiliently supported equipment to be levelled. MEGI Machine Mounts are distinguished by their low overall height. These parts are zinc coated and colourless passivated.

Technical Data

The MEGI Machine Mounts cover a load spectrum **up to 21 kN** depending on the size of the Machine Mounts and type of rubber used. Further information is given in the tables.

The maximum tightening torques for the central threaded mounts can be selected in conformance with strength class 5.

Use for resilient support of:

- Engines of all types,
- Diesel assemblies,
- Machine tools,
- Eccentric presses,
- Textile machines,
- Wood processing machines,
- Printing presses,



- Sieves,
- Rolling mills,
- Pumps,
- Ventilation equipment, etc.
- Washing machines.

Delivery

Available from stock in standard packages.

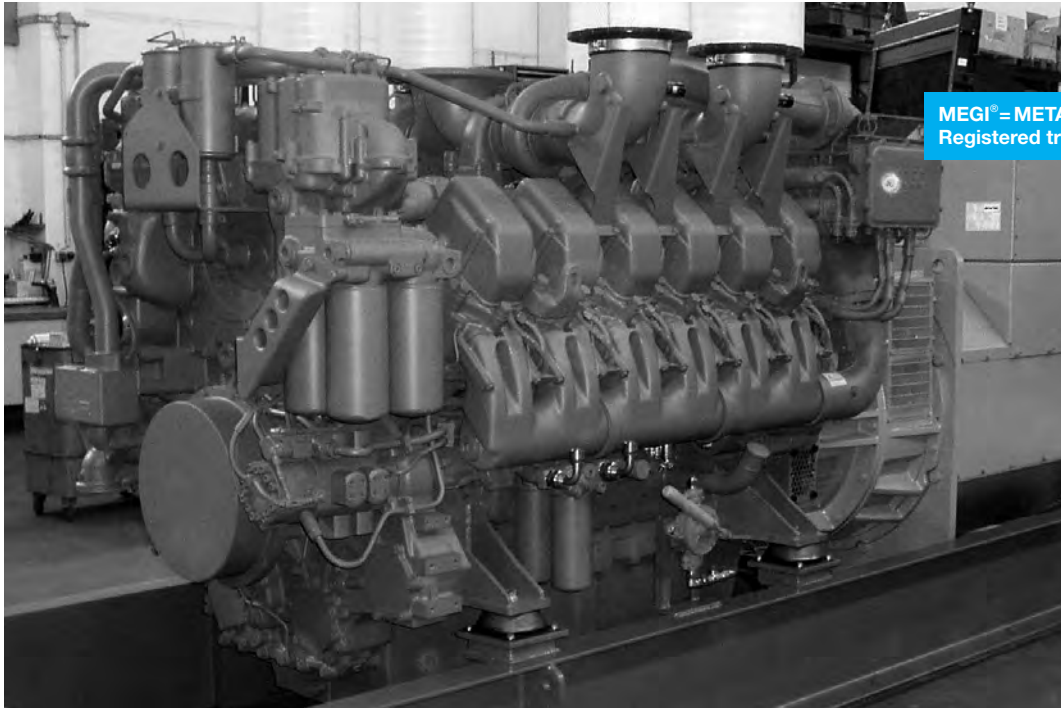

MEGi® = METALLGUMMI® (Rubber Metal)
Registered trademark.

Supply Programme MEGI® Machine Mounts

Megi Machine Mounts

Part No. 786 010

Versions:

hard, medium, soft

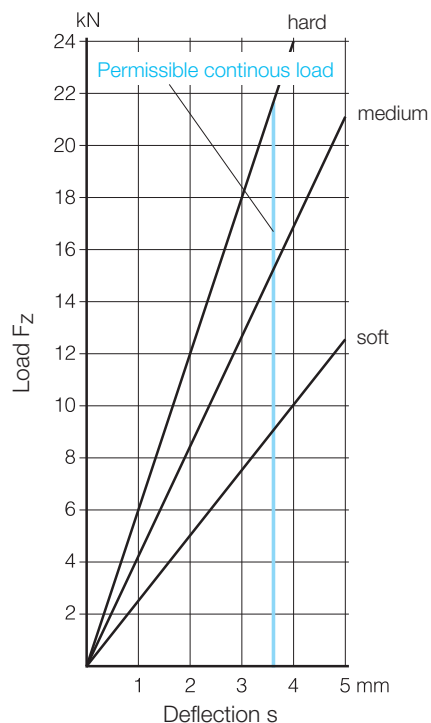
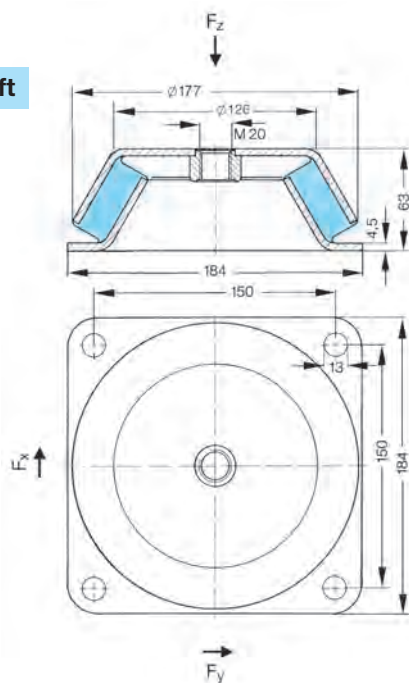

Megi Machine Mounts with height adjustment

Part No. 786 110

Versions:

hard, medium, soft

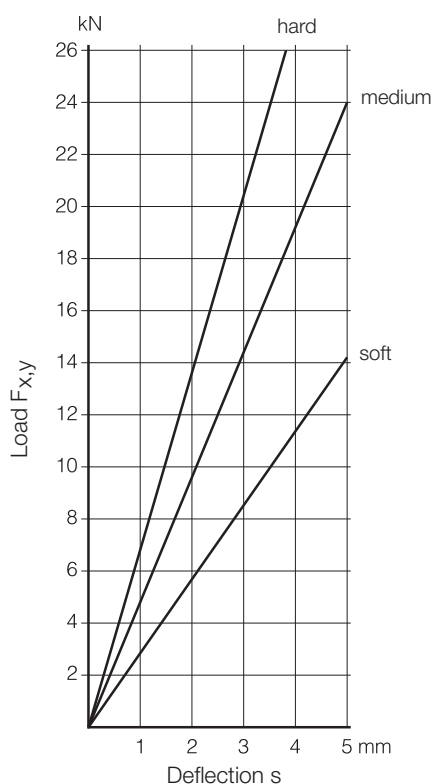
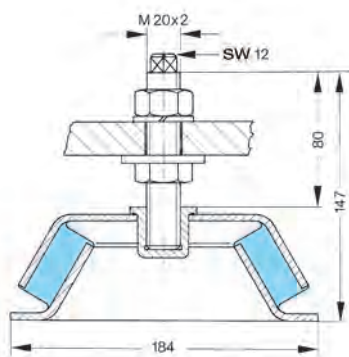

Megi Machine Mounts with tear-off protection

Part No. 786 210

Versions:

hard, medium, soft

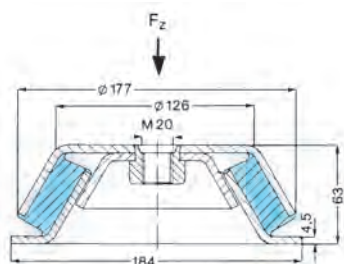

Stock items.
Available only in packages of 4 each.

Supply Programme MEGI® Machine Mounts

Megi Machine Mounts

Part No. 786 011

Versions:

hard, medium, soft

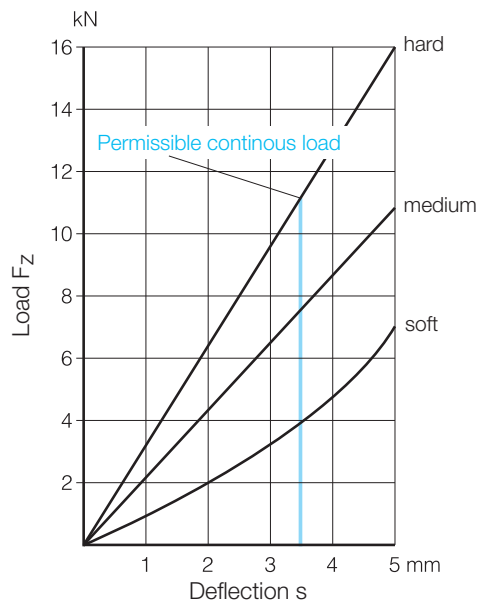
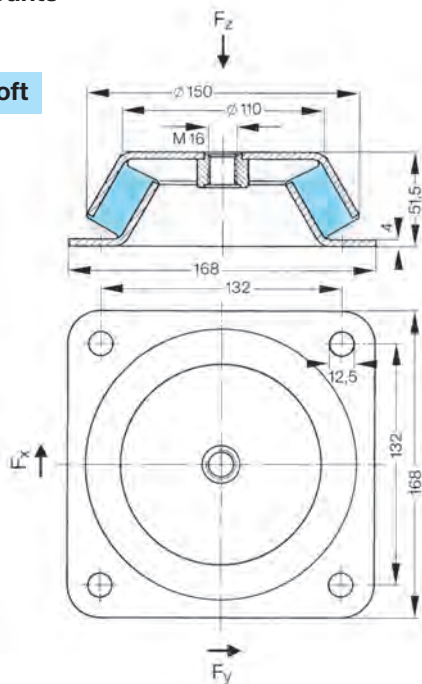

Megi Machine Mounts with height adjustment

Part No. 786 111

Versions:

hard, medium, soft

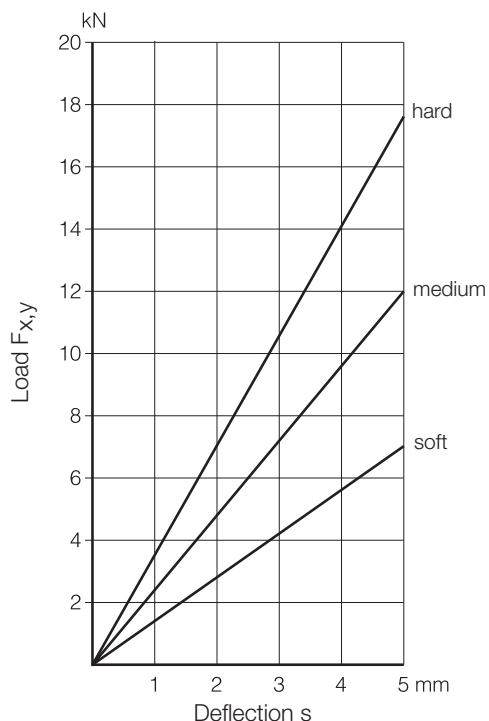
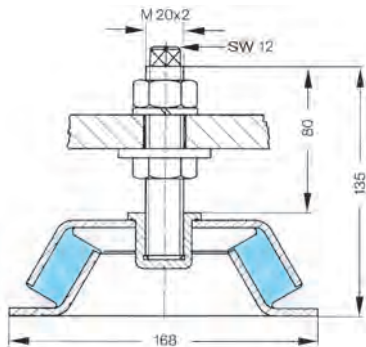

Megi Machine Mounts with tear-off protection

Part No. 786 211

Versions:

hard, medium, soft

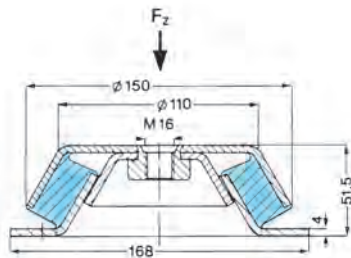

Stock items.

Available only in packages of 4 each.

Supply Programme MEGI® Machine Mounts

Megi Machine Mounts

Part No. 786 013

Versions:

hard, medium, soft

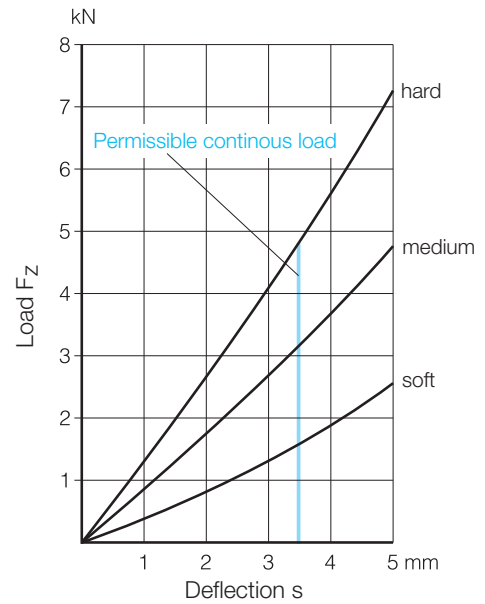
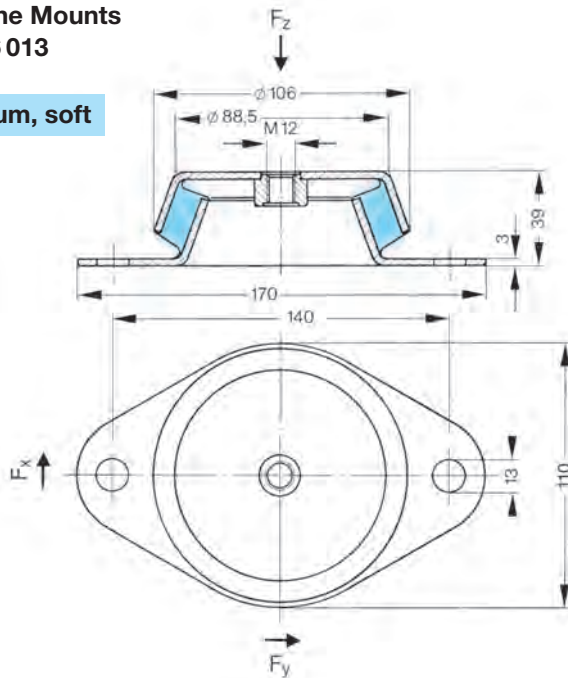

Megi Machine Mounts with height adjustment

Part No. 786 113

Versions:

hard, medium, soft

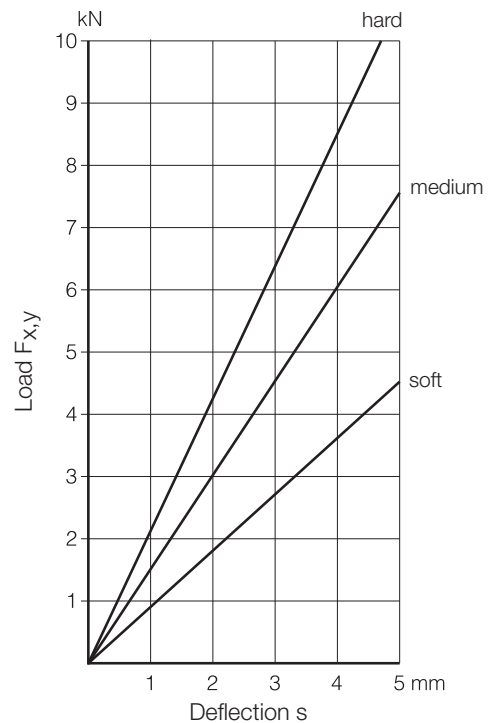
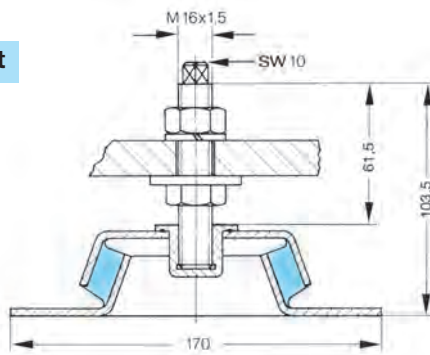

Megi Machine Mounts with tear-off protection

Part No. 786 213

Versions:

hard, medium, soft

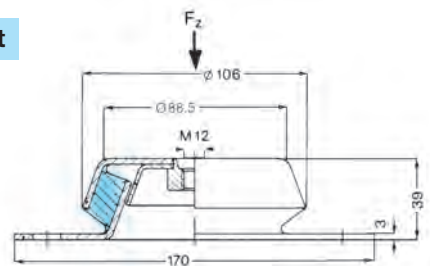

Stock items.
Available only in packages of 8 each.

Supply Programme MEGI® Machine Mounts

Megi Machine Mounts

Part No. 786 014

Versions:

hard, medium, soft

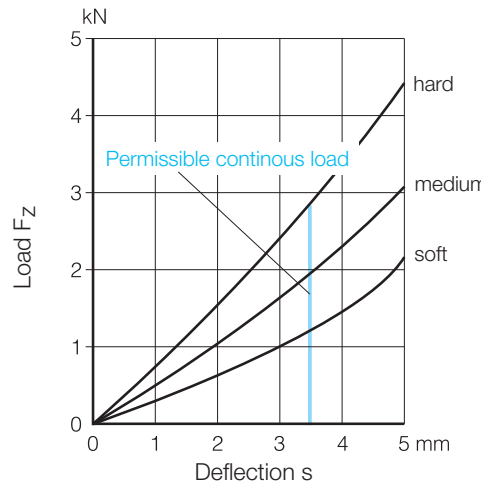
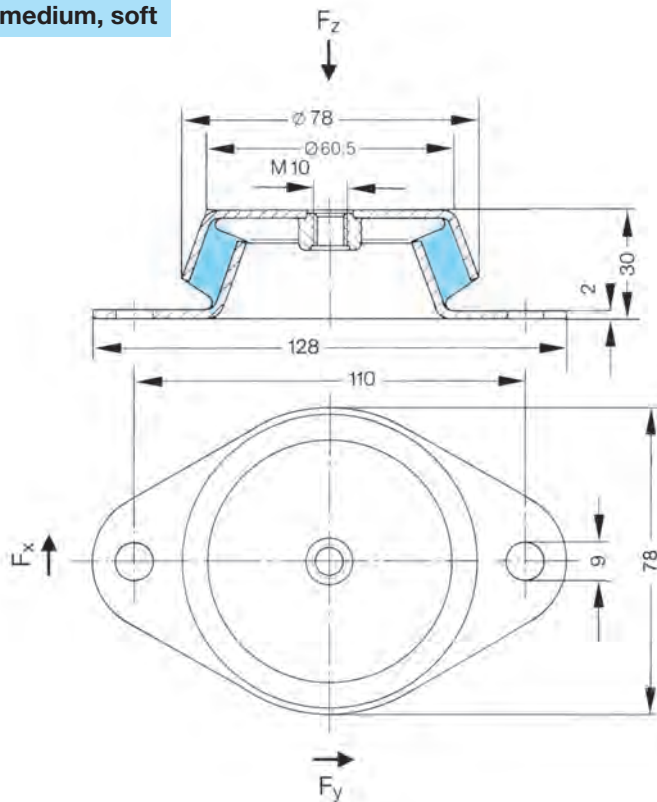

Megi Machine Mounts with tear-off protection

Part No. 786 214

Versions:

hard, medium, soft

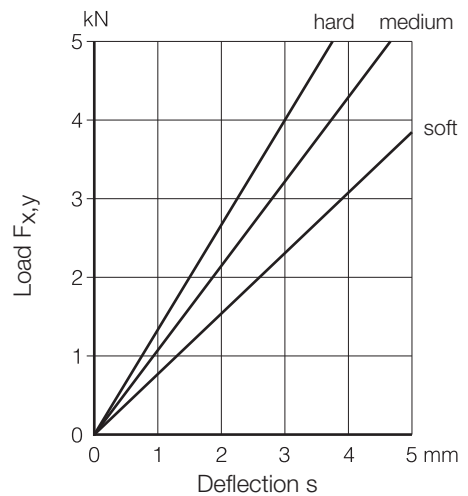
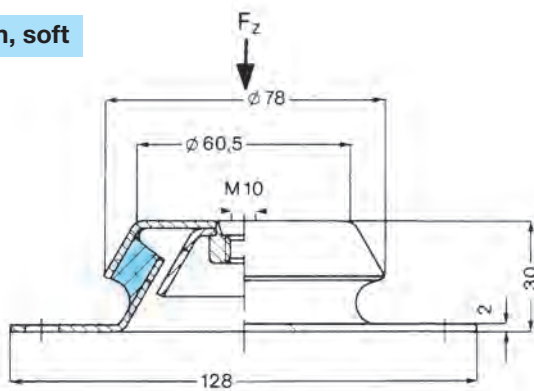

Stock items.
Available only in packages of 8 each.

Supply Programme MEGI® Machine Mounts

Megi Machine Mounts with tear-off protection

| Part No. | Compressive load | | Dimensions in mm | | | | | | | | Max. tightening torque |
|------------|-----------------------------|------------------------|------------------|-----|-----|------|----|-----|-----|-----|------------------------|
| | C_z in N/mm $\pm 20\%$ | max. load F_z [N] | D | L1 | L | H | d | s | G | B | M_{anz} [Nm] |
| 786 230 | 315 | 950 | 79 | 110 | 130 | 30 | 9 | 3 | M10 | 79 | 50 |
| 786 230 S1 | 680 | 1900 | 79 | 110 | 130 | 30 | 9 | 3 | M10 | 79 | 50 |
| 786 231 | 235 | 1500 | 82 | 110 | 135 | 35,5 | 11 | 2,5 | M10 | 89 | 50 |
| 786 232 | 475 | 1800 | 94 | 124 | 150 | 35 | 10 | 3,5 | M10 | 100 | 50 |
| 786 232 S1 | 1000 | 2700 | 94 | 124 | 150 | 35 | 10 | 3,5 | M10 | 100 | 50 |
| 786 233 | 570 | 2500 | 101 | 144 | 175 | 38 | 14 | 3,5 | M16 | 105 | 210 |
| 786 233 S1 | 1215 | 4500 | 101 | 144 | 175 | 38 | 14 | 3,5 | M16 | 105 | 210 |
| 786 234 | 860 | 4000 | 123 | 158 | 192 | 42 | 14 | 4 | M16 | 130 | 210 |
| 786 234 S1 | 1285 | 6000 | 123 | 158 | 192 | 42 | 14 | 4 | M16 | 130 | 210 |
| 786 236 | 1150 | 7500 | 144 | 182 | 216 | 48 | 14 | 4 | M16 | 144 | 210 |
| 786 236 S1 | 2150 | 13000 | 144 | 182 | 216 | 48 | 14 | 4 | M16 | 144 | 210 |

The ratio of the vertical to horizontal rigidity is near to 1.
($C_z / C_{x/y} \approx 1$)

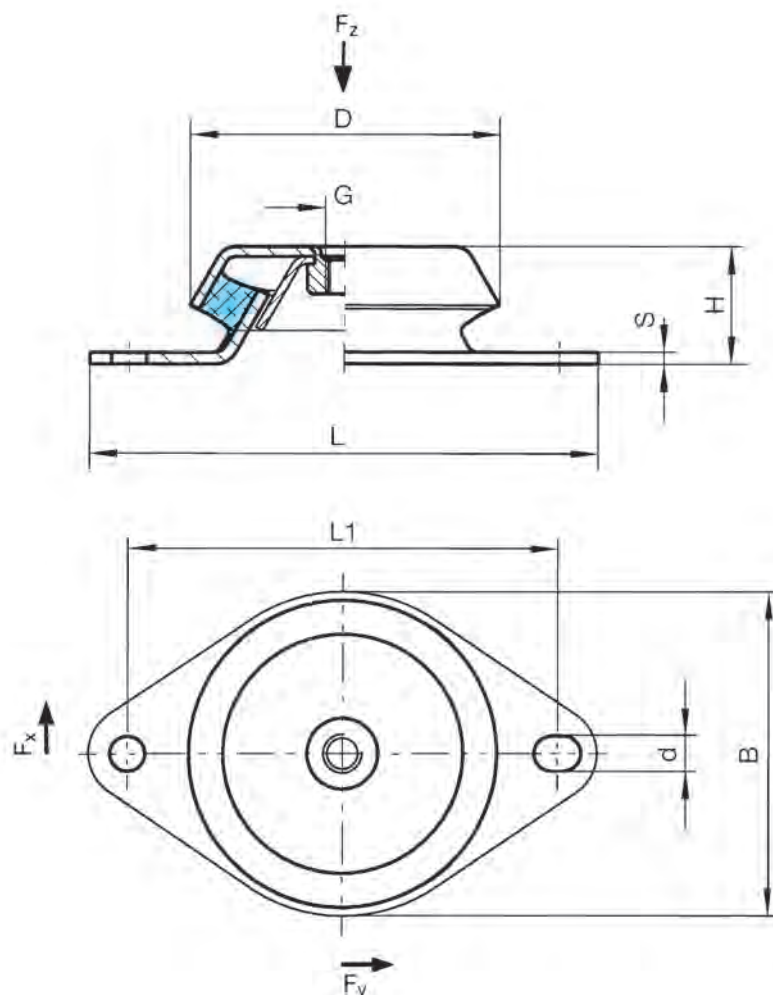



MEGI® = METALLGUMMI® (Rubber Metal)
Registered trademark.



MEGI®-Cones



Applications

Megi cones are ideal for oscillation damp, i.e. low vibration bearing arrangements for motors, body superstructures on chassis frames, compressor units on rail cars, etc. there are transfer recesses in the Megi cones used for piston engines so that the elasticity constant in the longitudinal direction differs from the value in the transverse direction.

Description

Megi cones consist of inner and outer metal cones. The outer cone has an oval or rectangular flange for mounting purposes. Stop plates are fitted in order to limit deformation under compression and tension. Where extremely high stress is present, these stop plates prevent separation of the cone components. Axial impact can be progressively absorbed by the upper stop plate, which, if compression force is excessive, rests on the upper rubber shoulder. If tensile forces are excessive, the inner cone can be deflected only until the bottom stop plate comes up against the lower collar of the outer cone. Megi cones are designed so that the springing effect is soft in the axial direction and very stiff in the radial direction. These parts are zinc coated and colourless passivated.

Technical Data

Megi cones cover a load spectrum **up to 17 kN** depending on the cone and type of rubber used. The spring values are given in the diagrams. The inner part of the cone may only be subjected to compression at the specified max. initial tension (inner parts with high strength available on

request). The upper washer has to be supported by the screwed part. The type of threaded mount and tightening torques must be selected accordingly.

Example:

M8 bolt, strength class 8.8, coefficient of friction $\mu_R = 0.15$ result in an initial tension force for the threaded connection of approx. 16 kN and a tightening torque of approx. 25 Nm.

Delivery

Depending on the item, the Megi buffers are available from stock in standard packages or as catalogue goods producible on short notice.



MEGI® = METALLGUMMI® (Rubber Metal)
Registered trademark.

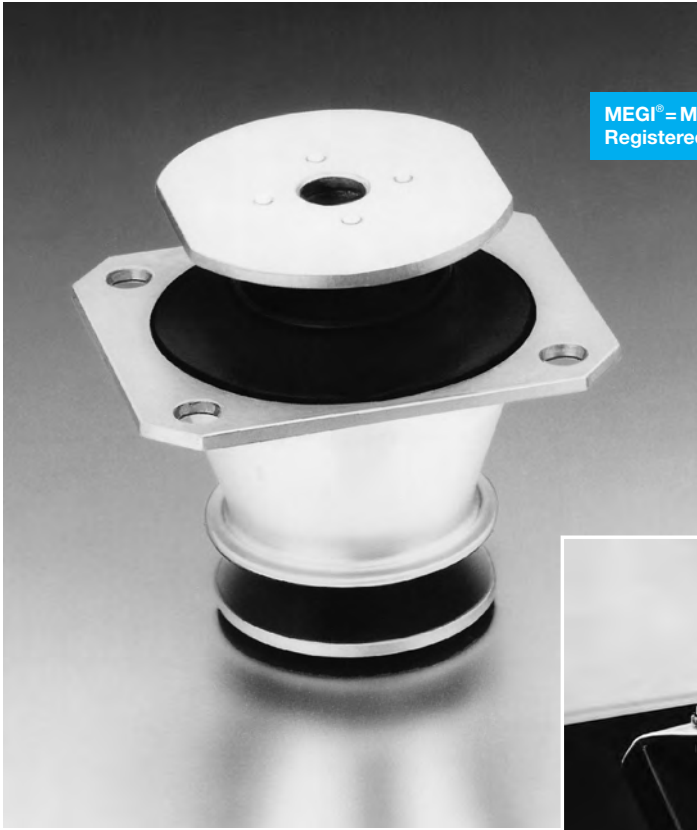

Supply Programme MEGI®-Cones

Megi cone
 Part No. 786 021
 Versions:
 hard, medium, soft

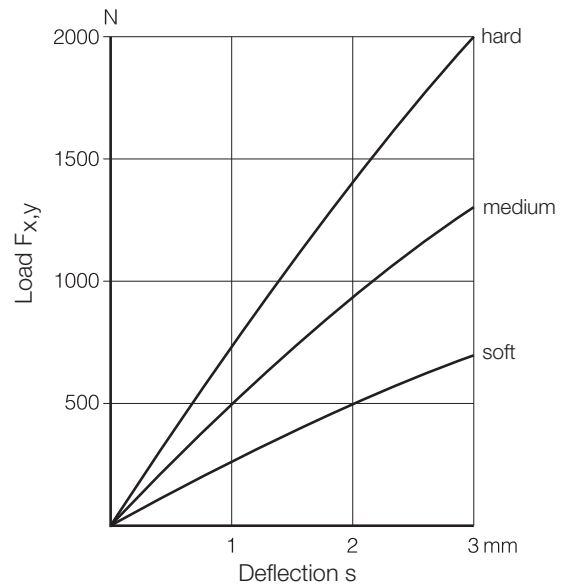
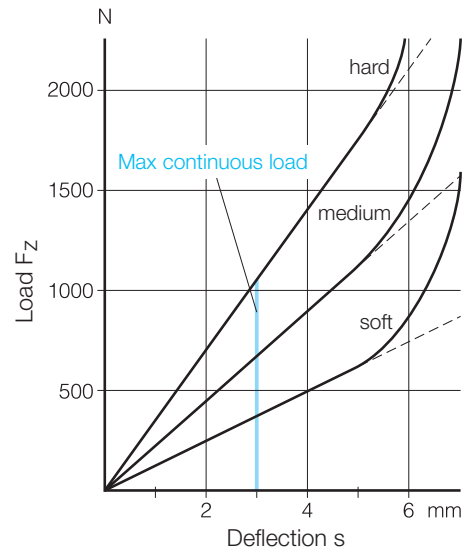
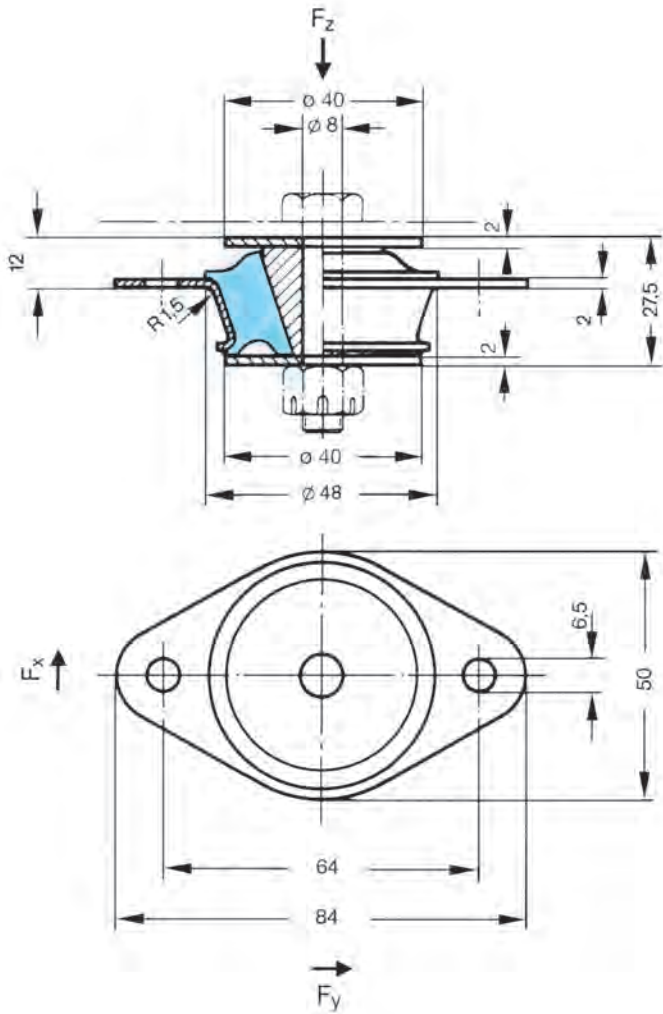

Stock items.
 Available only in packages of 16 each.

Max. tension force of central threaded mount on inner section of cone
 $F_v = 20$ kN.

Supply Programme MEGI®-Cones

Megi cone

Part No. 786 021 S1

Versions:

hard, medium, soft

Special version for use as piston engine bearings. These cones have transverse radial recesses so that they are much softer in the transverse direction than in the longitudinal direction.

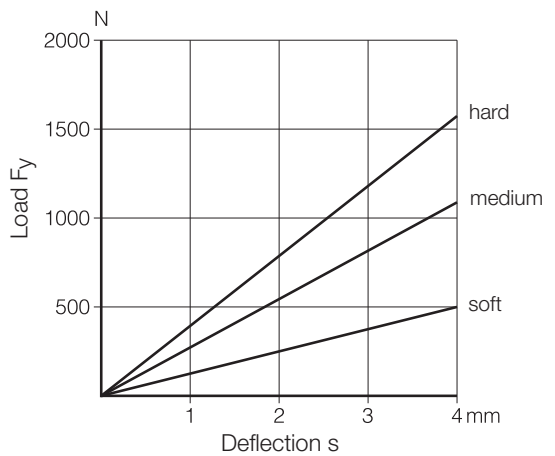
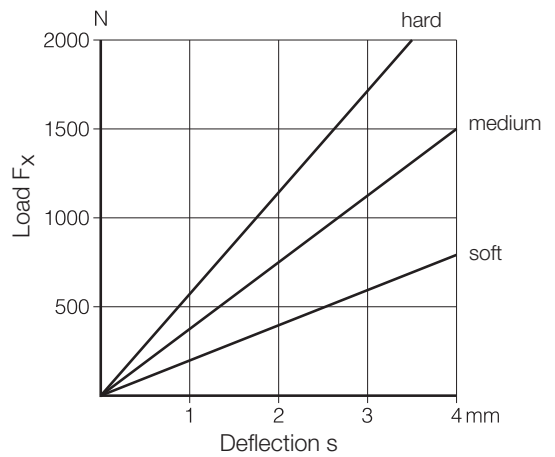
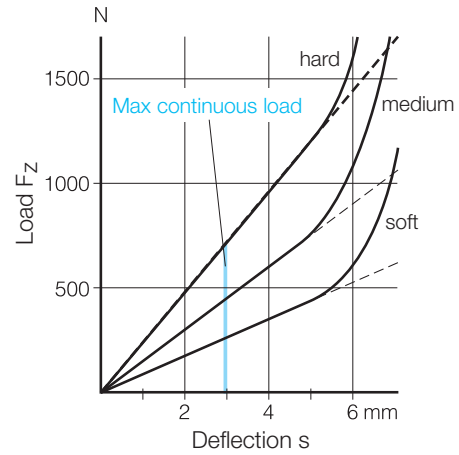
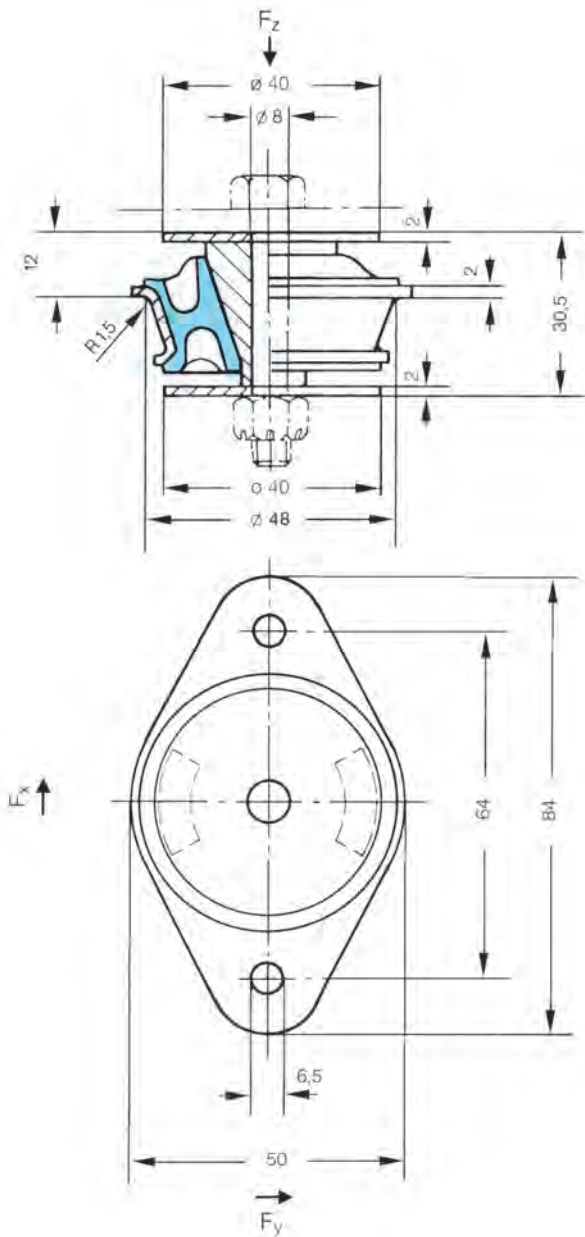

This item is listed in the catalogue and can be produced on request. Supply quantity on request.

Stock item. Available only in packages of 16 each.

Max. tension force of central threaded mount on inner section of cone $F_V = 20$ kN.

Supply Programme MEGI®-Cones

Megi cone
 Part No. 786 025
 Versions:
 hard, medium, soft

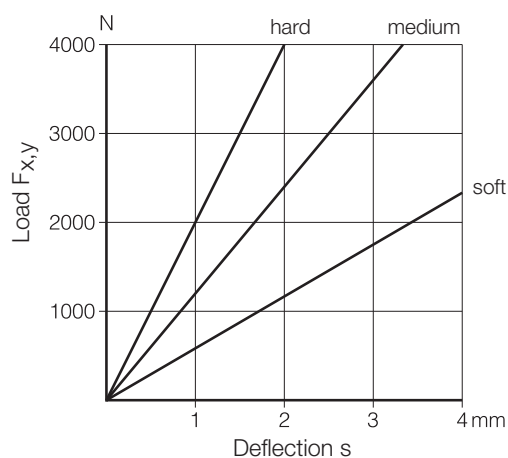
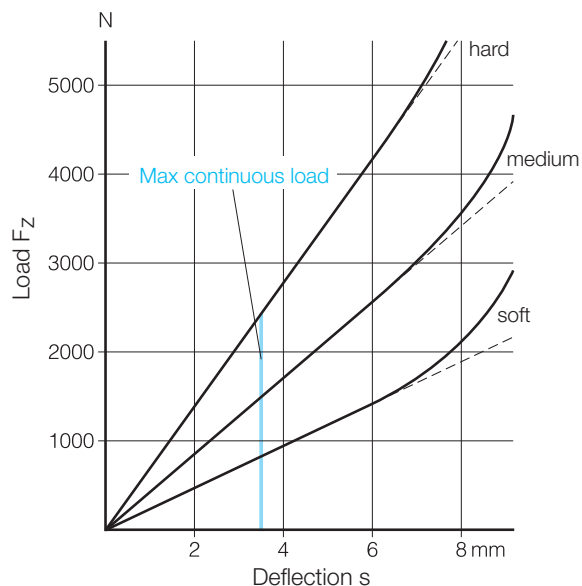
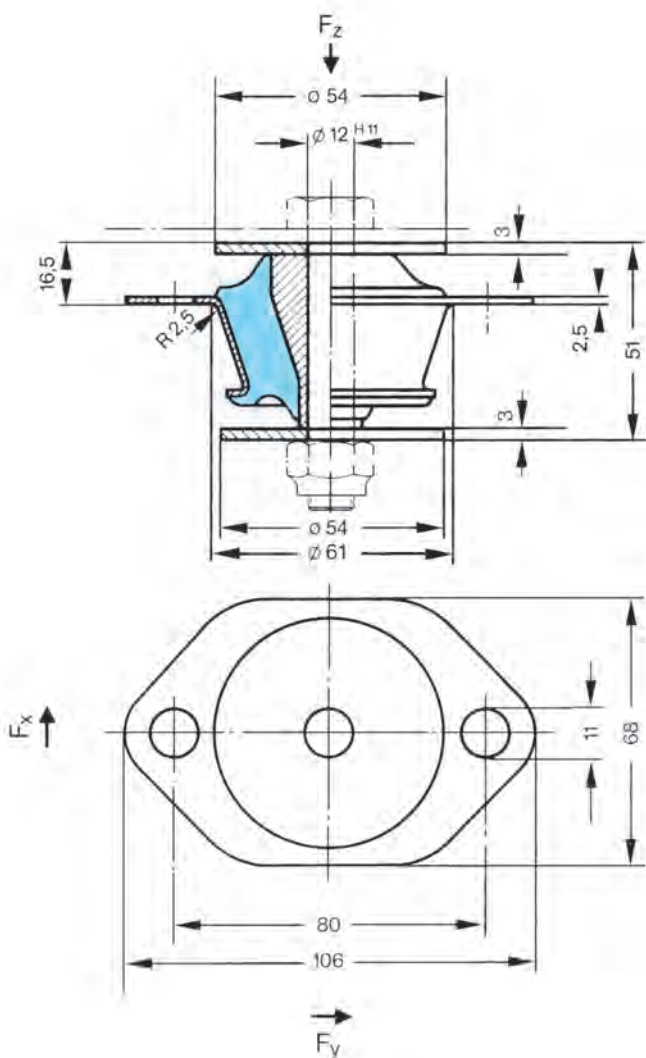

Stock item. Available only in packages of 8 each.

Max. tension force of central threaded mount on inner section of cone $F_v = 40$ kN.

Supply Programme MEGI®-Cones

Megi cone
Part No. 786 025 S1
Versions:
hard, medium, soft

Special version for use as piston engine bearings. These cones have transverse radial recesses so that they are much softer in the transverse direction than in the longitudinal direction.

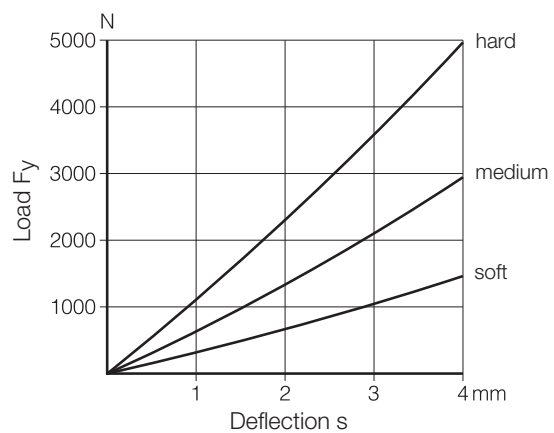
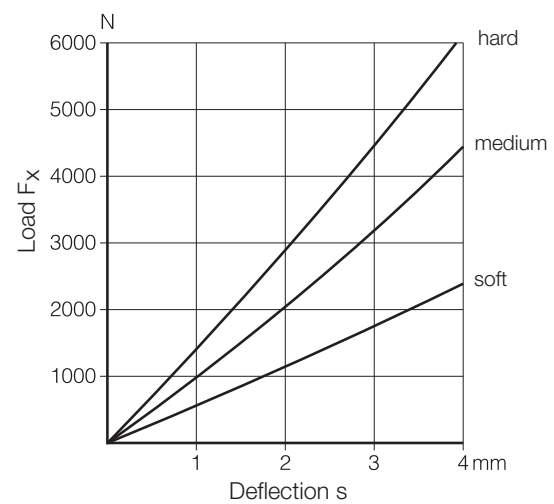
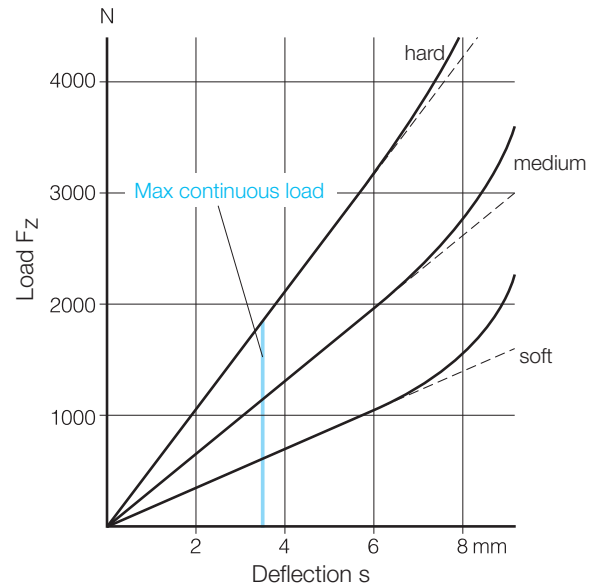
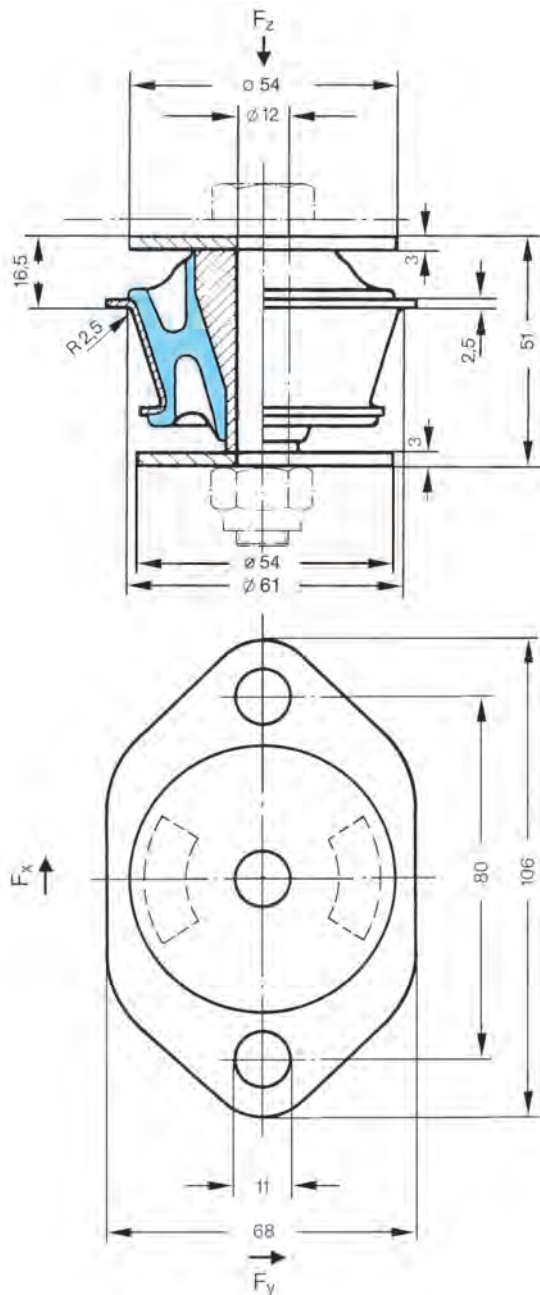

This item is listed in the catalogue and can be produced on request. Supply quantity on request.

Max. tension force of central threaded mount on inner section of cone
 $F_V = 40$ kN.

Supply Programme MEGI®-Cones

Megi cone
Part No. 786 026 S1
Versions:

hard, medium, soft

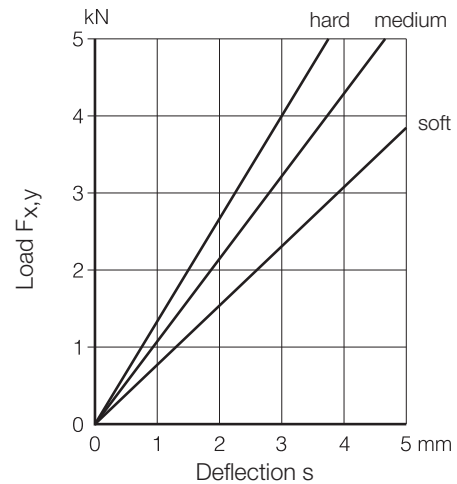
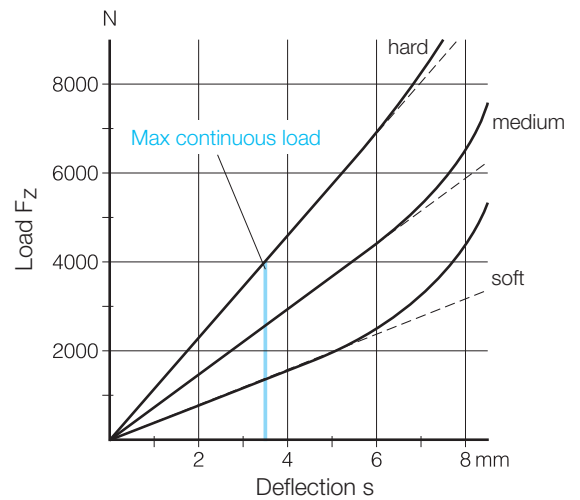
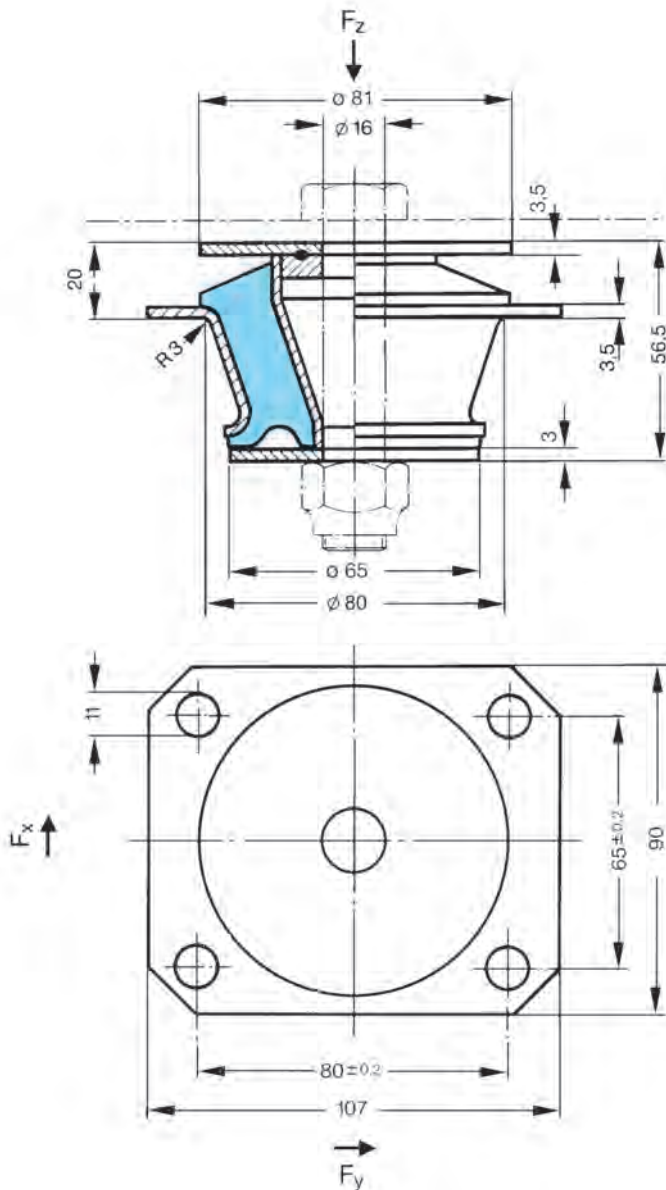

Stock item. Available only in packages of 4 each.

Max. tension force of central threaded mount on inner section of cone $F_V = 50$ kN.

Supply Programme MEGI®-Cones

Megi cone
Part No. 786 026 S3
Versions:
hard, medium, soft

Special version for use as piston engine bearings.
 These cones have transverse radial recesses so that they are much softer in the transverse direction than in the longitudinal direction.

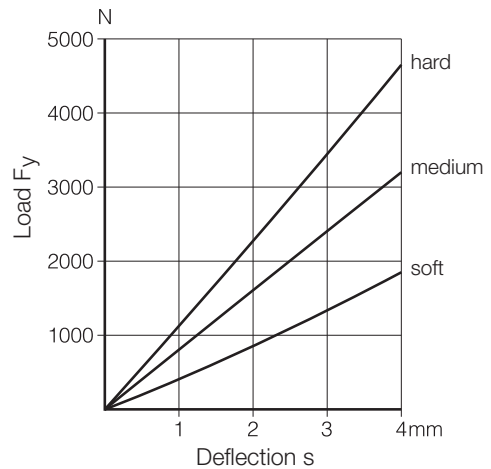
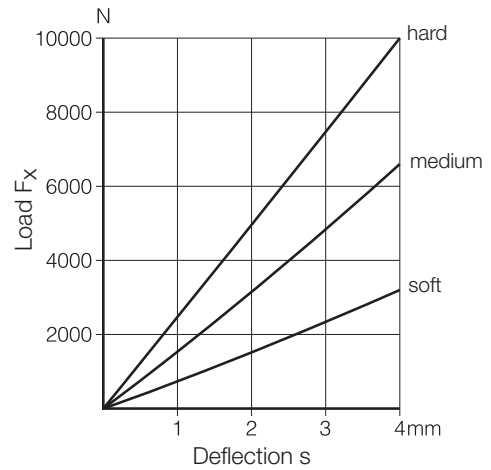
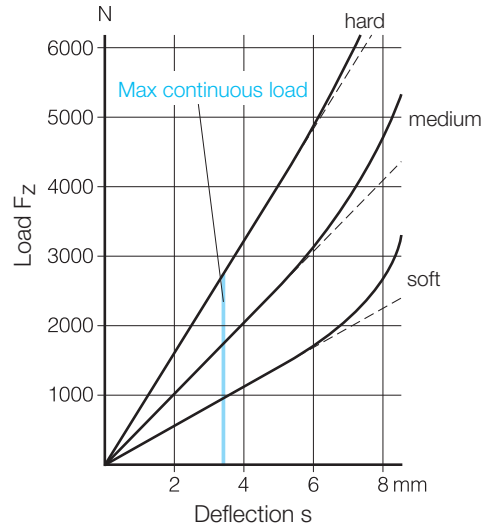
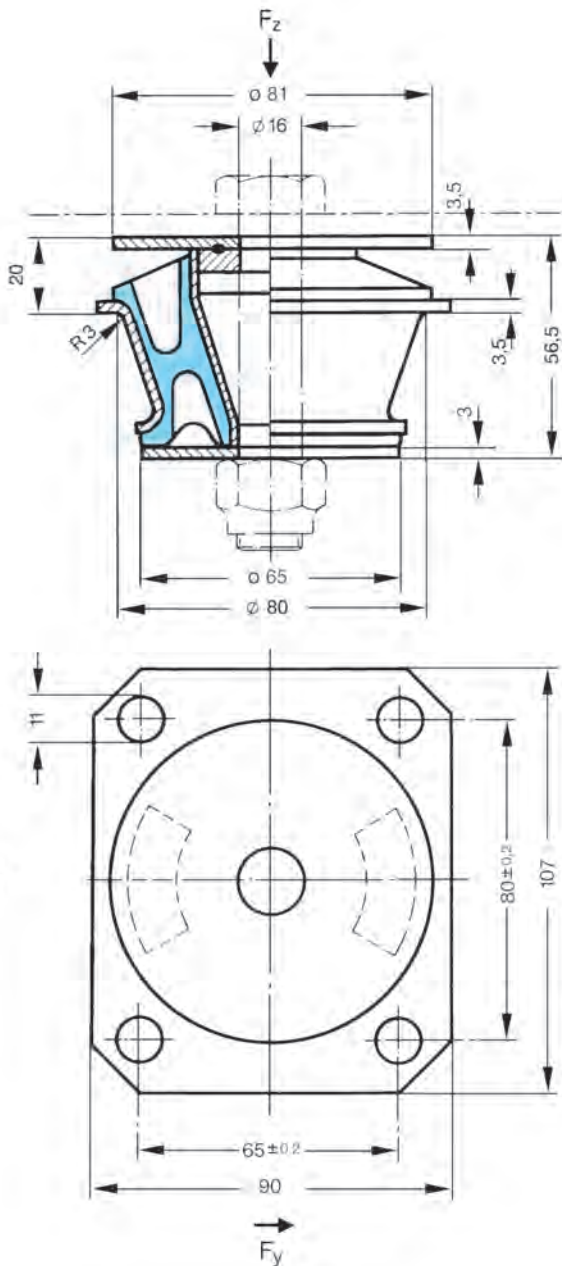

This item is listed in the catalogue and can be produced on request. Supply quantity on request.

Max. tension force of central threaded mount on inner section of cone
 $F_v = 50$ kN.

Supply Programme MEGI®-Cones

Megi cone
 Part No. 786 027 S5
 Versions:
 hard, medium, soft

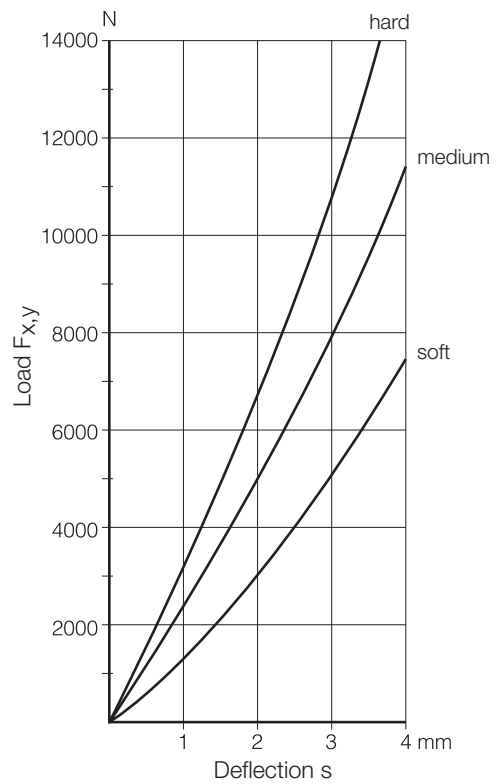
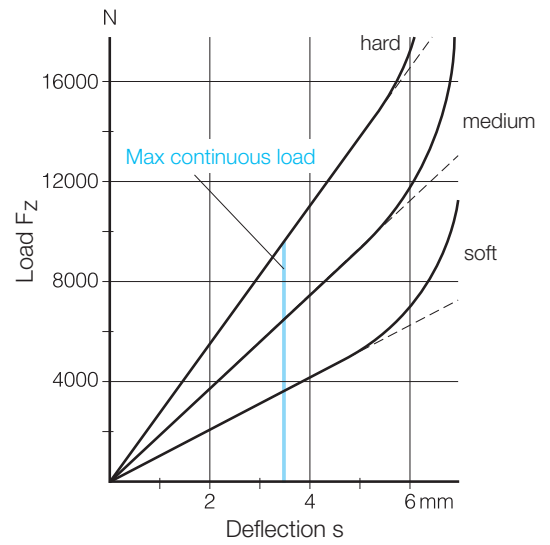
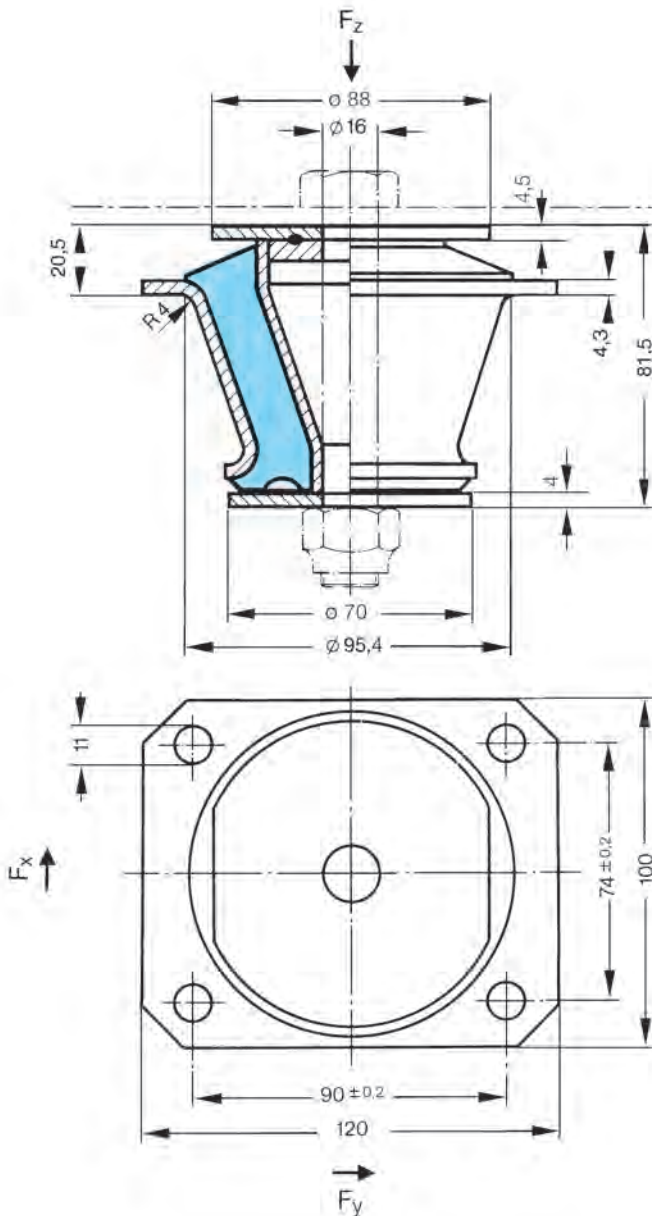

Stock item. Available only in packages of 4 each.

Max. tension force of central threaded mount on inner section of cone $F_V = 80$ kN.

Supply Programme MEGI®-Cones

Megi cone
 Part No. 786 030
 Versions:
 hard, medium, soft

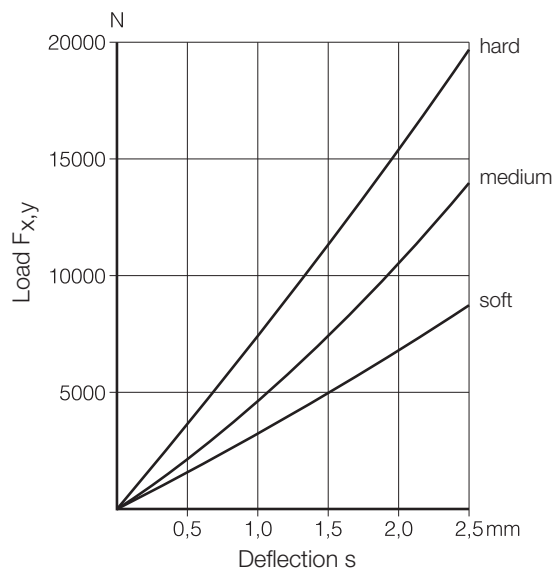
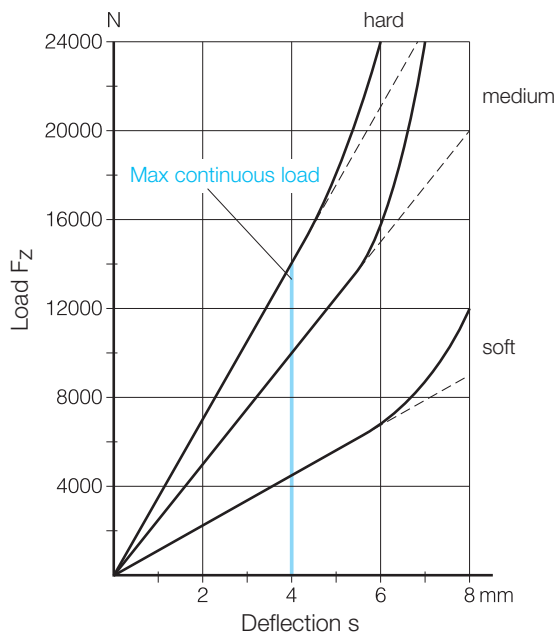
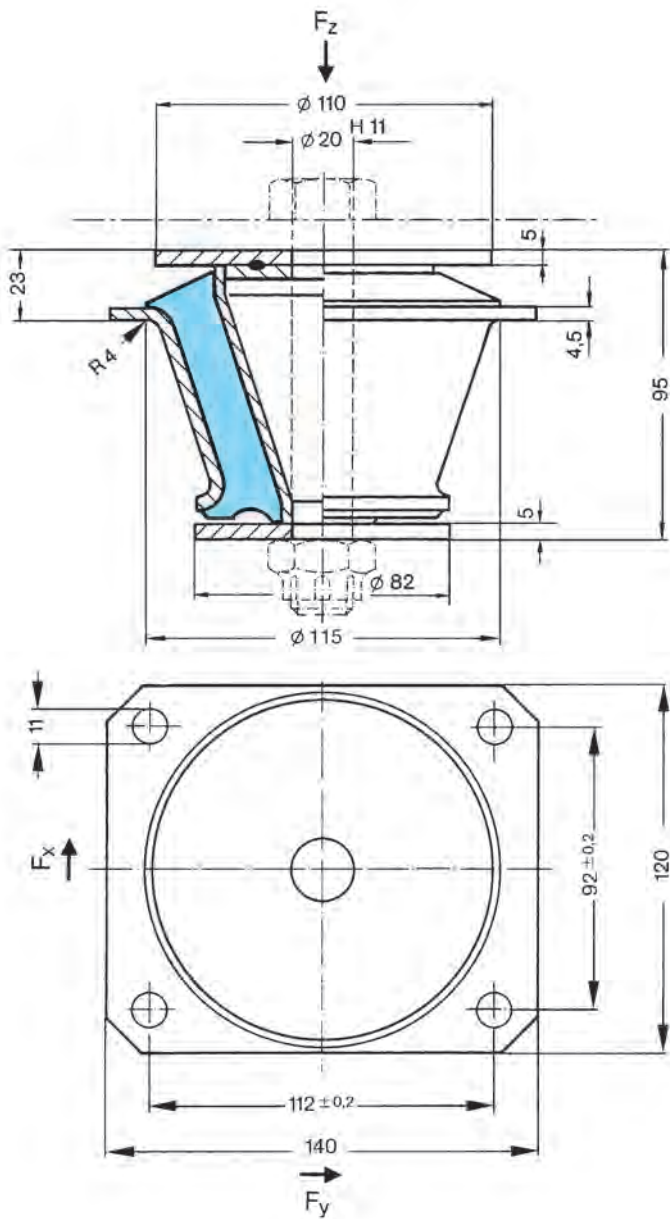

Stock item. Available only in packages of 4 each.

Max. tension force of central threaded mount on inner section of cone
 $F_v = 80$ kN.

MEGI® Bearings



Applications

Megi bearings are used in a wide variety of applications because they are available in several different types, e.g. pedestal bearings, flanged bearings, round or box-type bearings. Some of the bearings are supplied with recesses in the rubber cross-section in order to obtain different degrees of longitudinal and transverse rigidity. In addition, some bearings are fitted with a device preventing overloading or tear-off of the rubber metal bond, so that the possibility of damage from overloading is eliminated. Bearing 742 157 is produced using cast aluminium to reduce the weight.

Description

Megi bearings are simply and easy to install. The components, usually designed as pedestal bearings, are bolted directly to a frame or to the foundation. The slotted holes in the flange compensate for any deviations in the position of the drilled bolt holes.

Technical data

Megi bearings cover a load spectrum **up to 6 kN** depending on the bearing used and type of rubber. Further details are given in the tables.

Delivery

Depending on the item, the Megi buffers are available from stock in standard packages or as catalogue goods producible on short notice.



MEGI® = METALLGUMMI® (Rubber Metal)
Registered trademark.

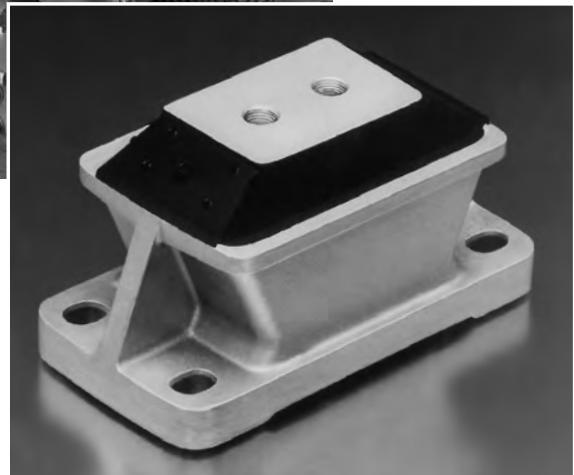

Supply Programme MEGI® Bearings

Megi bearing
Part No. 786 012

Versions:

hard, medium, soft

This bearing was developed for light loads. It is soft in the axial direction and has sufficient stiffness in the radial direction. The single-hole mount and the resulting installation possibilities make this bearing particularly suitable for sheet metal structures. These articles are zinc coated and Cr6-free passivated.

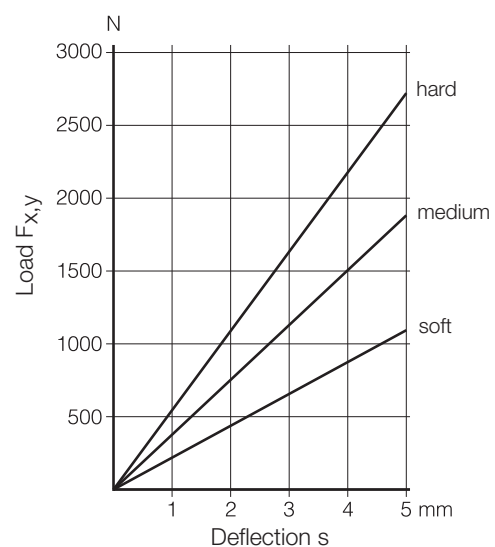
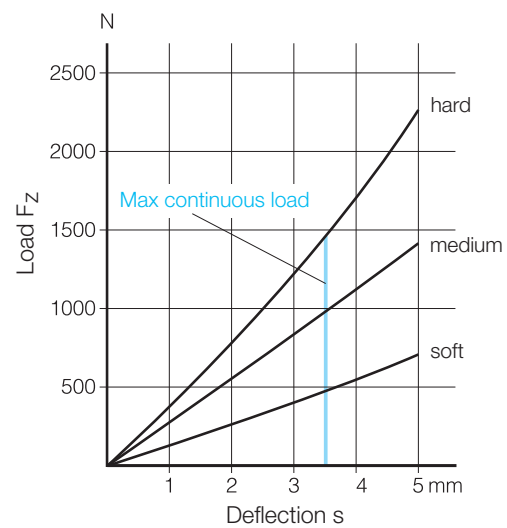
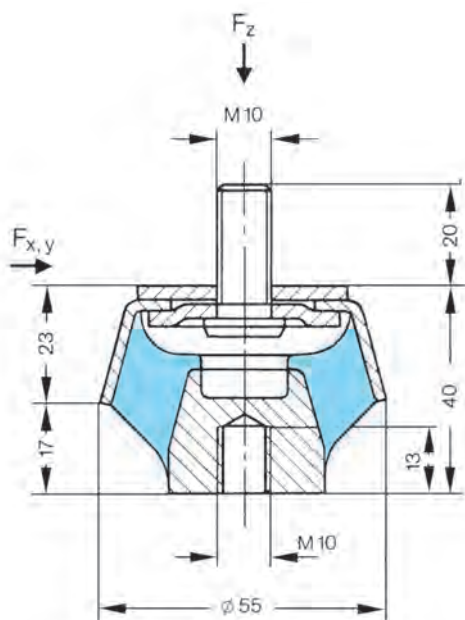

Stock item. Available only in packages of 12 each.

Supply Programme MEGI® Bearings

Megi bearing
Part No. 786 028

Versions:
hard, medium, soft

This rubber metal bearing can be used advantageously for flexible mounting of instruments, laboratory scales, etc. This bearing offers soft vertical suspension with sufficient rigidity in the horizontal direction.

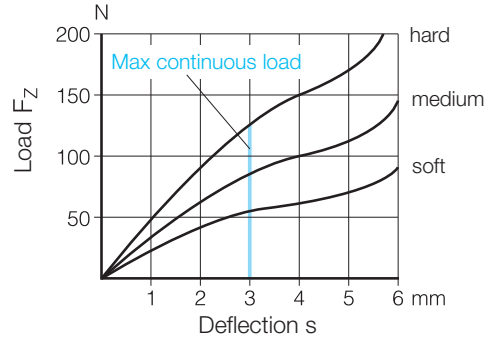
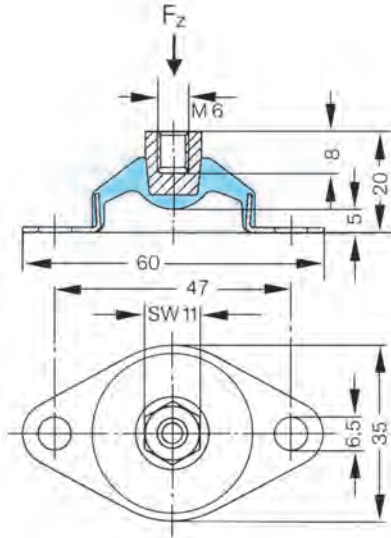

Megi bearing
Part No. 742 022

Versions:
hard, medium, soft

This rubber metal bearing is suitable for mounting equipment, fans, compressor units, etc. particularly in applications where soft vertical conversions combined with greater horizontal rigidity is required.

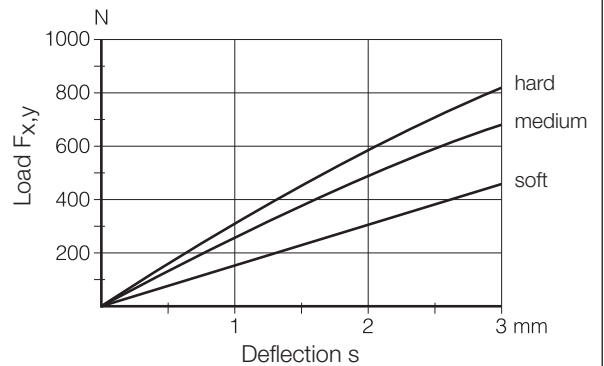
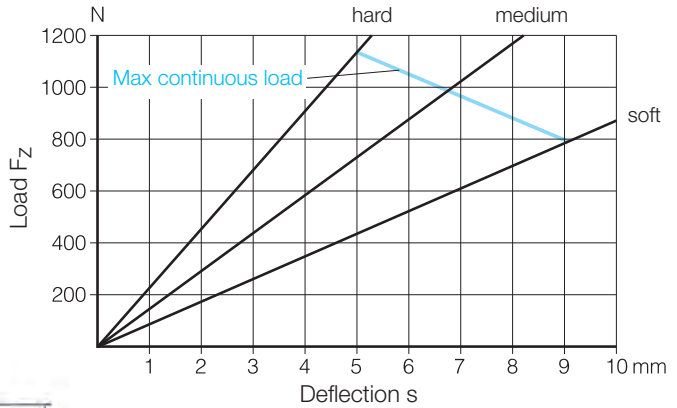
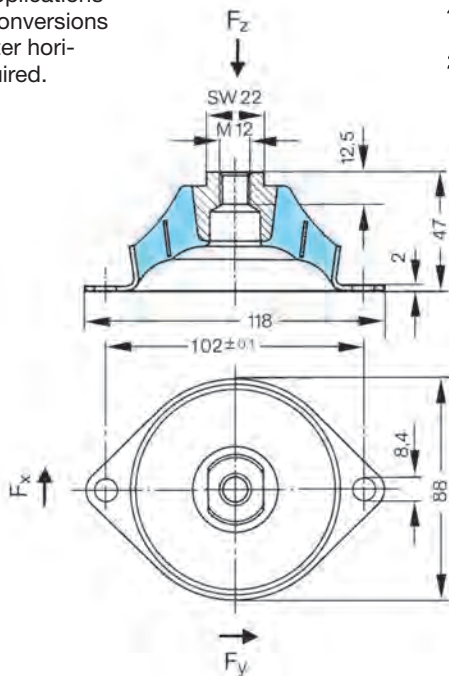

Stock item.

Available only in packages of 12 each.

All items not marked in blue are listed in the catalogue and can be produced on request. Supply quantities on request.

Supply Programme MEGI® Bearings

Megi bearing Part No. 742 034 S6

This round element is designed as a pedestal bearing and is suitable as a flexible mount for motors and stationary assemblies. The vertical deflection in the compression as well as tension direction is limited by the stop plates at the top and bottom making it impossible to overload this bearing.

Rated shore hardness (spring curve has priority):

- 40° Shore A
 - 50° Shore A
 - 60° Shore A
 - 70° Shore A
- Order No. 742 034 S6
- Order No. 742 034 S9

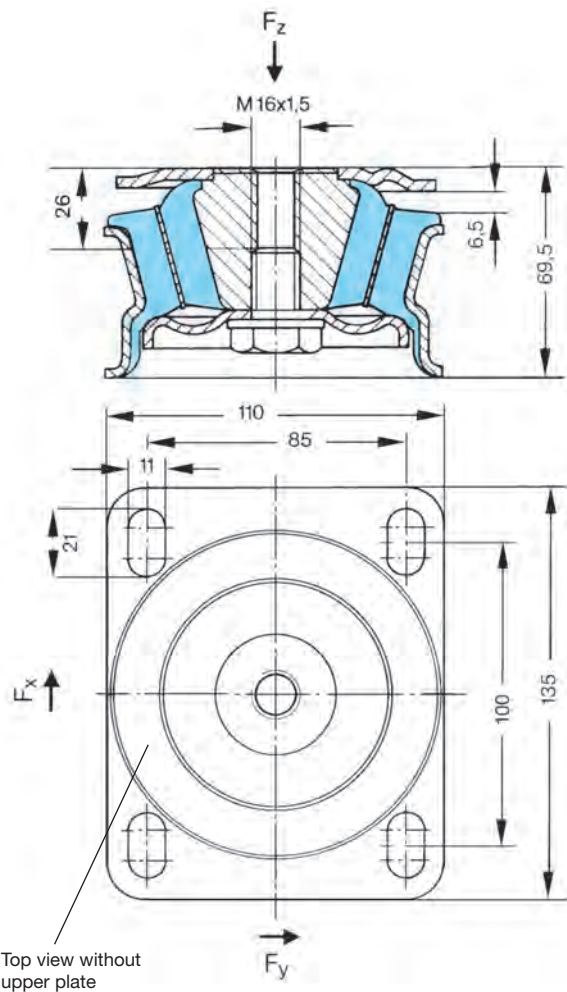

Top view without upper plate

| Spring rates in operating range in N/mm $\pm 20\%$ | | | | |
|--|-------------|-------------|-------------|-------------|
| Shore A | 40° ± 5 | 50° ± 5 | 60° ± 5 | 70° ± 5 |
| c_z | 325 | 430 | 610 | 785 |
| $c_{x,y}$ | 835 | 1325 | 1715 | 2160 |

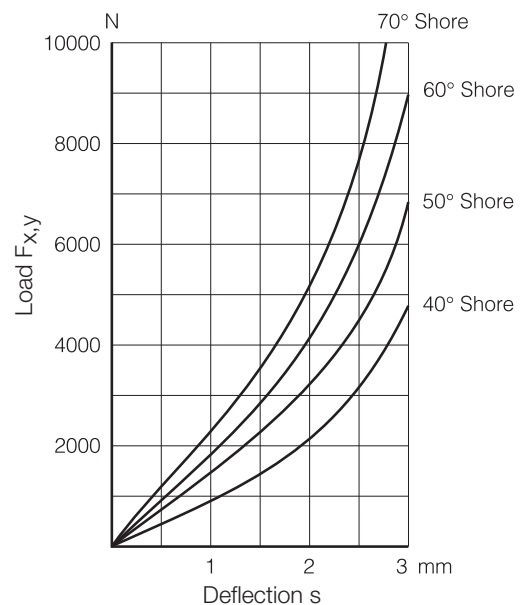
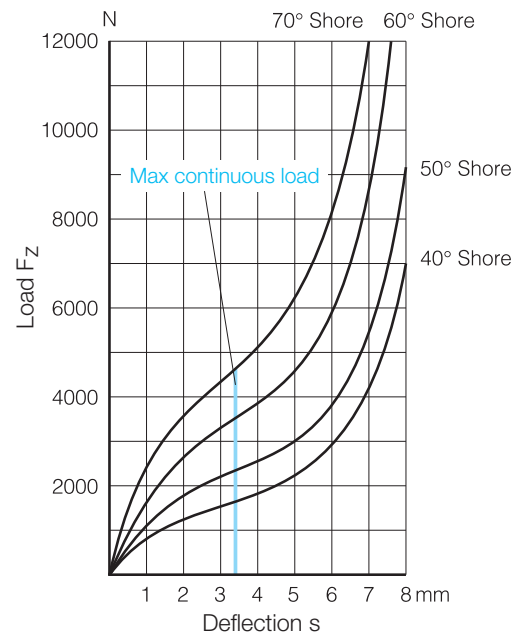

Stock item. Available only in packages of 4 each.

Supply Programme MEGI® Bearings

Megi bearing Part No. 742 034 S7

This round element is designed as a pedestal bearing and is suitable as a flexible mount for motors and stationary assemblies. The vertical deflection in the compression as well as tension direction is limited by the stop plates at the top and bottom making it impossible to overload this bearing.

Rated shore hardness (spring curve has priority):

- 40° Shore A
- 50° Shore A
- 60° Shore A
- 70° Shore A

Spring rates in operating range in N/mm ±20%

| Shore A | 40°±5 | 50°±5 | 60°±5 | 70°±5 |
|---------|-------|-------|-------|-------|
| c_z | 235 | 325 | 440 | 570 |
| c_x | 785 | 1130 | 1520 | 1960 |
| c_y | 345 | 540 | 740 | 980 |

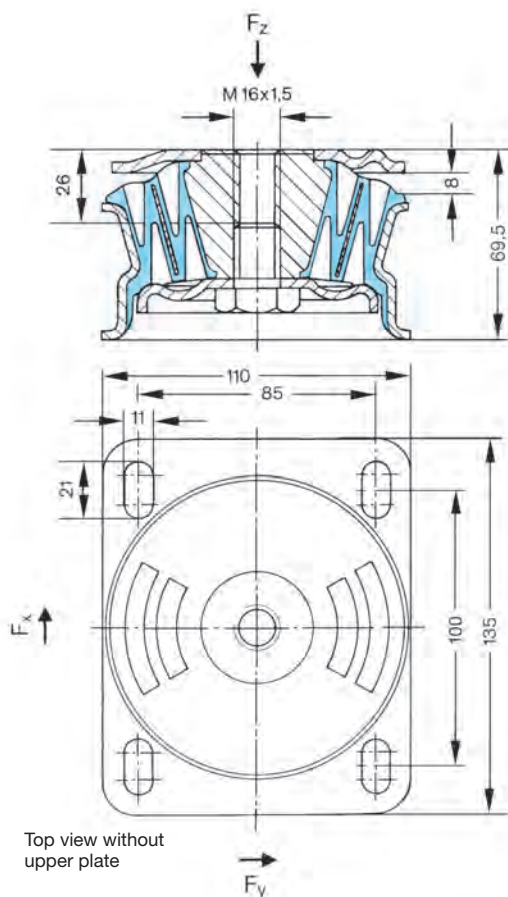

Top view without upper plate

Stock item. Available only in packages of 4 each.

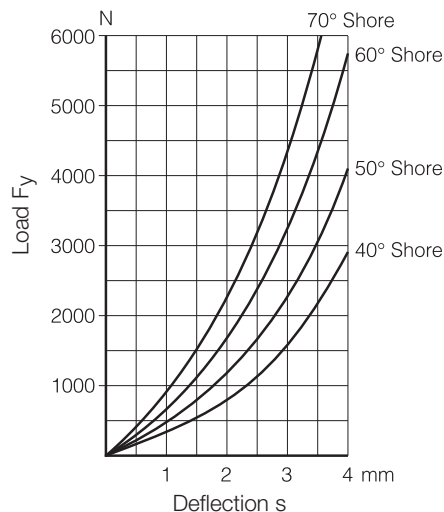
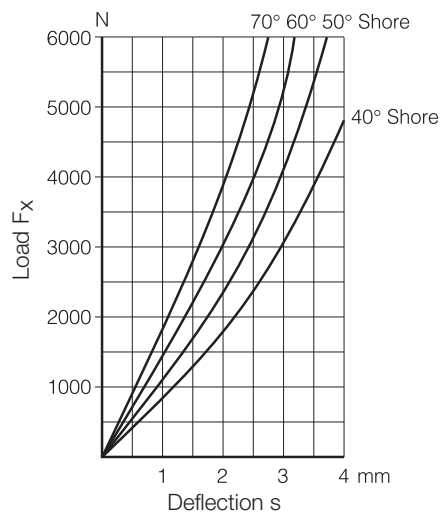
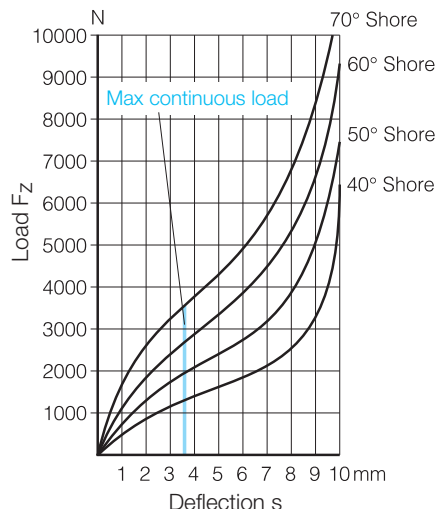

The recesses in the rubber provide different degree of longitudinal and transverse rigidity.

Supply Programme MEGI® Bearings

Megi bearing Part No. 742 157

This large Megi box-shaped bearing can be used as a flexible mount for extremely heavy engines in vehicles and stationary assemblies. Cast aluminium was used for the core and flange parts to reduce the weight.

Rated shore hardness (spring curve has priority):

40° Shore A

50° Shore A

60° Shore A

70° Shore A

Spring rates in operating range in N/mm $\pm 20\%$

| Shore A | 40° ± 5 | 50° ± 5 | 60° ± 5 | 70° ± 5 |
|---------|-------------|-------------|-------------|-------------|
| c_z | 450 | 680 | 1020 | 1570 |
| c_x | 1765 | 2450 | 3680 | 5690 |
| c_y | 170 | 235 | 345 | 590 |

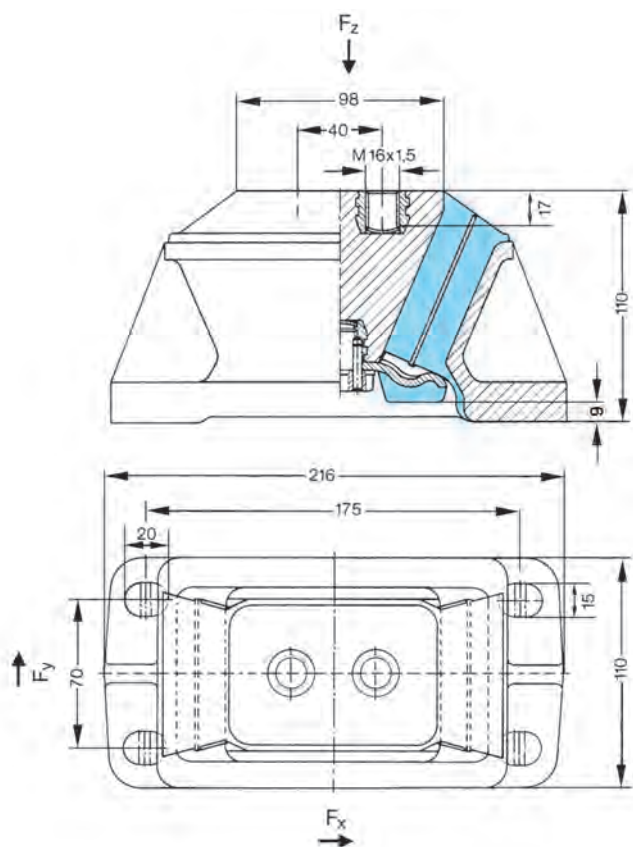

Stock item.

This item is listed in the catalogue and can be produced on request. Supply quantity on request.

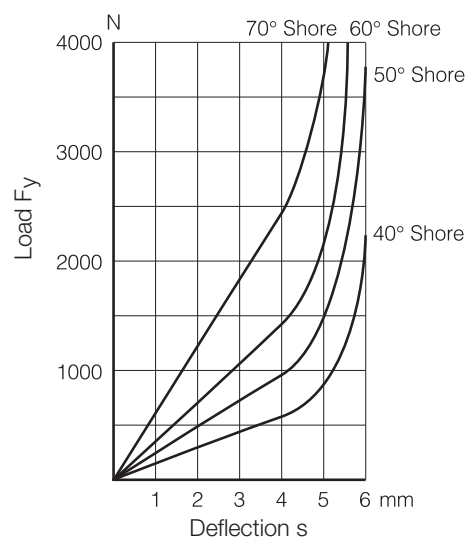
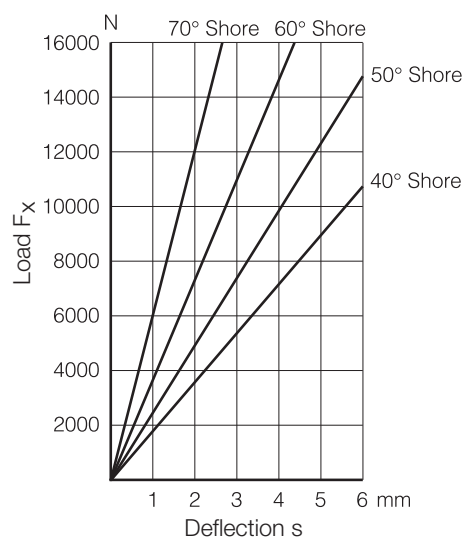
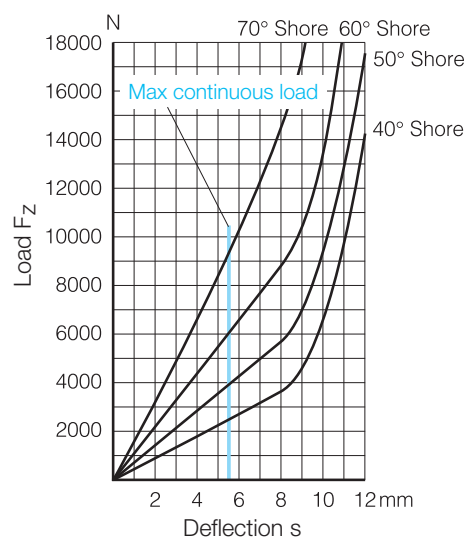

MEGI® Ring Elements



Applications

Megiflex-disk and Megi annular buffers are simple standard elements in terms of the part geometry which are used as flexible mounts in light and heavy machine construction as well as automotive applications.

Megiflex-disk, which can be combined to form spring assemblies, are frequently used as buffer elements on rail vehicles. They can also be assembled to form tension/thrust elements. Various spring constants and therefore deflection values can be achieved by assembling a number of these disks in series.

Megi annular buffers are spring elements which are usually used as pairs at each bearing points. They are particularly effective when used as auxiliary mounts to interrupt structure-borne sound vibrations.

Annular buffers with tear-off protection can be used for many applications from resiliently suspended driver's seat to flexibly mounted truck cabs, from pipe mounts to control cabinets; minor transfer forces are absorbed.

Description

Megiflex-disk are prestressed when fitted and absorb both tensile and compressive forces. In spring assemblies made up of a large number of individual elements, it is necessary to insert supports to prevent buckling and a guide is required for the entire spring column. The number of spring elements assembled in series must be calculated to ensure that the load does not exceed the initial tension range. Transfer forces cannot be absorbed, or only to a small extent. Mounting plates must be provided by the customer.

Megi annular buffers are installed in pairs and decompressed. They provide a relatively hard flexible mount for tension and compression. The primary function of the element is to interrupt transmission of structure-borne noise.

Technical Data

Megiflex-disk absorb impact loads **up to approx. 500 kN** depending on the application and type of rubber used. Megi annular buffers cover a load range up to approx. 3750 N.

Delivery

Depending on the item, the Megi buffers are available from stock in standard packages or as catalogue goods producible on short notice.





MEGI® = METALLGUMMI® (Rubber Metal)
Registered trademark.

Assembly

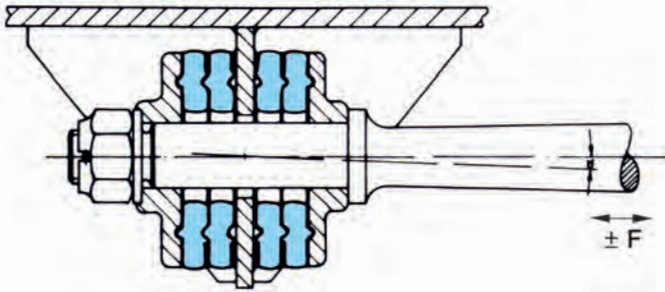

Supply Programme MEGI® Ring Elements

Megiflex disks

Version:

medium

Megiflex disks are prestressed when fitted and absorb both tensile and compressive forces. In spring assemblies made up of a large number of individual elements, it is necessary to insert supports to prevent buckling and a guide is required for the entire spring column.

The number of spring elements assembled in series must be calculated to ensure that the load does not exceed the initial tension range. Transfer forces cannot be absorbed, or only to a small extent. Mounting plates must be provided by the customer.

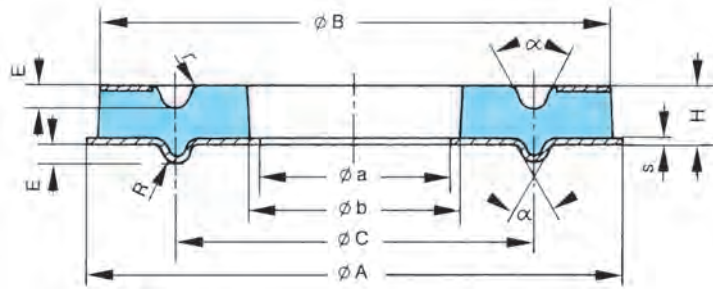

| Dimensions | | | | | | | | | | | Technical data medium | | | Number in package Part No. package | |
|------------|-----|-----|-----|-----|------|------|-----|----|-----|-----|-----------------------------|--------|-----------------------|---------------------------------------|----|
| A Ø | a Ø | B Ø | b Ø | C Ø | H | s | E | α° | R | r | Max. continuous static load | | infrequent peak load* | | |
| | | | | | | | | | | N | | s (mm) | N | | |
| 65 | 26 | 62 | 30 | 46 | 11 | 1 | 2,5 | 60 | 2 | 0,5 | 6850 | 1,8 | 17650 | 741 473 | 20 |
| 95 | 45 | 90 | 50 | 70 | 10,5 | 1,5 | 2,5 | 60 | 2,5 | 1 | 7850 | 1,4 | 20600 | 741 481 | 10 |
| 100 | 35 | 90 | 40 | 64 | 27,5 | 1,5 | 3,5 | 60 | 3 | 1 | 9800 | 6,4 | 58850 | 741 444 | 10 |
| 110 | 30 | 102 | 38 | 76 | 20,8 | 1,75 | 3,5 | 60 | 3 | 1 | 13750 | 3,7 | 62800 | 741 401 | 6 |
| 110 | 30 | 102 | 38 | 76 | 25,8 | 1,75 | 3,5 | 60 | 3 | 1 | 12750 | 5,1 | 73600 | 741 409 | - |
| 110 | 40 | 102 | 44 | 76 | 15,8 | 1,75 | 3,5 | 60 | 3 | 1 | 14200 | 2,4 | 49050 | 741 493 | 6 |
| 130 | 55 | 123 | 60 | 90 | 16 | 2 | 5 | 60 | 4 | 2 | 17150 | 2,1 | 57900 | 741 488 | 6 |
| 153 | 55 | 145 | 60 | 102 | 30 | 2 | 5 | 60 | 4 | 2 | 29450 | 6,2 | 107900 | 741 472 | 4 |
| 155 | 75 | 150 | 80 | 115 | 12 | 2 | 5 | 60 | 4 | 2 | 23550 | 1,2 | 73600 | 741 485 | - |
| 160 | 90 | 155 | 95 | 125 | 12 | 2 | 5 | 60 | 4 | 2 | 22550 | 1,3 | 66700 | 741 486 | - |
| 164 | 60 | 156 | 64 | 110 | 16 | 2 | 4 | 60 | 4 | 2 | 30400 | 1,8 | 88300 | 741 424 | - |
| 164 | 60 | 156 | 64 | 110 | 23 | 2 | 4 | 60 | 4 | 2 | 33350 | 3,6 | 122650 | 741 432 | 4 |
| 210 | 55 | 200 | 60 | 154 | 20 | 2 | 6 | 60 | 6 | 1,2 | 45150 | 2 | 153050 | 741 482 | - |
| 210 | 95 | 200 | 100 | 154 | 20 | 2 | 6 | 60 | 6 | 1,2 | 45150 | 2,6 | 173650 | 741 436 | 4 |
| 220 | 66 | 200 | 100 | 154 | 62 | 2 | 6 | 60 | 6 | 1,2 | 32400 | 13 | 103000 | 741 407 | - |
| 240 | 70 | 230 | 76 | 154 | 25 | 2 | 6 | 60 | 5 | 2 | 60800 | 2,9 | 217800 | 741 434 | 4 |
| 265 | 78 | 250 | 90 | 166 | 27,8 | 2,75 | 7 | 60 | 6 | 2 | 82400 | 3,2 | 276650 | 741 427 | - |

* F_{zul} is the **permissible continuous static load** upon which a fluctuating dynamic load can be superimposed. The permissible loadings given represent only approximate maximum values of static loading for guidance.

Stock item. Available only in standard packages.

All items not marked in blue are listed in the catalogue and can be produced on request. Supply quantities on request.

Supply Programme MEGI® Ring Elements

Megi Annular Buffers

Megi annular buffers are ring-shaped rubber metal parts with a collar on one of the two metal plates for centring. Megi annular buffers can be subjected to compression and shearing stress.

Megi annular buffers are used as flexible mounts where tensile forces are expected. They are used in pairs decompressed against one another.

Rubber hardnesses:

- hard approx. 70 Shore A
- medium approx. 60 Shore A
- soft approx. 45 Shore A

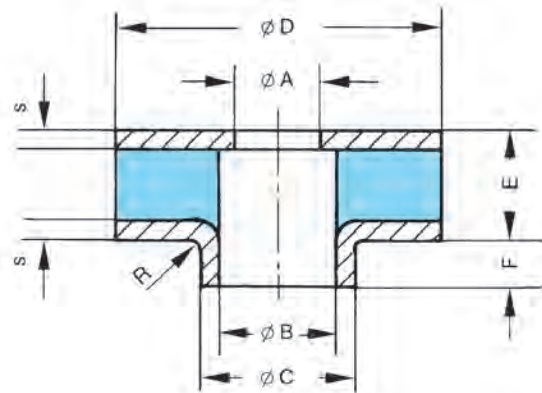

| Dimensions in mm | | | | | | | | | | Technical data | | | | | | | | | Number in package Part No. | | | |
|------------------|------|------|----|----|------|---|-----|-----|---------------------------|-------------------------------|-------------------------------|-------------------------------|--------------|---------|-----|-----|-----|------|-------------------------------|-----|---------|----|
| | | | | | | | | | | Compression stress | | | Shear stress | | | | | | | | | |
| D | A | B** | C | E | F | G | s | R | Spring rate c_z in N/mm | Perm. load $F_{Perm.}$ * in N | Spring rate $c_{x,y}$ in N/mm | Perm. load $F_{Perm.}$ * in N | Part No. | package | | | | | | | | |
| | | | | | | | | | hard | medium | soft | hard | medium | soft | | | | | | | | |
| 36 | 6,2 | 6,2 | 15 | 10 | 6 | - | 1 | 1 | 2000 | 1350 | 800 | 2600 | 1600 | 950 | 170 | 110 | 65 | 500 | 300 | 180 | 741 029 | - |
| 36 | 8,5 | 12 | 18 | 10 | 4 | - | 1 | 1 | 1550 | 1000 | 620 | 1900 | 1200 | 700 | 150 | 100 | 60 | 400 | 250 | 150 | 741 027 | 50 |
| 36 | 16,6 | 16,6 | 20 | 8 | 3 | - | 1 | 1 | 1900 | 1250 | 770 | 1800 | 1100 | 650 | 175 | 115 | 70 | 300 | 200 | 120 | 741 092 | 50 |
| 50 | 16,5 | 20 | 23 | 13 | 9,5 | - | 1,5 | 2,5 | 2200 | 1500 | 900 | 3700 | 2300 | 1350 | 225 | 150 | 90 | 800 | 500 | 300 | 741 020 | 50 |
| 60 | 20,5 | 24 | 27 | 13 | 10,5 | - | 1,5 | 2,5 | 3000 | 2000 | 1050 | 6100 | 3800 | 2200 | 325 | 220 | 130 | 1100 | 700 | 410 | 741 026 | 25 |

* $F_{Perm.}$ is the **permissible continuous static load** upon which a fluctuating dynamic load can be superimposed. The permissible loads given represent only approximate guide values for the static load.

** Inner diameter (dimension B) on Part 741 027/-029/-92 is rubber-coated

Assembly

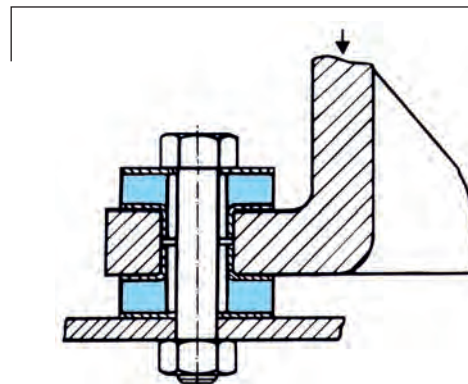

Stock items: Available only in standard packages.
All items not marked in blue are listed in the catalogue and can be produced on request. Supply quantities on request.

MEGI® U-V-W-Shaped Elements · MEGI® Ceiling Elements



Applications

Megi-U bearings are suitable for reducing shock or isolation vibration in apparatus and equipment. The impact and excitation forces must remain small and the permissible maximum static load should be exceeded only slightly.

Megi-V-W parts have a variety of uses in mounting sensitive instruments, meters and indicating devices requiring protection against shock.

The Megi ceiling element is used purely for suspension purposes and is especially suitable for flexible suspension of light fittings, apparatus and pipe work from ceilings. A tear-off protection feature is built in.

Description

U-V-W elements should be installed in such a manner that the load is either at right angles or parallel to the metal plates. These elements should never be subjected to tensile

stress. The design of the **Megi ceiling element** enables it to absorb flexibly even impact or acceleration forces acting on the suspended parts. The cross-ties, which is vulcanised in, holds the suspended parts securely, even when they are subjected to extremely heavy shocks.

Technical Data

The following maximum loads can be supported by the previously described U-V-W elements and ceiling element:
Shore hardness: hard, medium, soft

Delivery

Available as stock item in standard packages

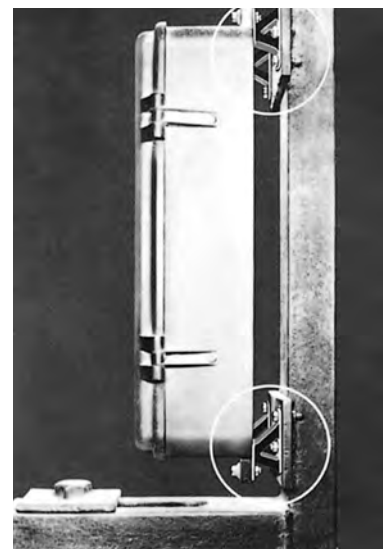

| Part | Compression | Shear | Tension |
|-----------------------|-------------|--------------|-------------|
| Megi-U element up to | | 350-1400 [N] | |
| Megi-V element up to | 100-300 [N] | 40-150 [N] | |
| Megi-W element up to | 200-600 [N] | 70-240 [N] | |
| Ceiling element up to | | | 300-750 [N] |

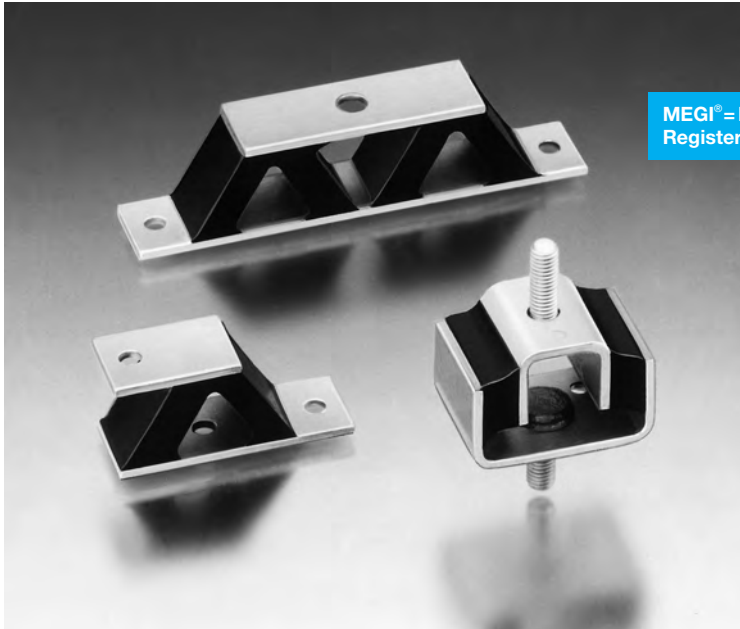

MEGI® = METALLGUMMI® (Rubber Metal)
Registered trademark.



Supply Programme MEGI® U-V-W-Shaped Elements

Megi-U bearing
Part No. 782 000

Versions:

hard, **medium**, soft

The Megi-U bearing is suitable as a mount for reducing shock or isolating vibration in apparatus and equipment. The impact and excitation forces must remain low.

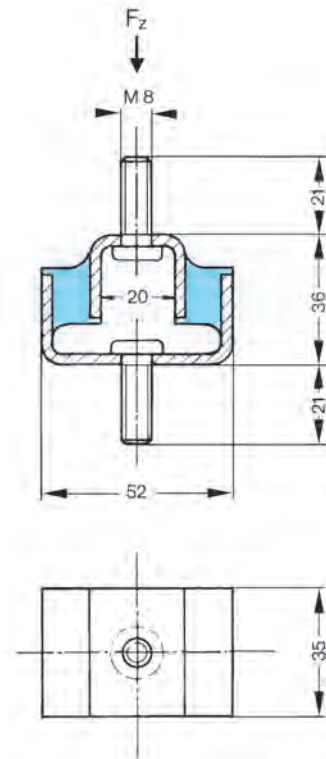
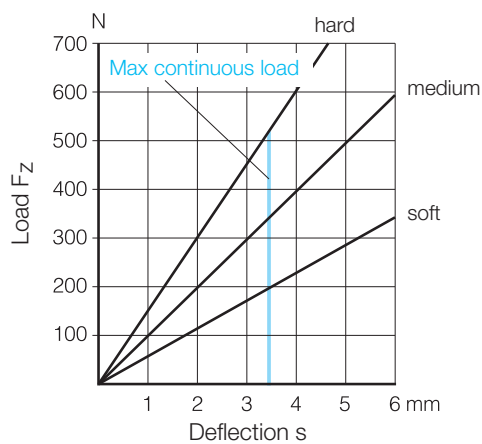

Megi-U bearing
Part No. 782 001

Versions:

hard, **medium**, soft

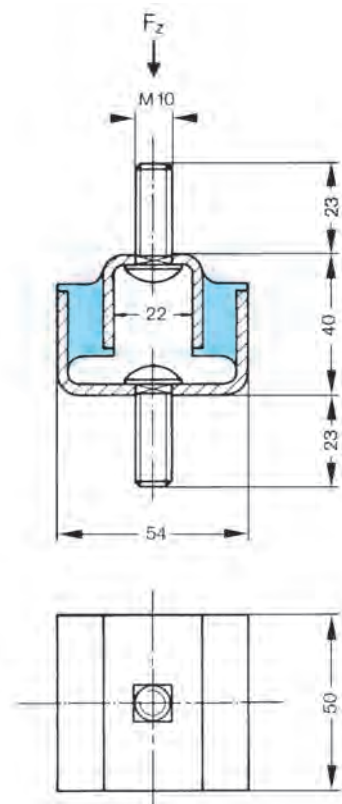
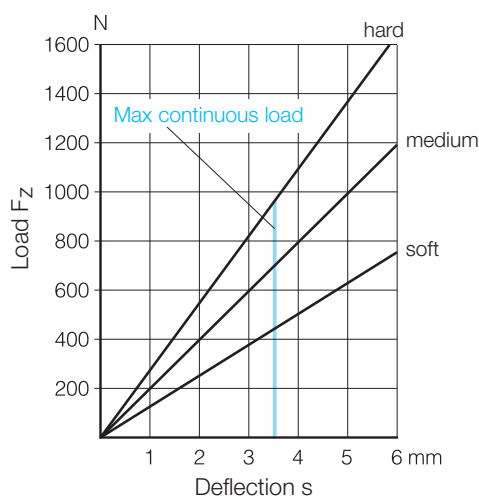

Stock items: Available only in standard packages.
782 000 = 12 parts. 782 001 = 8 parts

All items not marked in blue are listed in the catalogue and can be produced on request. Supply quantities on request.

Supply Programme MEGI® U-V-W-Shaped Elements

Megi-V bearing
Part No. 786 002
Versions:

hard, medium, soft

Megi-V bearings have a variety of applications as mounts for sensitive instruments, etc., which require protection against shock. They can be loaded in the compression direction (at right angles to the metal plate) as well as in the shear direction (parallel to metal plates).

Maximum permissible loads:
 Under continuous static load, the spring deflection should generally not be greater than 3.5 mm in the compression direction and not more than 5 mm in the shearing direction. The loads corresponding to these deflections are given in the spring curves.

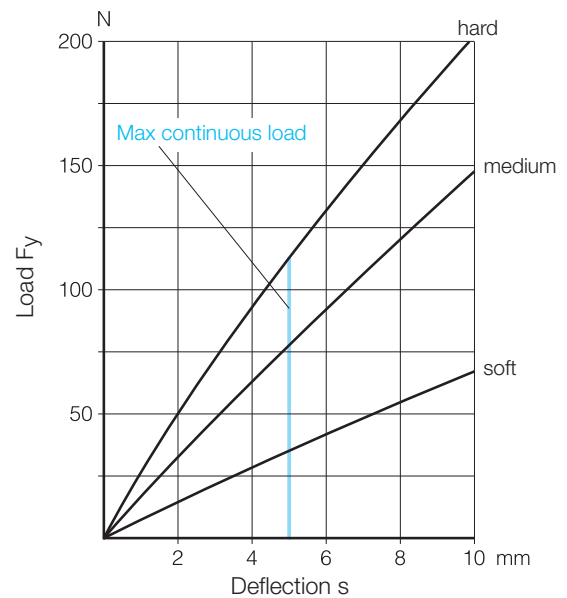
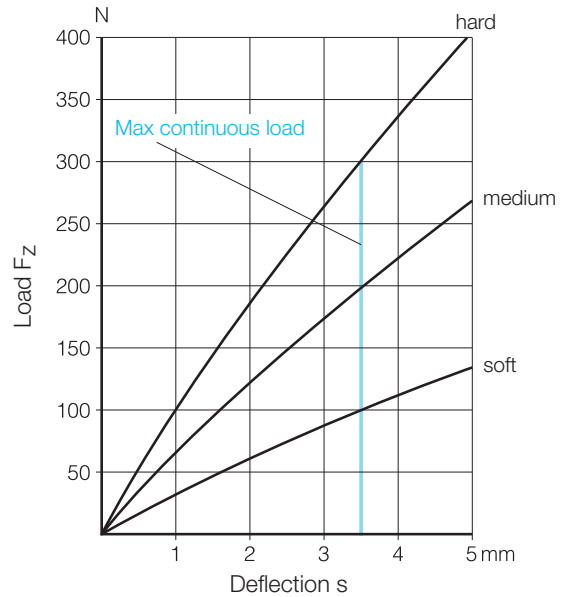
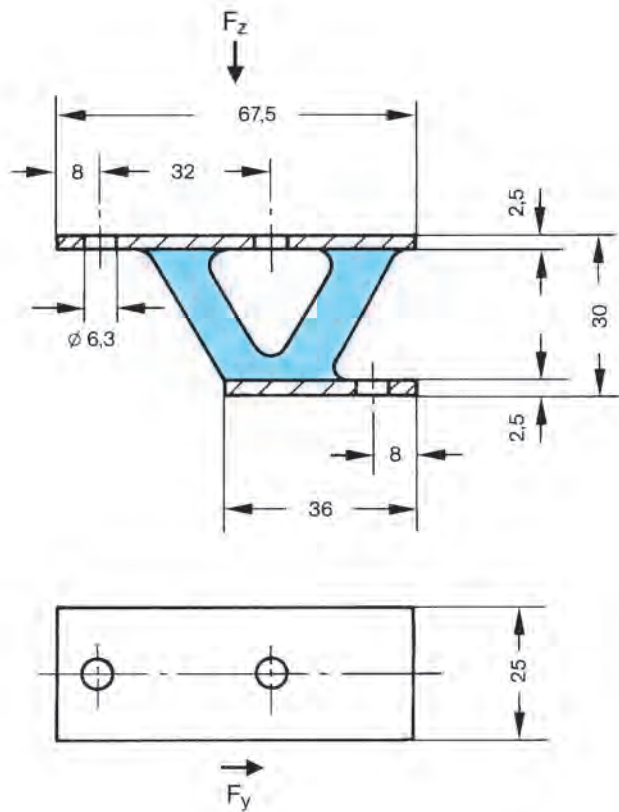

Stock items: Available only in packages of 20 each.

Supply Programme MEGI® U-V-W-Shaped Elements

Megi-W bearing

Part No. 786 001

Versions:

hard, medium, soft

Megi-W bearings have a variety of applications as mounts for sensitive instruments, etc., which require protection against shock. They can be loaded in the compression direction (at right angles to the metal plate) as well as in the shear direction (parallel to metal plates).

Maximum permissible loads:

Under continuous static load, the spring deflection should generally not be greater than 3.5 mm in the compression direction and not more than 5 mm in the shearing direction. The loads corresponding to these deflections are given in the spring curves.

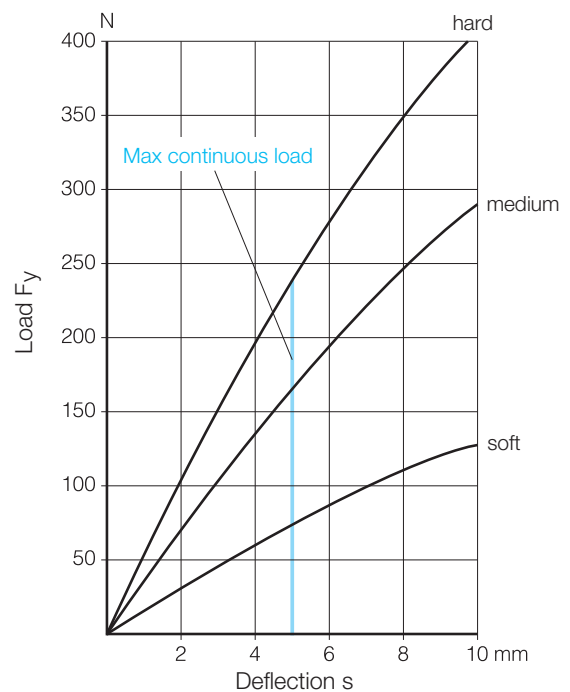
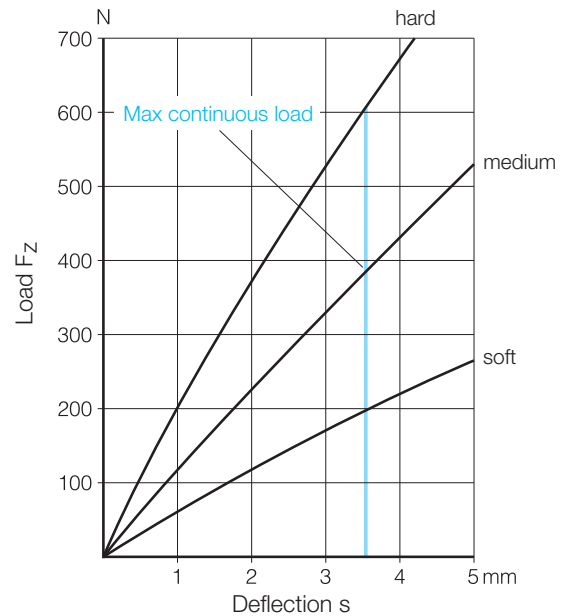
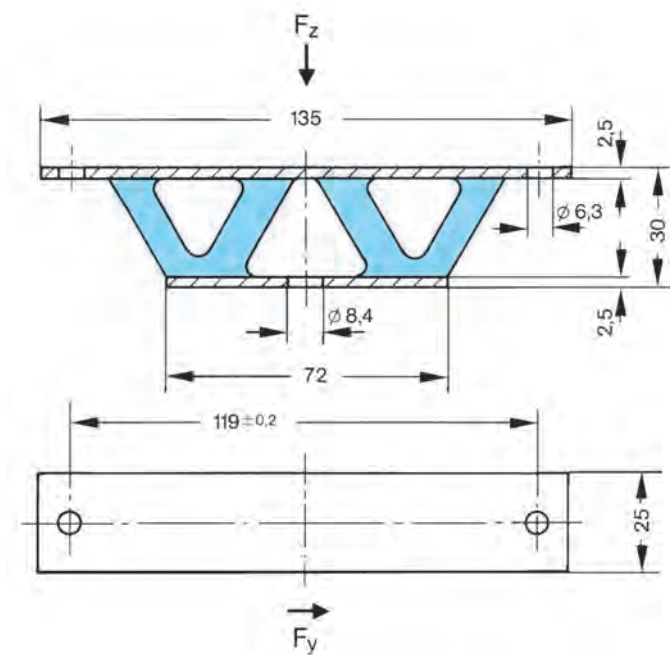

Stock items: Available only in packages of 12 each.

All items not marked in blue are listed in the catalogue and can be produced on request. Supply quantities on request.

Supply Programme MEGI® Ceiling Element

Megi ceiling element

Part No. 782 002

Versions:

hard, medium, soft

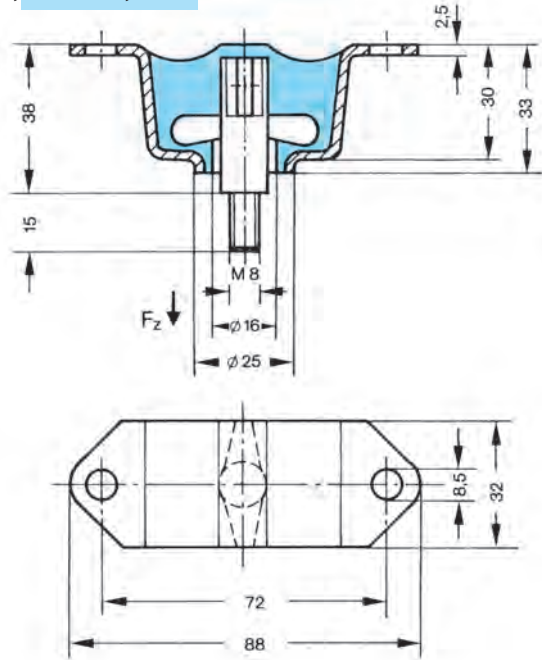

Megi ceiling element

Part No. 782 002 S1

Versions:

hard, medium, soft

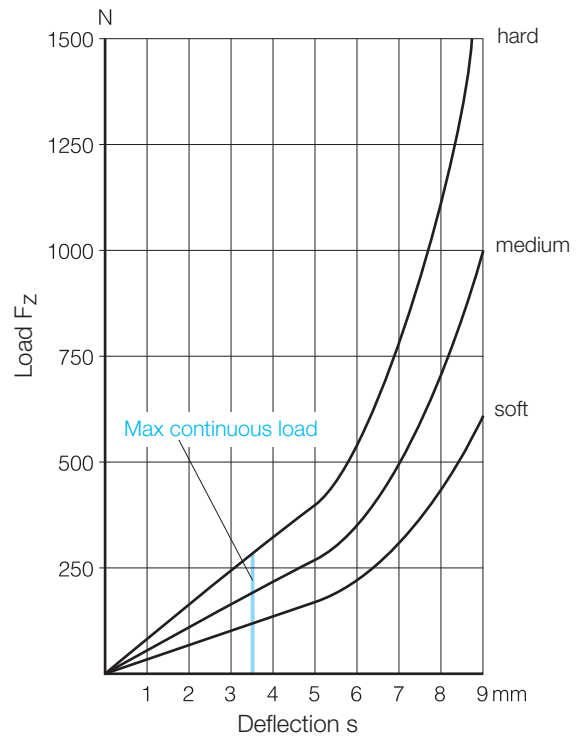
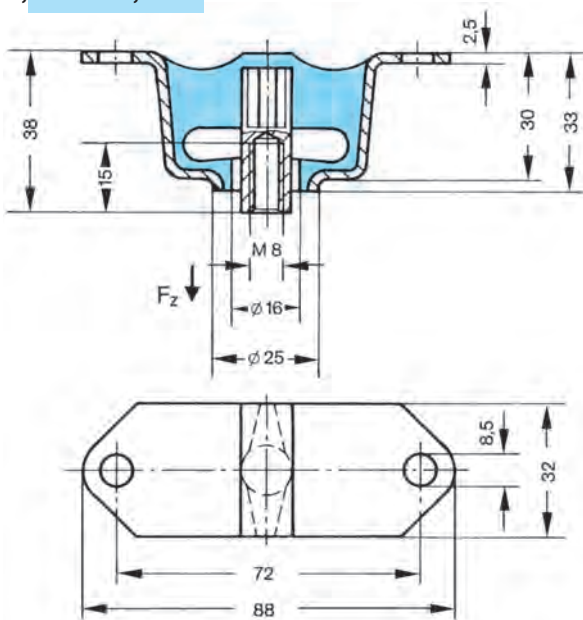

Stock items: Available only in packages of 10 each.

All items not marked in blue are listed in the catalogue and can be produced on request. Supply quantities on request.

MEGI® Bushes · MEGI® Rings



Applications

Megi bushes are used as flexible joints in motor vehicles and all branches of mechanical engineering. Megi bushes can withstand high radial stress because they are pre-stressed using a special process. The axially stiff AS bushes are excellent for use with high thrust loads. Megi bushes can be subjected in continuous operation to angular distortion of $+15^\circ$ whereby a return moment proportional to the angle of twist is developed. As flexible joints, Megi bushes are completely maintenance-free. They operate noiselessly, are sound insulating and have a long service life.

Description

Generally, the outer tube of Megi bushes is held in place by a pressed fit or by the use of clamp bearings. The inner tube can be held, for example, by pressure against the end phase. In this case, the bolt passing through the H9 hole in the bush pressed the checked collar (e.g. plates) against the end phase of the inner tube.

Technical Data

Megi bushes cover a range of radial loads up to 15 kN depending on the bush used: Further details are given in the tables.

Delivery

Depending on the item, the Megi buffers are available from stock in standard packages or as catalogue goods producible on short notice.

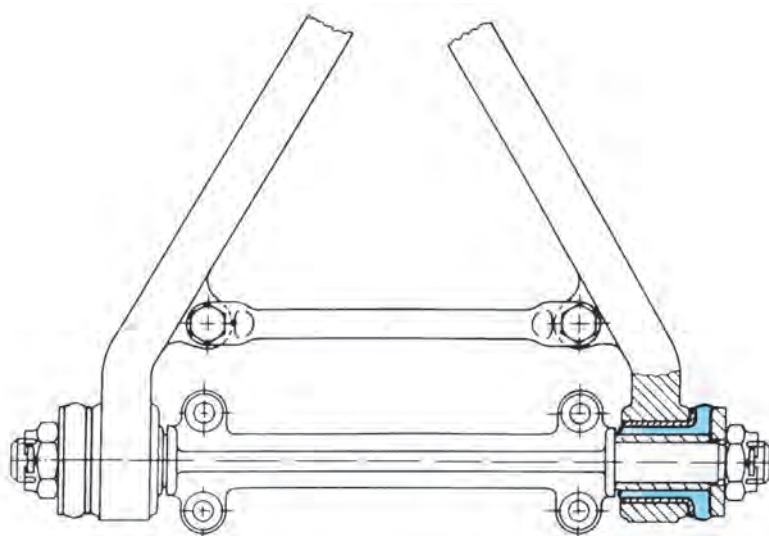



MEGI® = METALLGUMMI® (Rubber Metal)
Registered trademark.

Supply Programme MEGI® Bushes

Megi HL bushes

Megi HL bushes can be subjected to radial, axial and torsional loads without the rubber being displaced in relation to the metal parts. A small cardanic angular displacement of the axis of the inner tube in relation to that of the outer tube or vice versa, is possible. The bearings are, however, relatively resistant to such angular displacement, whereby the resistance depends on the thickness, hardness and length of the rubber section.

The maximum continuous and peak radial, thrust and torsional loads are given in the table. They apply for highly resilient, particularly durable types of rubbers with a Shore A hardness of approx. 50°.

Types of deformation of Megi HL bushes:

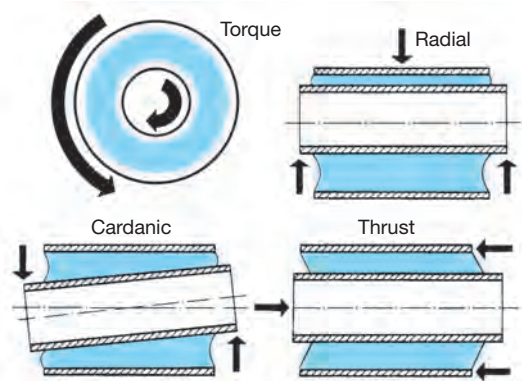

| Dimensions | | | | Technical data | | | | | | | | | | Number in package Part No. package | |
|---------------------|---------------------|----------------------|----------------------|------------------------|------------------------|-----------------------|-----------------------|----------------------------|-------------------|---------------------------|---------------------------|-----------------------|------------|---------------------------------------|--|
| Outer diameter | Inner diameter | Length of inner tube | Length of outer tube | Radial load | | Axial load | | Torsion | | | | | | | |
| | | | | Max. stat. radial load | Radial spring constant | Max. stat. axial load | axial spring constant | Max. stat. torsional angle | Max. stat. torque | Torsional spring constant | Max. peak torsional angle | Max. peak torque | | | |
| D mm | d mm | l mm | L mm | F _r N | C _r N/mm | F _a N | C _a N/mm | φ degree | M _d Nm | C _φ Nm/degree | φ max degree | M _{d,max} Nm | | | |
| 24 ^{+0,08} | 10 ^{H9} | 17 ^{±0,1} | 14 ^{+0,5} | 200 | 491 | 160 | 103 | 15 | 1,3 | 0,09 | 30 | 2,6 | 735 009 S2 | 20 | |
| 26 ^{+0,08} | 12 ^{H9} | 24 ^{±0,2} | 17,5 ^{+0,2} | 690 | 1962 | 680 | 226 | 13 | 4,4 | 0,338 | 26 | 9,0 | 735 035 | 30 | |
| 26 ^{+0,08} | 12 ^{H9} | 36 ^{±0,2} | 32 ^{+0,2} | 1370 | 3924 | 840 | 422 | 13 | 8,0 | 0,61 | 26 | 15,0 | 735 091 | 50 | |
| 30 ^{±0,08} | 13 ^{H9} | 40 ^{-0,4} | 40 ^{-0,4} | 1670 | 3335 | - | 392 | 15 | 9,0 | 0,6 | 30 | 18,0 | 735 059 | - | |
| 30 ^{±0,08} | 14 ^{±0,15} | 76 ^{±0,1} | 67 ^{±0,1} | 3920 | 8829 | 2310 | 765 | 15 | 19,0 | 1,24 | 30 | 37,0 | 735 067 | - | |
| 34 ^{±0,15} | 18 ^{H11} | 36 ^{±0,2} | 32 ^{±0,5} | 1570 | 3237 | 830 | 417 | 14 | 12,0 | 0,9 | 28 | 25,0 | 735 043 | 20 | |
| 40 ^{±0,2} | 26 ^{±0,2} | 45 ^{±0,2} | 40 ^{-0,2} | 4910 | 14715 | 2550 | 1020 | 7 | 28,0 | 3,9 | 14 | 55,0 | 735 081 | 20 | |
| 45 ^{+0,08} | 20 ^{H9} | 62,5 ^{±0,2} | 55 ^{-0,2} | 3430 | 3924 | 1860 | 540 | 15 | 22,0 | 1,5 | 30 | 44,0 | 735 022 S1 | 20 | |
| 45 ^{+0,08} | 20 ^{H9} | 62,5 ^{±0,2} | 59,5 ^{-0,2} | 3920 | 4905 | 1910 | 608 | 15 | 30,0 | 2,0 | 30 | 60,0 | 735 022 | 20 | |
| 48 ^{-0,1} | 27,8 ^{H9} | 67 ^{±0,2} | 60 ^{±0,2} | 8830 | 14715 | 3340 | 961 | 11 | 60,0 | 5,3 | 22 | 120,0 | 735 074 | - | |
| 48 ^{-0,1} | 27,8 ^{H9} | 73 ^{±0,2} | 60 ^{±0,2} | 8830 | 14715 | 6300 | 961 | 11 | 60,0 | 5,3 | 22 | 120,0 | 735 075 | - | |
| 50 ^{±0,2} | 25 ^{H9} | 67,5 ^{±0,2} | 65,5 ^{-0,2} | 6380 | 6082 | 760 | 755 | 15 | 60,0 | 3,9 | 30 | 120,0 | 735 040 | 20 | |
| 55 ^{+0,08} | 25 ^{H9} | 93,5 ^{±0,2} | 89,5 ^{-0,2} | 9810 | 8829 | 1650 | 824 | 15 | 70,0 | 4,6 | 30 | 140,0 | 735 023 | 10 | |
| 55 ^{+0,08} | 30 ^{H11} | 94 ^{±0,2} | 89,5 ^{-0,2} | 13730 | 16677 | 2600 | 1177 | 13 | 100,0 | 7,6 | 26 | 200,0 | 735 078 | 20 | |
| 70 ^{+0,7} | 50 ^{+0,1} | 60 ^{±0,2} | 60 ^{±0,2} | 11770 | 19620 | - | 1511 | 6,5 | 140,0 | 21,1 | 13 | 270,0 | 735 039 | 10 | |
| 75 ^{-0,5} | 40 ^{+0,2} | 70 ^{±0,5} | 57 ^{-0,5} | 5890 | 4611 | 4510 | 697 | 14 | 130,0 | 9,1 | 28 | 260,0 | 735 038 | 10 | |
| 80 ^{±0,35} | 50 ^{H11} | 100 ^{±0,2} | 95 ^{-0,2} | 14720 | 14715 | 3430 | 1373 | 11 | 260,0 | 23,2 | 22 | 510,0 | 735 083 | 10 | |
| 85 ^{+0,5} | 36 ^{H9} | 102 ^{±0,5} | 85 ^{±0,1} | 6870 | 2943 | 4910 | 598 | 15 | 120,0 | 7,8 | 30 | 240,0 | 735 077 | - | |

Stock items: Available only in standard packages.

All items not marked in blue are listed in the catalogue and can be produced on request. Supply quantities on request.

Supply Programme MEGI® Bushes

Megi AS bushes

Megi AS bushes are produced using the same production methods as Megi HL bushes and therefore have the same superior quality of long life and load capacity. In addition, because of the special design of the outer metal collar, they are able to absorb higher thrust forces without over-stressing the rubber. Because of this property, they are especially suitable for use where high axial forces occur in joints, e.g. in triangular steering linkages (see illustration). No generally valid statements can be made regarding the spring constants for axial loads, because these depend on assembly conditions, especially the magnitude of the initial axial tension.

The maximum continuous and peak loads are given in the table. They apply for highly resilient, particularly durable types of rubbers with a Shore A hardness of approx. 50°.

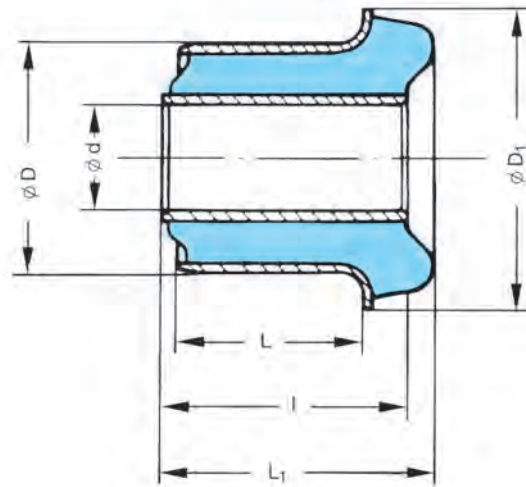

| Dimensions | | | | | | Technical data | | | | | | | Number in package Part No. package | |
|--------------------|--------------------|-----------------|----------------------|------------------------------|----------------------|------------------------|------------------------|----------------------------|-------------------|---------------------------|---------------------------|-----------------------|---------------------------------------|----|
| Outer diameter | Inner diameter | Flange diameter | Length of inner tube | Length of flanged outer tube | Total length of bush | Radial load | | Axial load | | | | | | |
| | | | | | | Max. stat. radial load | Radial spring constant | Max. stat. torsional angle | Max. stat. torque | Torsional spring constant | Max. peak torsional angle | Max. peak torque | | |
| D mm | d mm | D1 mm | l mm | L mm | L1 mm | F _r N | C _r N/mm | ψ degree | M _d Nm | C _ψ Nm/degree | ψ max degree | M _{d,max} Nm | | |
| 30 ^{+0,2} | 14 ^{+0,1} | 41 | 34 ^{±0,25} | 20 ^{+0,2} | 36 | 690 | 1373 | 13 | 7,5 | 0,6 | 26 | 15,0 | 735 048 | - |
| 40 ^{+0,1} | 24 ^{+0,1} | 58 | 42 ^{±0,1} | 30 ^{-0,5} | 45,5 | 3430 | 9810 | 7 | 24,0 | 3,4 | 14 | 48,0 | 735 049 | 20 |

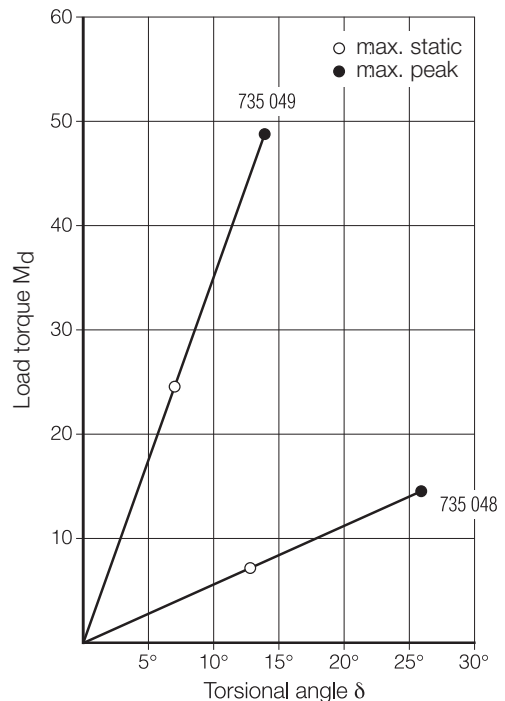
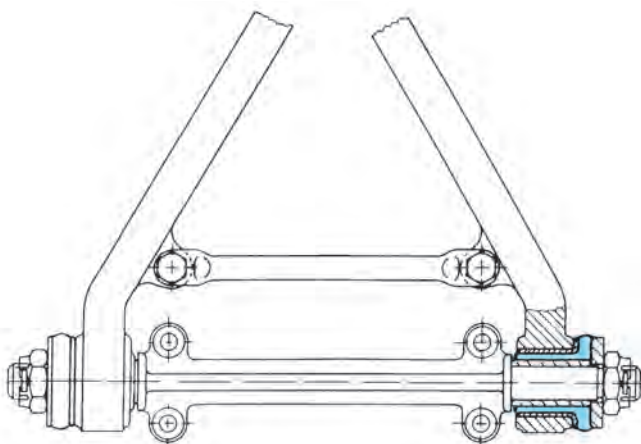

Stock items: Available only in standard packages.
 All items not marked in blue are listed in the catalogue and can be produced on request. Supply quantities on request.

Supply Programme MEGI® Rings

Megi ring Part No. 785 000

Megi rings can be subjected to radial, thrust and torsional loads. When installed, the outside diameter must be precompressed by 1 mm.

Rubber hardnesses:

| | |
|--------|--------------------|
| hard | approx. 70 Shore A |
| medium | approx. 60 Shore A |
| soft | approx. 45 Shore A |

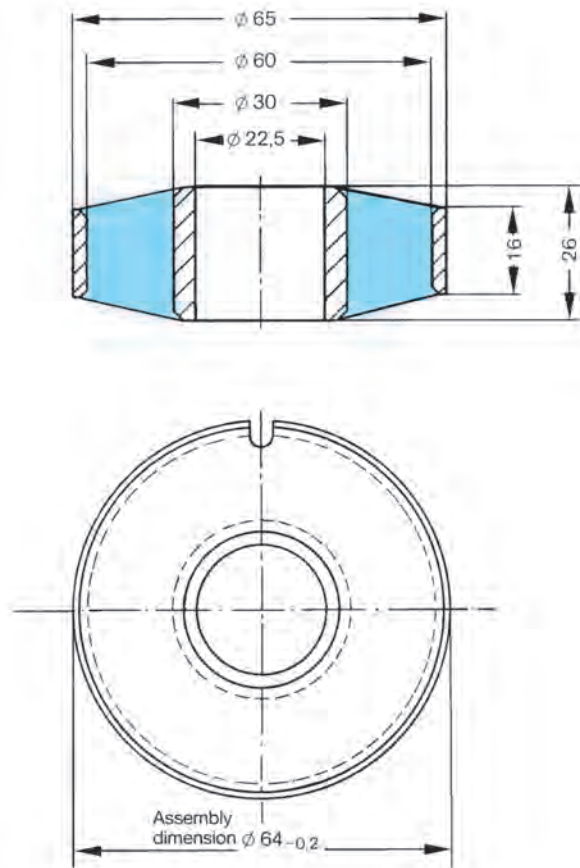

| Technical data | | hard | medium | soft |
|-------------------------------|-----------------------|------|--------|------|
| Permissible stat. radial load | $F_{r\text{zul}}$ [N] | 2200 | 1250 | 600 |
| Radial spring rate | c_r [N/mm] | 980 | 545 | 260 |
| Permissible stat. axial load | $F_{a\text{zul}}$ [N] | 1550 | 900 | 500 |
| Axial spring rate | c_a [N/mm] | 260 | 150 | 80 |
| Permissible stat. torque | M_{zul} [Nm] | 28,4 | 20,6 | 13,7 |
| Torsional spring rate | c_φ [Nm/Grad] | 1,7 | 1,22 | 0,82 |
| Perm. peak torque | M_{max} [Nm] | 57 | 41 | 28 |

Stock items: Available only in packages of 10 each.

All items not marked in blue are listed in the catalogue and can be produced on request. Supply quantities on request.

Materials Information Principles of Calculation

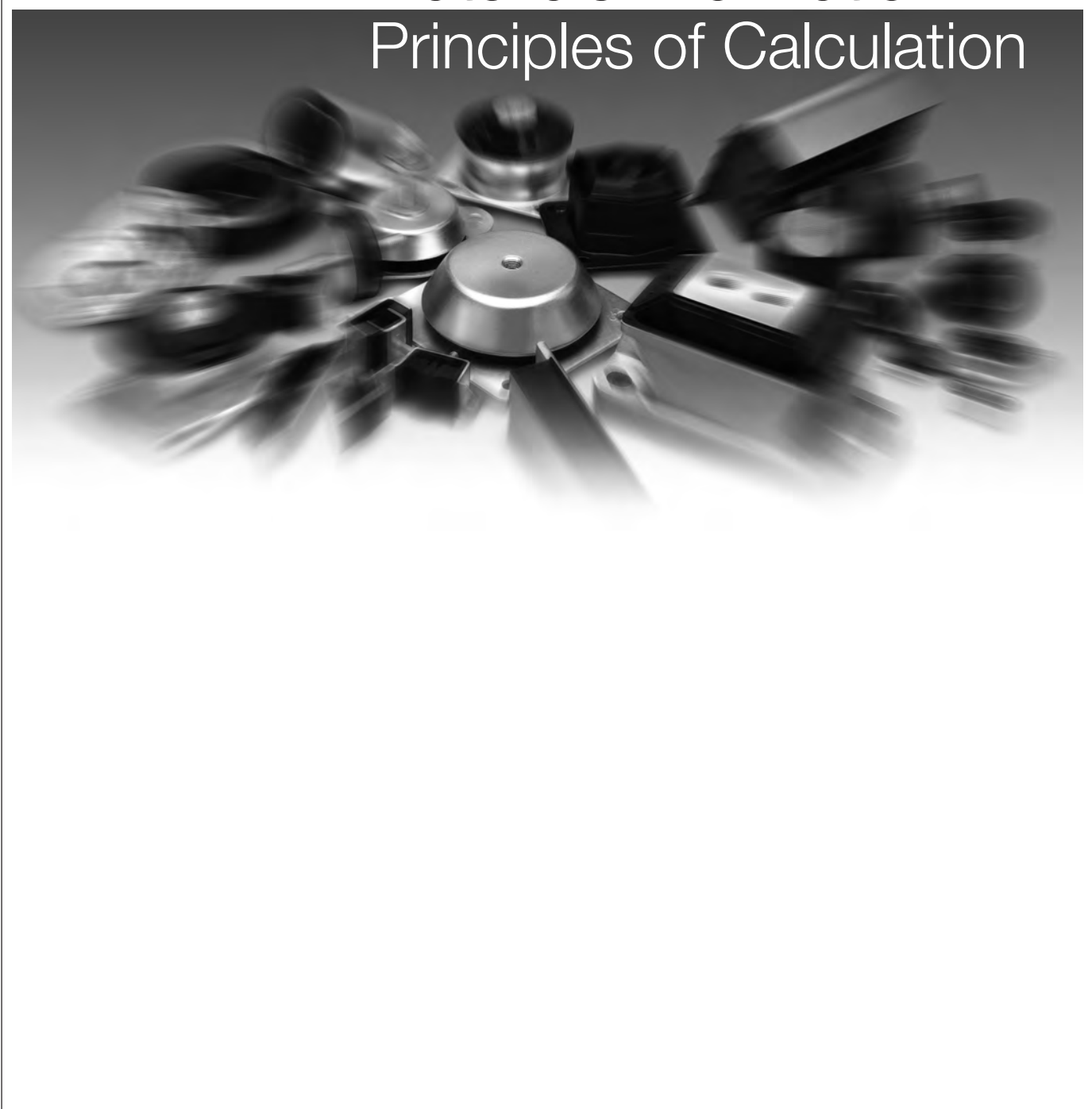

Materials Information



Natural rubber

Natural rubber is the base material for vulcanized products of the highest elasticity and tear resistance. In addition to high notch impact strength, these products have good abrasion resistance and low plastic flow characteristics. Natural rubber has the highest dynamic mechanical load-bearing capacity of all elastomers. Resistance to ozone is only moderate, but can be improved with suitable additives. Natural rubber is not resistant to non-polar liquids such as mineral oils, lubricants, motor fuels and aliphatic, aromatic and chlorinated hydrocarbons.

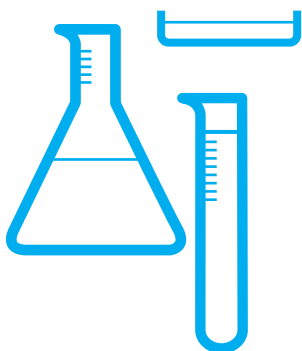

Synthetic rubber

The base material for the manufacture of synthetic rubber is oil or natural gas. In earlier times the manufacture of synthetic rubber as a substitute for natural rubber was encouraged, but increasingly it acquired its own fields of application, for which those properties in which natural rubber is deficient, such as resistance to heat, weathering and oil, were deliberately improved. Thus today there is a whole series of types of synthetic rubber, whose properties have made possible the wide range of applications which have given rubber technology its importance throughout the field of engineering.

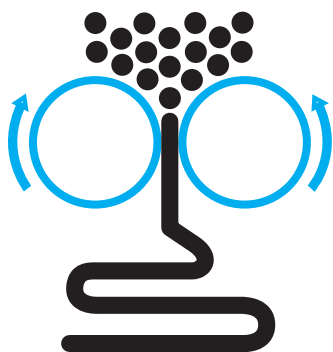

Mixture

Rubber is not a uniform chemical substance, but a mixture of very different materials. Several hundred substances are available for the formulation of a mixture, making it possible to produce different mechanical properties and resistance to various types of degradation. As a macromolecular material caoutchouc is the elastic component in rubber. It determines the level of the mechanical properties such as elongation at break, rebound resilience, strength and tear resistance. It is only after chemicals and additives have been mixed in, followed by vulcanization, that a usable material is produced.

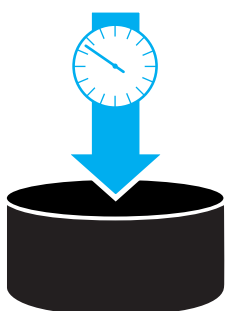

Hardness

This is understood to mean the relative resistance of the surface to a given pressure applied by an indenter of given dimensions. The hardness number represents either the depth of indentation or suitable units derived therefrom, such as Shore hardness (DIN 53505). MEGI-Elements can generally be supplied from stock in three hardness steps (soft, medium, hard). These steps lie tendential in the range of the hardnesses 45, 60, 70 Shore A (Variations are in particular cases possible). Relevant for the execution of the article is the spring characteristics.

Materials Information

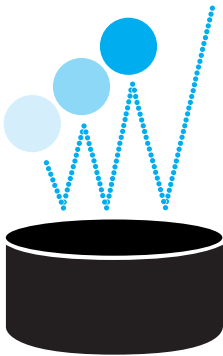

Elasticity

Different degrees of elasticity are found in different unvulcanized rubbers. The elasticity is given in terms of percentage rebound resilience (DIN 53512). High elasticity is equivalent to low damping effect. The natural rubber which is used for MEGl is remarkable for its specially high elasticity compared with synthetic rubbers.

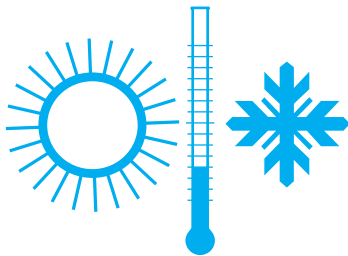

Temperature stability

Vulcanizates made from natural rubber are permanently resistant to temperatures within the limits -40° to $+80^{\circ}\text{C}$ and can withstand temperatures of -60° to $+130^{\circ}\text{C}$ for a short period. These limits can be varied by suitable modifications to the composition of the mixture. It must, however, be borne in mind that changes do not first appear above these limits; they start at lower temperatures but then they take place much more slowly.

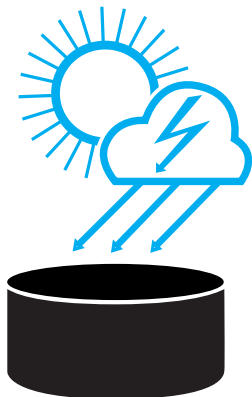

Resistance to ozone

An important property, and one which is the basis for weather resistance, is resistance to ozone (DIN 53 509). Ozone is a modified form of oxygen and occurs in the atmosphere in varying concentrations. When rubber is stretched, attack by ozone produces cracks across the direction of stress. A precondition of the formation of ozone cracks is that the rubber must have been stressed or elongated beyond a certain limit. This limit is generally known as the critical elongation. The speed and extent of this degradation are dependent on the causative conditions and to a large extent on the mixture concerned.

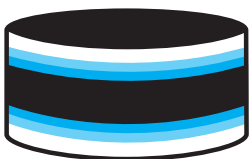

Bonding

In order to bond elastomers to metals, bonding agents are used, usually employing the two-layer system. The two-layer system provides good bond strength and effective protection against under-film rusting. The bonding agents are applied to the clean, grease-free surfaces (mechanical or chemical pretreatment) by brushing on, dipping or spraying and a strong bond between the rubber mixture and the metal is produced by the vulcanization process. The bond strength obtained in this way is normally higher than the resistance to fracture of the elastomer. The absolute tear resistance values depend on the strength of the rubber mixture and the geometry of the article. The finished parts can be electrocoated subsequently without adversely affecting the bond.

Materials Information

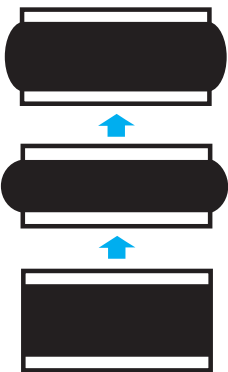

Compression set

It is not possible to avoid permanent deformation of rubber components under load. Under a static load the individual molecular chains slide over each other. This is referred to as “flow” or “creep” (DIN 53444). In the case of dynamic stress the term used is “set”. This compression set is proportional to the logarithm of the time and depends on temperature. It is expressed as a percentage of the static deflection. A compression set of 25 % is usual. As far as compression set is concerned, the performance of MEGI components made with natural rubber is much better than that of comparable components made with synthetic rubber.

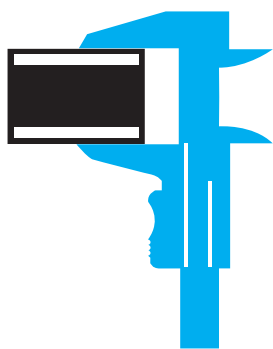

Tolerances

No workpiece can be made exactly to size. The dimensional tolerances are given in the relevant DIN standards. ISO 3302-M3 defines the dimensional tolerances for rubber, DIN ISO 2768 mK for steel. The same applies to the properties of the materials used in the manufacture of rubber components. The hardness can fluctuate by ± 5 points on the Shore scale, and for the spring rate there is a corresponding tolerance zone of $\pm 20\%$. Where technical requirements are especially high, the tolerance zone for the spring rate can be reduced to $\pm 10\%$ by a corresponding expenditure of resources.

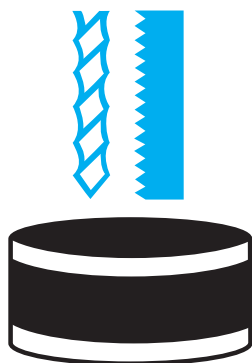

Machining

After vulcanization, rubber parts can be ground, cut and parted off, punched or drilled. It is important to ensure that as little heat as possible is conducted to the adhesion zones during these operations. The cutting operations require high cutting speeds (>1.2 m/s) and good lubrication with soap water.

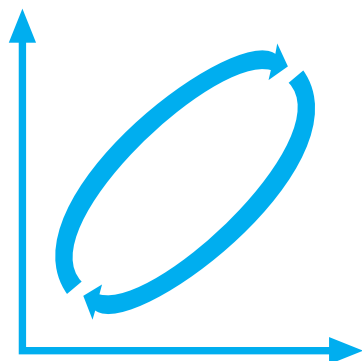

Damping

Damping is the energy lost per oscillation. In vibration engineering the measure of damping is expressed as the mechanical loss angle δ . Damping is not a constant value. It is dependent upon the quality of the rubber, the temperature, the speed of deformation, the shape and the type of stress. For vibration isolation purposes mixtures producing weak damping are mostly used, because they give a better isolation effect when vibration is supercritical.

Materials Information

General material designation

| ASTM Abbreviation | Polymer | Registered trade names |
|-------------------|-----------------------------------|---------------------------|
| NR* IR | Natural rubber Isoprene rubber | Natsyn |
| SBR* | Styrene-butadiene rubber | Buna Hüsl, Polysar S |
| BR | Butadiene rubber | Buna CB |
| IIR | Butyl rubber | Polysar Butyl |
| EPDM | Ethylene propylene terpolymer | Keltan, BUNA AP |
| NBR* | Acrylonitrile butadiene | Perbunan, Chemigum N |
| NBR | Acrylonitrile butadiene (food) | Perbunan, Chemigum N hell |
| ECO | Epichlorohydrin copolymer | Herclor |
| CR | Chloroprene rubber | Baypren, Neoprene |
| CSM | Chlorosulphonated polyethylene | Hypalon |
| AU | Polyurethane rubber | Urepan |
| T | Polysulphide rubber | Thiokol |
| Q | Silicone rubber | Silopren |
| FKM | Fluoro rubber | Viton A, Fluorel |
| ACM | Polyacrylate rubber | Hycar |
| PUR | Polyurethane | Vulkollan |
| PTFE | Polytetrafluorethylene | Teflon, Hostaflon |

* usual qualities for metal-rubber bonds

Summary table

| Properties | NR | IR | SBR | BR | IIR | EPDM | NBR | ECO | CR | CSM | AU | T | Q | FKM | ACM | PUR | PTFE |
|---------------------------------------|-----|-----|------|------|------|------|------|------|------|------|------|------|------|------|------|-----|------|
| Ult. tensile strength, not reinforced | 1 | 2 | 5 | 6 | 4 | 5 | 5 | 5 | 3 | 5 | 2 | 6 | 6 | 5 | 6 | 1 | 1 |
| Ult. tensile strength, reinforced | 1 | 2 | 2 | 4 | 3 | 3 | 2 | 3 | 2 | 3 | 1 | 5 | 4 | 3 | 3 | - | 1 |
| Elongation at break | 1 | 1 | 2 | 3 | 2 | 3 | 2 | 3 | 2 | 3 | 2 | 4 | 4 | 3 | 3 | 2 | 3 |
| Rebound resiliency | 2 | 2 | 3 | 1 | 6 | 3 | 3 | 2 | 3 | 4 | 3 | 4 | 3 | 5 | 5 | 2 | - |
| Abrasion resistance | 2 | 2 | 2 | 1 | 3 | 3 | 2 | 3 | 2 | 3 | 1 | 5 | 5 | 4 | 4 | 1 | 3 |
| Initial tear resistance | 2 | 2 | 3 | 5 | 3 | 3 | 3 | 3 | 2 | 4 | 3 | 4 | 6 | 3 | 4 | 1 | 2 |
| Elec. volume resistivity | 1 | 1 | 2 | 2 | 2 | 2 | 4 | 5 | 3 | 4 | 3 | 3 | 1 | 4 | 4 | 2 | 1 |
| Temperature range hot air °C | +90 | +90 | +100 | +100 | +140 | +150 | +130 | +145 | +120 | +130 | +120 | +140 | +200 | +220 | +160 | +80 | +260 |
| Temperature range cold °C | -50 | -40 | -40 | -60 | -40 | -40 | -40 | -40 | -30 | -40 | -20 | -30 | -80 | -25 | -20 | -35 | -190 |
| Ageing resistance | 3 | 3 | 3 | 3 | 2 | 1 | 3 | 2 | 2 | 2 | 2 | 3 | 1 | 1 | 2 | 1 | 1 |
| Resistance to ozone | 4 | 4 | 4 | 3 | 2 | 1 | 3 | 2 | 2 | 2 | 2 | 2 | 1 | 1 | 2 | 1 | 1 |
| Resistance to petrol | 6 | 6 | 4 | 5 | 6 | 5 | 1 | 1 | 2 | 2 | 1 | 1 | 5 | 1 | 1 | 2 | 1 |
| Resistance to oil and grease | 6 | 6 | 5 | 6 | 6 | 4 | 1 | 1 | 2 | 2 | 1 | 1 | 1 | 1 | 1 | 2 | 1 |
| Resistance to acids | 3 | 3 | 3 | 3 | 2 | 1 | 4 | 5 | 2 | 2 | 5 | 4 | 5 | 1 | 5 | 6 | 1 |
| Resistance to alkalis | 3 | 3 | 3 | 3 | 2 | 2 | 3 | 5 | 2 | 2 | 5 | 3 | 5 | 1 | 5 | 6 | 1 |
| Hot water | 3 | 3 | 2 | 3 | 1 | 2 | 3 | 4 | 3 | 3 | 5 | 3 | 5 | 2 | 5 | 6 | 1 |

1 = excellent 2 = very good 3 = good 4 = moderate 5 = slight 6 = poor

Materials Information

1. General Material Characteristics

| | | |
|---|------------|------------|
| Density | DIN 53 479 | DIN 53 550 |
| Hardness | DIN 53 505 | |
| Ultimate tensile strength and elongation at break | DIN 53 504 | DIN 53 455 |
| Shock elasticity (Rebound resilience) | DIN 53 512 | |
| Damping | | |
| - Dynatron | DIN 53 513 | |
| Compression set | DIN 53 517 | |
| Tension set | DIN 53 518 | |

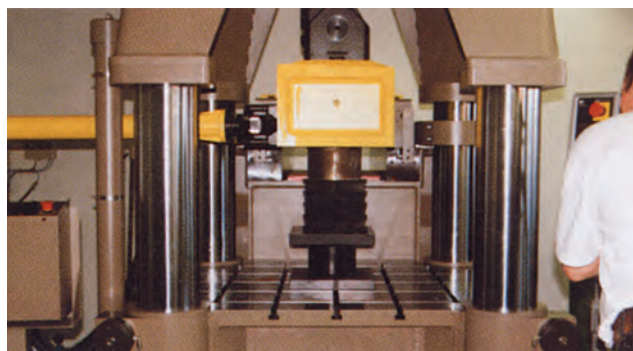

3-Axle test stand for static and dynamic measurements

2. Stress-Strain Characteristics

2.1 Destructive tests

| | | |
|---|------------|------------|
| Ultimate tensile strength and elongation at break | DIN 53 504 | DIN 53 455 |
| - Strip specimen | DIN 53 507 | |
| - Angle specimen | DIN 53 515 | |
| - Tear resistance (needle test) | DIN 53 506 | |

2.2 Moduli

| | | |
|--|------------|------------|
| Tension and compression elastic modulus | | |
| - Static | DIN 53 457 | |
| - Dynamic | DIN 53 513 | |
| Modulus in flexure (static) | DIN 53 457 | |
| Shear modulus (Torsion oscillation test) | DIN 53 520 | DIN 53 445 |

Stiffness in torsion (relative shear modulus)

| | |
|--------------|-------------|
| - Clash-Berg | DIN 53 447 |
| - Gehmann | ASTM D 1053 |

2.3 Indentation hardness (material hardness)

| | |
|---|---------------|
| - Shore hardness | DIN 53 505 |
| - Ball indentation hardness (IRHD) | DIN 53 519 |
| - Indentation hardness (hardness number) | DIN 53 576 |
| - Ball indentation hardness (Pusey & Jones) | ASTM D 531-56 |

3. Permeation Characteristics

| | |
|---------------------------|-----------------------|
| Water vapour permeability | DIN 53 122 |
| Water tightness | DIN 53 886 |
| Gas permeability | DIN 53 536 DIN 53 380 |

4. Resistance to Solids

| | |
|---|-----------------------|
| Coefficient of friction (Tannert apparatus) | |
| Adhesive strength | DIN 53 530 DIN 53 531 |



Computer supported documentation for release of the raw material

5. Continuous Stress

| | |
|------------------------------|-----------------------|
| Creep | DIN 53 444 |
| Restoring force (relaxation) | DIN 53 441 |
| Compression set | DIN 53 517 DIN 53 572 |
| Tension set | DIN 53 518 |

Continuous wear

(Destruction through heat build-up)

| | |
|------------------------|---------------|
| - Martens ball fatigue | |
| - St. Joe flexometer | ASTM D 623-62 |

Fatigue

(Destruction through crack initiation and growth)

| | |
|------------------------------|------------|
| - Tensile fatigue | ASTM D 430 |
| - Flex cracking (De Mattia) | DIN 53 522 |
| - DIN abrasion test | DIN 53 516 |
| - Frank-Hauser | DIN 53 528 |
| - Taber apparatus | DIN 53 754 |
| - Egner apparatus | DIN 51 963 |
| - Abrasion tester (Schopper) | DIN 53 863 |

Materials Information

6. Properties under extreme temperatures

(Limits of usability)

Low temperature properties

- Low temperature standards (dyn. brittle point)
- Brittle point (glass transition temperature)

High temperature properties

- Resistance to glow heat DIN 53 459
- Nonflammability DIN 53 438 DIN 53 382
- ASTM D 1692 ASTM D 635
- DIN 22 103

7. Thermal Characteristics

- Heat conductivity DIN 52 612
- Coefficient of thermal expansion DIN 53 328

8. Electrical Characteristics

- Volume resistivity DIN 53 482 DIN 53 596
- Surface resistance DIN 53 482 DIN 53 596
- DIN 53 486
- Creep resistance DIN 53 480
- Dielectric strenght DIN 53 481
- Relative permittivity DIN 53 483
- Dielectric loss factor DIN 53 483

9. Resistance to Chemicals (Swelling)

- Changes in physical properties DIN 53 521 DIN 53 476

10. Resistance to Gases and Vapours

- Resistance to ozone DIN 53 509
- Resistance to oxygen
- Geer aging DIN 53 508
- Bierer aging DIN 53 508
- Compressed-air bomb DIN 53 508
- Air-steam resistance (Resistance to hydrolysis)
- Air-steam chamber DIN 53 508
- Dessicator DIN 53 473
- Steam sterilizer
- Environmental chamber

11. Light Fastness

- Sunlight DIN 53 388
- Artificial light DIN 53 388 DIN 53 389

12. Resistance to Organisms

- Microbes DIN 53 930 DIN 53 931

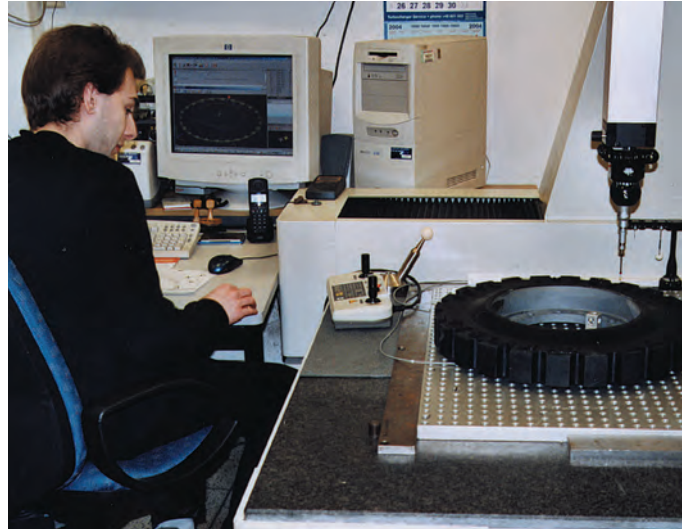

Testing metal part in receiving department



Rigidity test on MEGI component

Mode of Operation



Vibration Isolation

Through the interplay of inertia and restoring force, the total mass of a machine and the spring rate of the Megi elastic rubber springs determine the natural frequency of the machine on its bearing; i.e. a single impact on the machine produces vibration of decreasing amplitude at the natural frequency. In the case of forced vibrations caused, for example, by eccentric weights on rotating masses, or by periodic stroke movements, the machine on its bearing always vibrates at this exciting frequency. Vibration isolation can only be achieved if the design is such that the natural frequency is less than the exciting frequency by a factor of $\sqrt{2}$. This is achieved by a suitable selection of Megi spring elements of the appropriate spring rate.

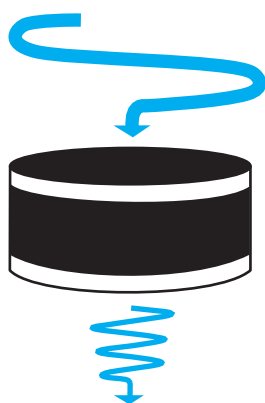

Sound Insulation

Sound waves are mechanical vibrations which are transmitted from one body to another through rigid connections (structure-borne sound). Rubber is a very good medium for insulating structure-borne sound. For that reason Megi elements are excellent sound insulators.



Impact and Shock Insulation

Impact and shock subject the bearing elements momentarily to the application of high kinetic energy. This energy is converted to work in the spring elements: the highest permissible values of the applied force can be two to three times as great as the permissible static load. The energy absorption of a spring element is given by the area under the load-deflection curve, which can be obtained by measuring with a planimeter.

Types of Stress

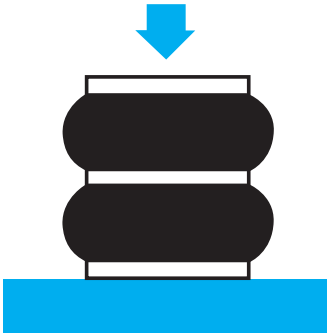

Compression

When a rigidly-sprung seating is required and heavy loading occurs, Megi elements for compression loads are used. The strength of the springs is not determined by the compressive stress, but by the shear stress which occurs by the prevention of lateral expansion in the individual layers. The stress is highest at the outer adhering edges. In order to obtain reduced spring deflection with the same load, multi-layer springs are used with intermediate plates bonded by vulcanization. Up to about 15 % compression the spring rate is linear but thereafter it becomes steeply progressive.

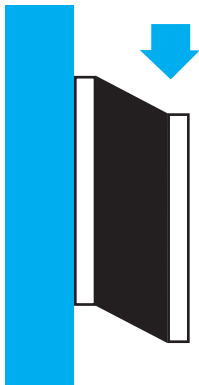

Shear

When large spring deflection is required for loads of medium weight, Megi elements for shearing stress are used. Where only shearing stress occurs, the load-deflection diagram is linear. If the rubber elements between the metal parts are high in relation to their cross-section, additional undesirable bending stress can occur, which gives a degressive load-deflection curve and adversely affects the service life.

Compression-Shear

Megi elements for compressive and shearing stress are used for heavy to medium loads where large spring deflection is required. This can be achieved by pairs of elements set at an angle to each other or by wedge- and cone-type bearings. The compression-shear stress distribution is completely uniform in the rubber, especially in wedge-type bearings, so that harmful bending stress can be avoided.

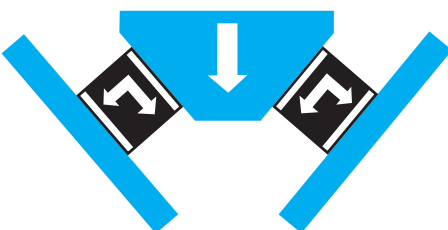

Types of Stress

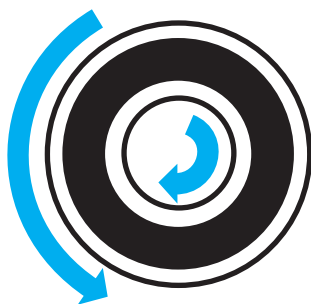

Torsion-Shear

Megi bushes are used as torsion springs in industrial applications for the elastic absorption of torque. If the outer tube turns in relation to the inner tube, shearing stress occurs in the rubber. The thicker the rubber cushion between the inner and outer tubes, the less is the torsional stiffness of the bush.



Tension

If a solid piece of rubber with metal plates vulcanized on to the ends is subjected to tension, waisting of the central section occurs because the volume remains constant. Harmful stressing occurs, particularly at the edges of the metal parts, and if the stressing is dynamic, it will reduce the life of the component considerably. This can be alleviated by using rubber elements with a constricted central part and an enlarged area where the bond occurs. Nevertheless, tensile stress should be avoided as far as possible.

Possibilities for Problem Solving

Choice of appropriate MEGI®-Spring elements
for your bearing applications

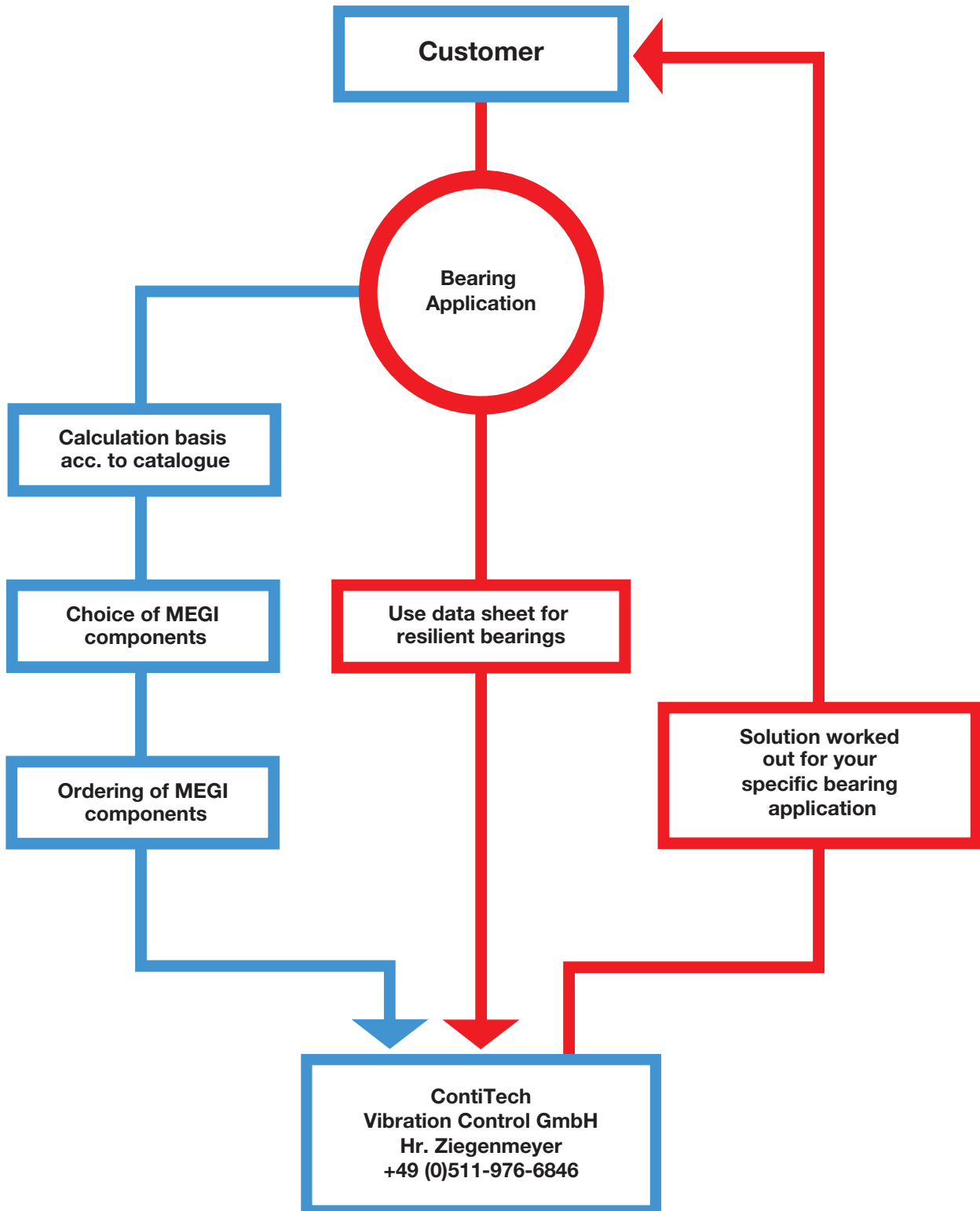

Basis of Calculation

Formula symbols

The formula symbols used are those specified in DIN 1304. Any terms not listed in that standard are represented by the letters normally used by ContiTech. The units are those employed in the International System of Units (SI).

Common Abbreviations

| Abbrev. | Meaning |
|---------|---------------|
| D | compression |
| S | shear |
| V | torsion |
| Kard | cardanic |
| e | self |
| err | exciter |
| stat | static |
| dyn | dynamic |
| st | impact, shock |
| ges | total |
| zul | permissible |
| x | lengthwise |
| y | crosswise |
| z | vertical |

| Symbol | Unit | Meaning |
|----------------|-----------------------------------|--|
| F | N, kN | force |
| m | kg | mass |
| a | m/s ² | acceleration |
| g | 9,81 m/s ² | accel. due to gravity |
| G | N, kN | weight |
| f | Hz = 1/s | frequency |
| n | 1/min | rotational speed |
| c | N/m, N/mm | spring rate |
| c _v | Nm/degree | torsional spring rate |
| η | 1 | frequency ratio |
| i | % | degree of insulation |
| s | mm, m | spring deflection |
| φ | degree | torsion angle |
| γ | degree | shear angle |
| δ | degree | loss angle |
| M | Nm, Nmm | moment |
| W | J = Nm = Ws | absorption of work |
| E | J = Nm = Ws | energy |
| P | W | performance |
| p | Ns = Kgm ² /s | pulse |
| ε | % | compression set |
| A | mm ² , cm ² | area |
| v | m/s | velocity |
| α | degree | angle of incidence |
| D | 1 | attenuation constant |
| D | dB | structure-borne sound insulation value |

Determination of direction of load on MEGI® spring elements

In most cases a bearing arrangement is necessary with different spring rates for the various directions of the applied load. In order to set out clearly the directions of the applied forces and deformations, these are indicated as the x, y and z directions as in Fig. 6.

Accordingly the spring rates for the various directions are designated as c_x, c_y and c_z.

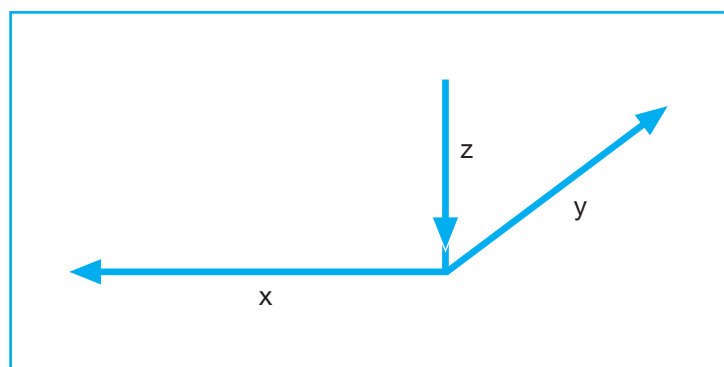

Fig. 6

Basis of Calculation

Determination of the spring rate from a load-deformation diagram

If a force F or a moment M acts on a Megi spring element, the element is deformed by a spring deflection s or by a torsion angle ϕ . A distinction is made between progressive, linear and degressive load-deformation curves. It is only when the curve is linear that the spring rate c , or, in the case of torsion c_v , is constant over the complete range of spring deflection. In the other two cases the spring rate c is dependent upon the degree of deformation. The method of determining the spring rate in each case is shown in the summary (Fig. 7).

The distance s_{subA} or ϕ_{subA} is obtained by projecting the tangent at point A for the given load F_A or torque M_A on to the x-axis. The spring rate at point A obtained by dividing the load at point A by the distance so obtained.

| Spring rate | Spring rate at working point A | Load-deformation diagram |
|--|---|--|
| $c = \frac{dF}{ds}$ $c_v = \frac{dM}{d\phi}$ | $c_A = \frac{F_A}{s_{subA}}$ $c_{\phi} = \frac{M_A}{\phi_{subA}}$ | <p style="text-align: right;">progressive</p>  |
| $c = \frac{F}{s}$ $c_v = \frac{M}{\phi}$ | $c_A = \frac{F_A}{s_A}$ $c_{\phi} = \frac{M_A}{\phi_A}$ | <p style="text-align: right;">linear</p>  |
| $c = \frac{dF}{ds}$ $c_v = \frac{dM}{d\phi}$ | $c_A = \frac{F_A}{s_{subA}}$ $c_{\phi} = \frac{M_A}{\phi_{subA}}$ | <p style="text-align: right;">degressive</p>  |

Fig. 7

Possible arrangements of MEGI® elements

Parallel arrangement:

$$\text{Deflection: } s = \frac{F}{c_{ges}} = \frac{F}{c_1 + c_2 + c_3 + c_4}$$

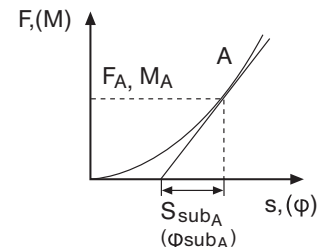
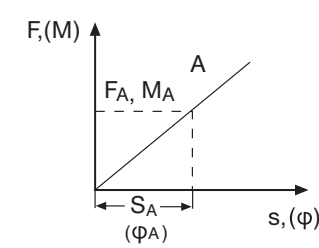
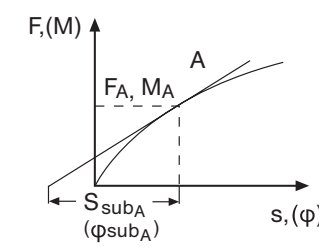
$$\text{Spring rate: } c_{ges} = c_1 + c_2 + c_3 + c_4$$

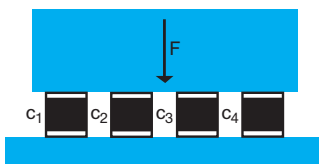

Serial arrangement:

$$\text{Deflection: } s = \frac{F}{c_{ges}} = \frac{F}{c_1} + \frac{F}{c_2} + \frac{F}{c_3} + \frac{F}{c_4}$$

$$\text{Spring rate: } \frac{1}{c_{ges}} = \frac{1}{c_1} + \frac{1}{c_2} + \frac{1}{c_3} + \frac{1}{c_4}$$

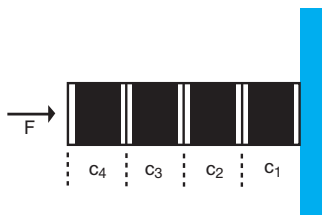

Set at an angle:

$$\text{Deflection: } s = \frac{F_z}{c_z}$$

$$\text{Spring rate: } c_z = 2 \cdot (c_D \cos^2\alpha + c_S \sin^2\alpha)$$

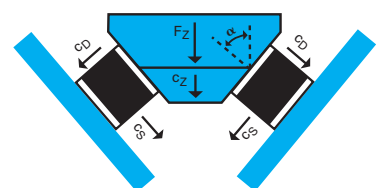

If four or six springs are used, the factor 2 in the formula is changed to 4 or 6.

Basis of Calculation

Directions for calculations for uniform stressing of MEGI® elements

An elastic bearing arrangement should be assembled in such a way that spring deflection is equal at all bearing points. In a torsionally stiff system this requirement is met when the sum of the products of resilience value and respective distance from the centre of gravity is the same on both sides of the centre of gravity.

Calculation of distribution of the MEGI® elements x, y [mm] G, F_A, F_B, F_C, F_D [N]

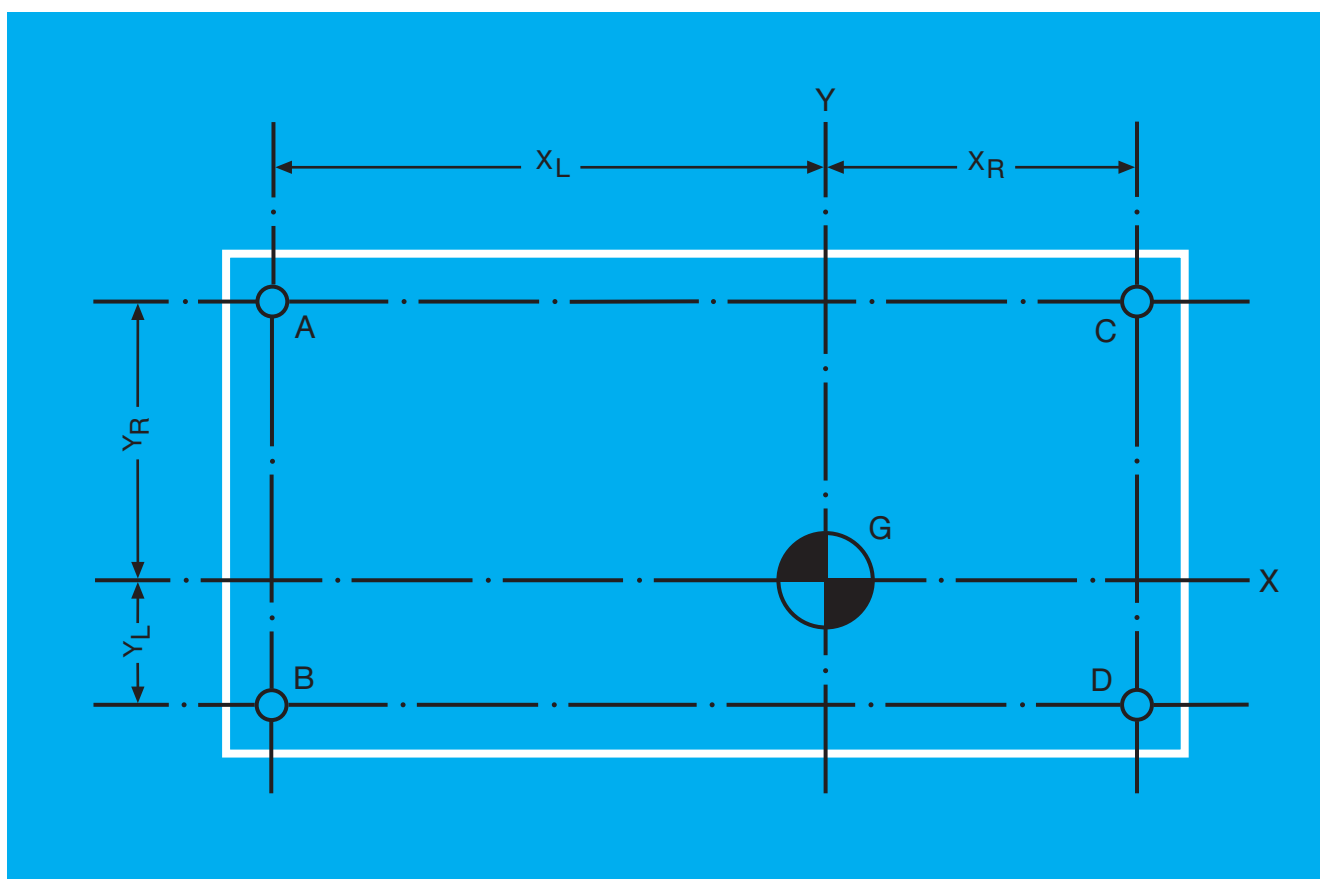

Fig. 8

Supporting forces F_A, F_B, F_C, F_D

Calculation of the point loads at specified mounting points with non-symmetrical position of centre of gravity.

$$F_A = \frac{G \cdot X_R}{X_R + X_L} \cdot \frac{Y_L}{Y_R + Y_L} \quad F_B = \frac{G \cdot X_R}{X_R + X_L} \cdot \frac{Y_R}{Y_R + Y_L}$$

$$F_C = \frac{G \cdot X_L}{X_R + X_L} \cdot \frac{Y_L}{Y_R + Y_L} \quad F_D = \frac{G \cdot X_L}{X_R + X_L} \cdot \frac{Y_R}{Y_R + Y_L}$$

Basis of Calculation

Isolation of vibration from periodic excitation

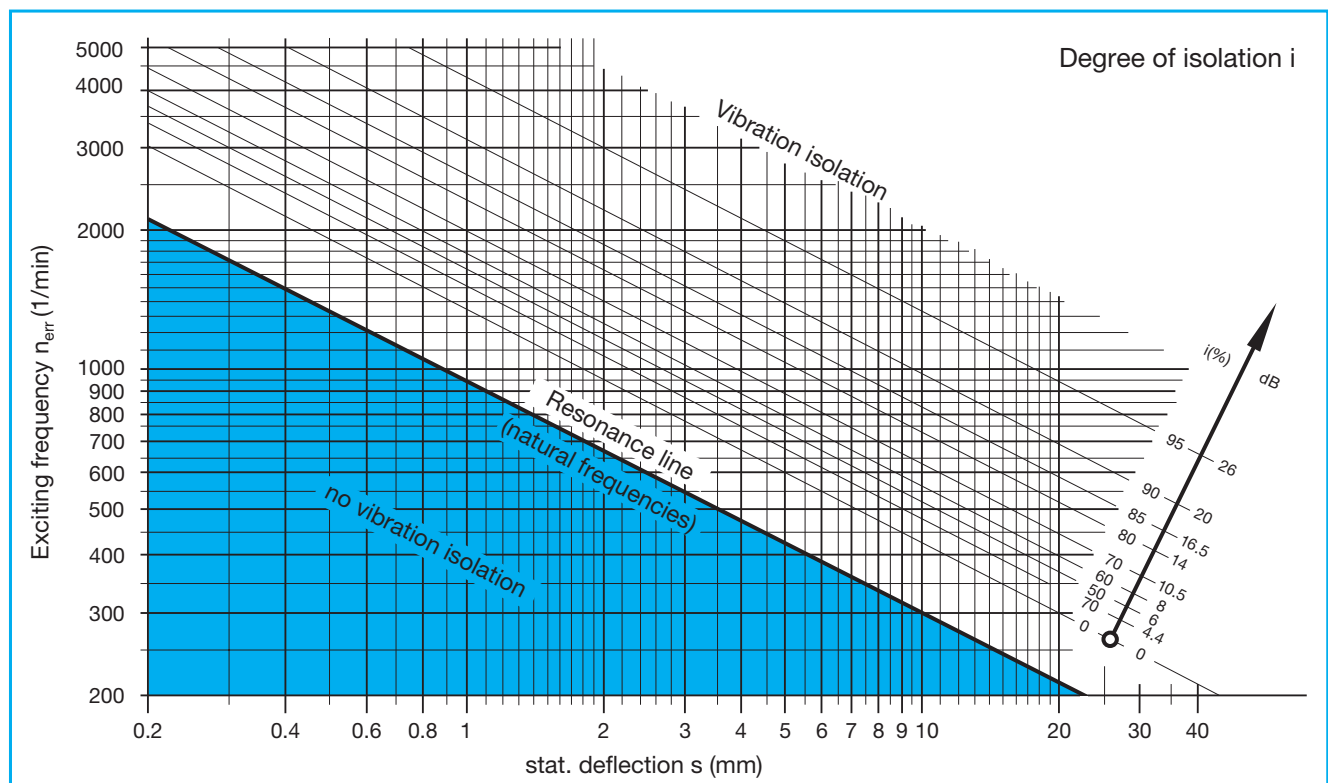
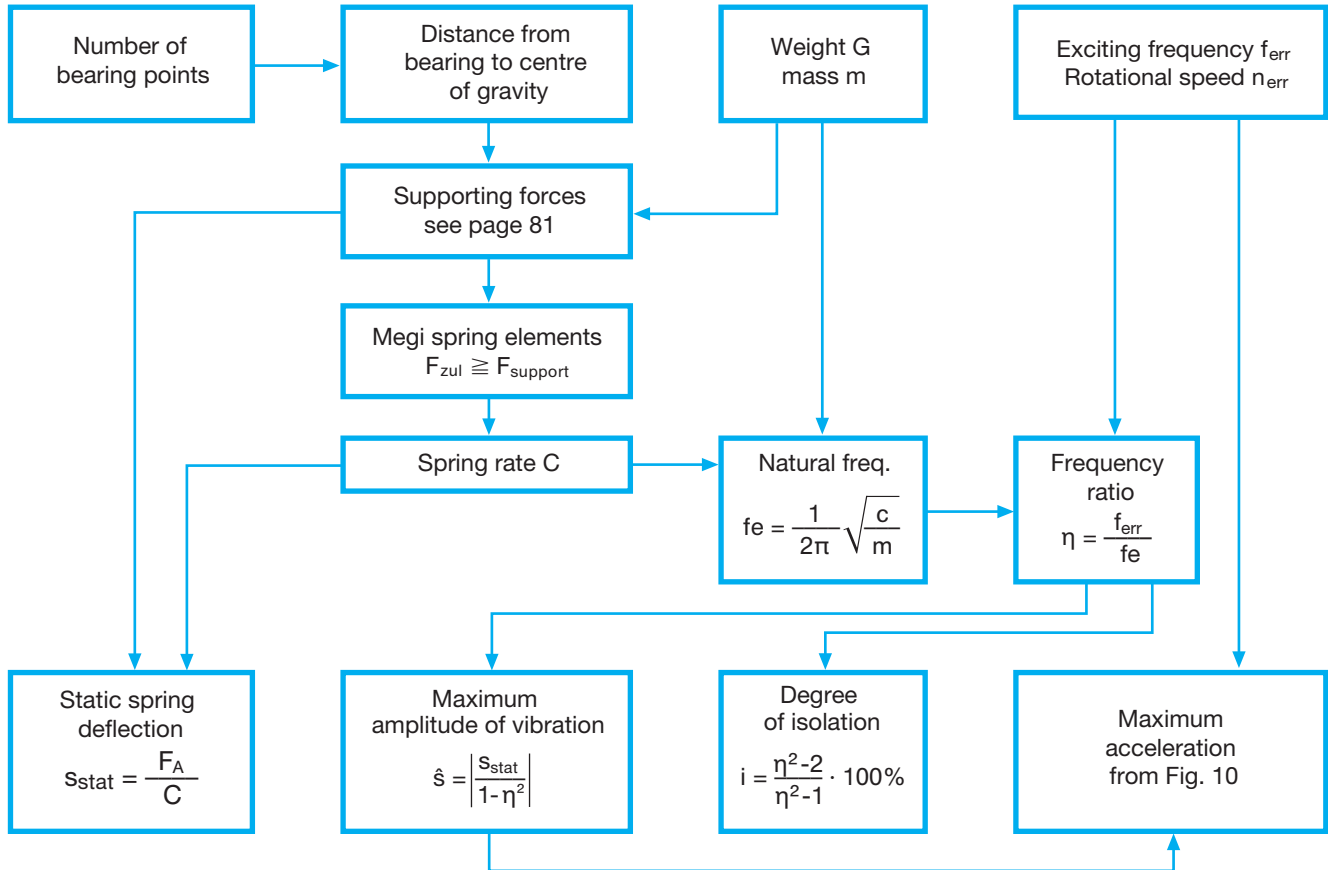

Fig. 9

Basis of Calculation

Shock and impact isolation

Reaction to a rectangular impact of an univariant elastic bearing with linear characteristic.

Input data: Acceleration due to gravity $g \geq 9.81 \text{ m/s}^2$
 Mass m (kg); acceleration a_e [m/s^2];
 Impact duration t_{st} [s] or class of shock according to Federal Ministry of Building, e.g. RK 0.63/6.3

Kinetic energy of excitation: $E_{kin} = \frac{1}{2} mv^2$ [Nm]

Energy absorbed by MEGI element: $E_A \approx \frac{4 \cdot F_{zul}^2}{c_{dyn}}$ [Nm] or measure area under spring characteristic

Strength check: $E_{kin} \leq E_A$ or $F_{zul} \geq \sqrt{\frac{c_{dyn} \cdot E_{kin}}{4}}$ [N]

Selection of the MEGI®-element



Dynamic spring rate: $c_{dyn} \approx 1,2 \cdot c$ [N/m]

Static deflection: $s_{stat} = \frac{m \cdot g}{c}$ [m]

Natural frequency: $f_e = \frac{1}{2\pi} \cdot \sqrt{\frac{g}{s_{stat}}}$ [Hz]

Net acceleration: $a_r = \frac{a_e \cdot t_{st}}{\sqrt{\frac{s_{stat}}{g}}}$ [m/s^2]

Vibration amplitude: $\hat{s} = \frac{a_r}{(2\pi f_e)^2}$ [m]

Static deflection at given net acceleration: $s_{stat} = g \cdot \left(\frac{a_e}{a_r} \cdot t_{st}\right)^2$ [m]

Basis of Calculation

Fig 10
Relationship between amplitude, frequency and acceleration

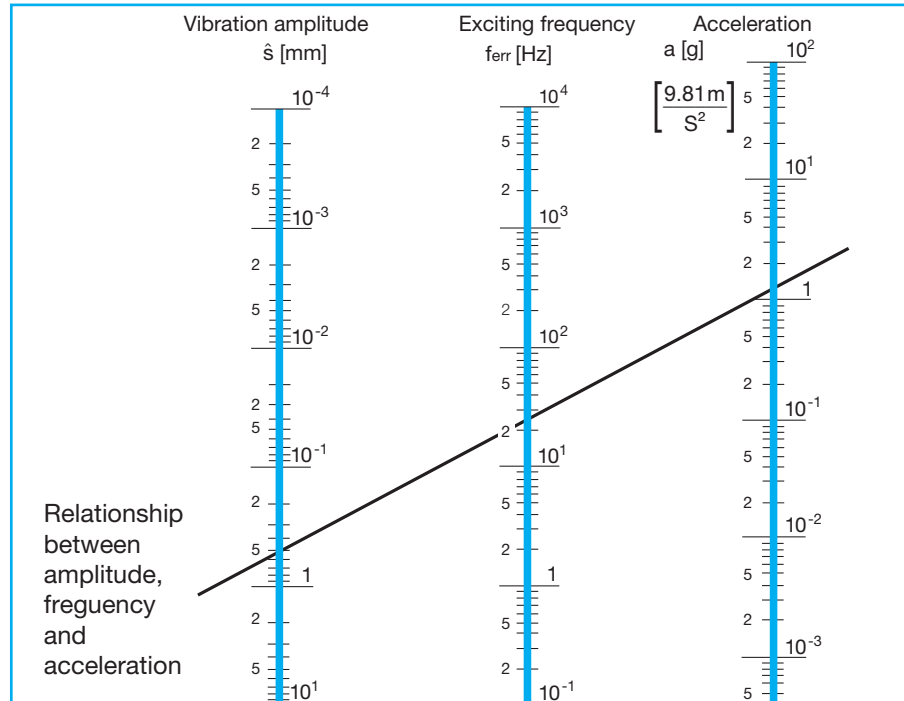
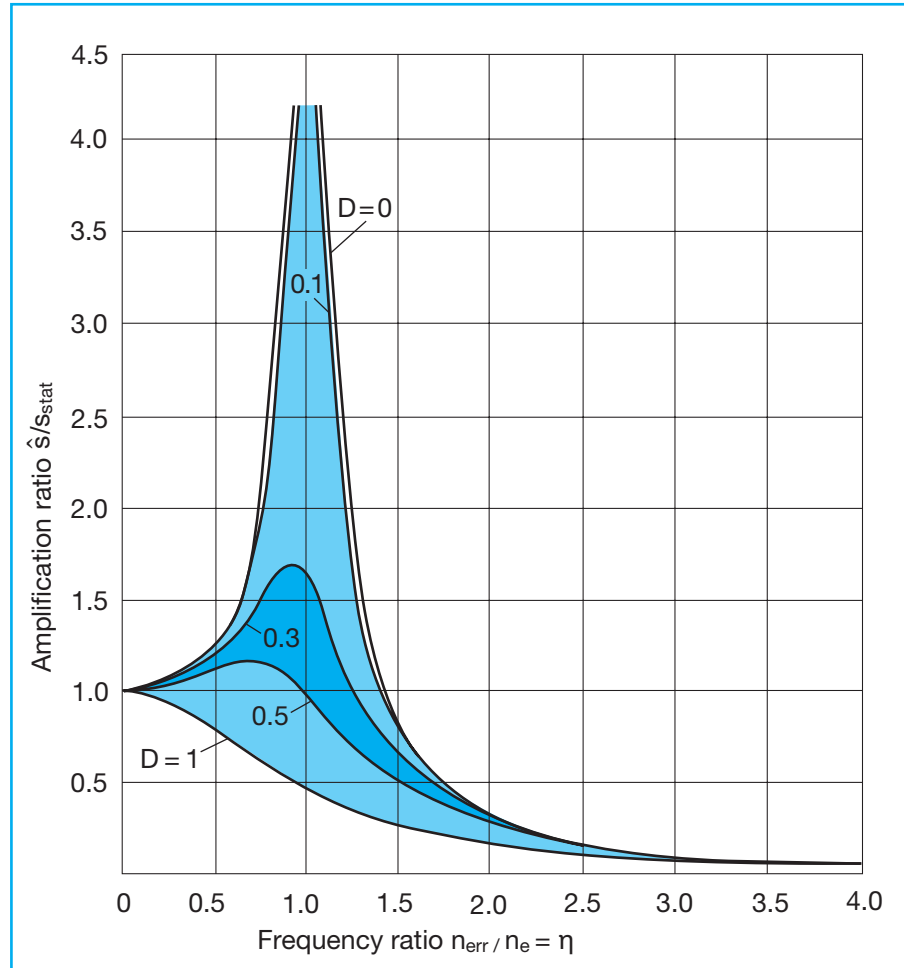

Fig 11
Relationship between amplification ratio for vibration amplitude \hat{s}/s_{stat} and frequency ratio n_{err}/n_e at various values of damping D .
 \hat{s} greatest vibration amplitude
 s_{stat} static deflection
 n_{err} rotational speed of exciter
 n_e natural frequency

$$\frac{\hat{s}}{s_{stat}} = \frac{1}{\sqrt{(1-\eta^2)^2 + 4D^2\eta^2}}$$

If $D = 0$:

$$\frac{\hat{s}}{s_{stat}} = \left| \frac{1}{1-\eta^2} \right|$$



Example of Calculation

A machine unit with a total weight of 30 kN and with an exciter system, a part rotating at $n_{err} = 1450$ r.p.m., is to be erected so that the vibration is isolated. 4 bearing points are provided. The position of the centre of gravity is non-symmetrical.

Outline sketch:

Given:

Weight $G = 30$ kN,
Exciter speed $n_{err} = 1450$ r.p.m.,
No. of bearing points: 4
Distance of bearing points from centre of gravity: Sketch

Required:

Supporting forces, Megi spring elements, spring rate, static deflection, natural frequency, frequency ratio, degree of isolation, damping value for structure-borne sound, maximum vibration amplitude, maximum acceleration of the machine.

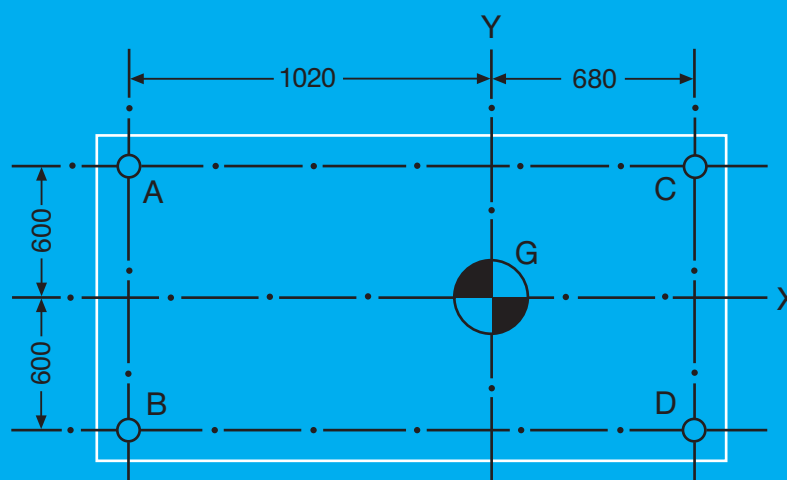

Solution

1. Supporting forces: F_A , F_B , F_C , F_D

The supporting forces are determined in accordance with the directions for calculations for uniform stressing of Megi elements (page 15).

$$F_A = F_B = \frac{30 \text{ kN} \cdot 680}{680 + 1020} \cdot \frac{600}{600 + 600} = 6 \text{ kN}$$

$$F_C = F_D = \frac{30 \text{ kN} \cdot 1020}{680 + 1020} \cdot \frac{600}{600 + 600} = 9 \text{ kN}$$

2. MEGI spring elements

The Megi machine base support 786011 is selected from the load-deformation diagrams or from the tables. The "hard" quality, which has a deflection of 3 mm at a loading of 9 kN, is selected for the right-hand bearings and the medium quality, with a deflection of 3 mm at a loading of 6 kN, is selected for the left-hand bearings.

3. Spring rate: c

For the Megi machine base support 786011 the spring rate is

$$\text{medium } c = \frac{F_A}{s_{\text{stat}}} \cdot \frac{6000 \text{ N}}{0.003 \text{ m}} = 2 \cdot 10^6 \text{ N/m} = c_{A,B} \text{ and}$$

$$\text{hard } c = \frac{F_C}{s_{\text{stat}}} \cdot \frac{9000 \text{ N}}{0.003 \text{ m}} = 3 \cdot 10^6 \text{ N/m} = c_{C,D}$$

Example of Calculation

4. Static deflection: s_{stat}

The spring elements are arranged in parallel.

The total spring rate is therefore

$$c_{total} = 2 c_{A,B} + 2 c_{C,D} = 2 \cdot 2 \cdot 10^6 \text{ N/m} + 2 \cdot 3 \cdot 10^6 = 10 \cdot 10^6 \text{ N/m}.$$

Accordingly the total static deflection is

$$s_{stat} = \frac{G}{c_{ges}} = \frac{30000 \text{ N}}{10 \cdot 10^6 \text{ N/m}} = 0.003 \text{ m}$$

5. Natural frequency: f_e

The natural frequency of the machine on flexible bearings is calculated from the formula

$$f_e = \frac{1}{2\pi} \sqrt{\frac{c_{total}}{m}} \text{ [Hz]} \text{ where mass } m = \frac{G}{g} \text{ [kg]}$$

The natural frequency is therefore

$$f_e = \frac{1}{2\pi} \sqrt{\frac{9.81 \cdot 10 \cdot 10^6}{30000}} = 9.1 \text{ Hz}$$

6. Frequency ratio: η

$$\eta = \frac{f_{err}}{f_e}, \text{ where } f_{err} = \frac{n_{err}}{60} \text{ Hz}$$

In this example the frequency ratio is

$$\eta = \frac{1450}{60 \cdot 9.1} = 2.66$$

7. Degree of isolation: i

Given the exciter speed n_{err} and the static deflection s_{stat} , the degree of isolation can be read from Fig. 9, or it can be calculated from the formula

$$i = \frac{\eta^2 - 2}{\eta^2 - 1} \cdot 100\% = \frac{2.66^2 - 2}{2.66^2 - 1} \cdot 100\% = 83.54\%$$

It can be seen from the above that only 16.5% of the vibrational forces generated by the machine are transmitted to the base.

8. Structure-borne sound insulation value: D

As with the degree of isolation, the insulation value for structure-borne sound can be read directly from Fig. 9 or it can be calculated from the formula

$$D = 20 \cdot \lg \frac{1}{1-i} = 20 \cdot \lg \frac{1}{1-0.8354} = 15.67 \text{ dB}$$

In this formula the degree of isolation i is not entered as a percentage.

9. Maximum vibration amplitude: \hat{s}

The maximum vibration amplitude can be taken from Fig. 11 or can be calculated from the formula

$$\hat{s} = \frac{s_{stat}}{1-\eta^2} = \frac{0.003}{1-2.66^2} = 0.00049 \text{ m}$$

9. Maximum acceleration: a_{max}

The maximum acceleration can be taken from Fig. 10 or can be calculated from the formula

$$a_{max} = \hat{s} \cdot (2\pi \cdot f_{err})^2 = 0.00049 \cdot \left(2\pi \cdot \frac{1450}{60}\right)^2 = 11.3 \text{ m/s}^2$$

i.e. the maximum acceleration of the machine is 1.15 g.

www.contitech.de
www.contitech-megi.de



Vibration Control

Market segment
Vibration Control Industry

Your local contact:

Autorizovaný distributor pro ČR a SR



TYMA CZ, s.r.o.

Na Pískách 731
CZ - 400 04 Trmice
Phone +420 475 655 010
Fax +420 475 655 018
Email info@tyma.cz
www.tyma.cz

www.contitech.de/contactlocator

The ContiTech division of the Continental Corporation is a development partner and original equipment supplier to numerous industries for high-quality functional parts, components and systems. With its know-how in rubber and plastics technology, ContiTech contributes significantly to industrial progress and mobility that is safe, comfortable and eco-friendly.

Certification



VDA 6.1
041 018005



QS-9000
041 018005



EN ISO 9001
041 018005



Umweltmanagementsystem
EN ISO 14001
041 018005

The content of this publication is not legally binding and is provided as information only. The trademarks displayed in this publication are the property of Continental AG and/or its affiliates. Copyright © 2012 ContiTech AG. All rights reserved. For complete information go to: www.contitech.de/disclosure