

Hydrodynamic couplings TK-N

KWN 29000



Couplings from Germany
By specialists – for specialists



řemeny, převody a lineární technika

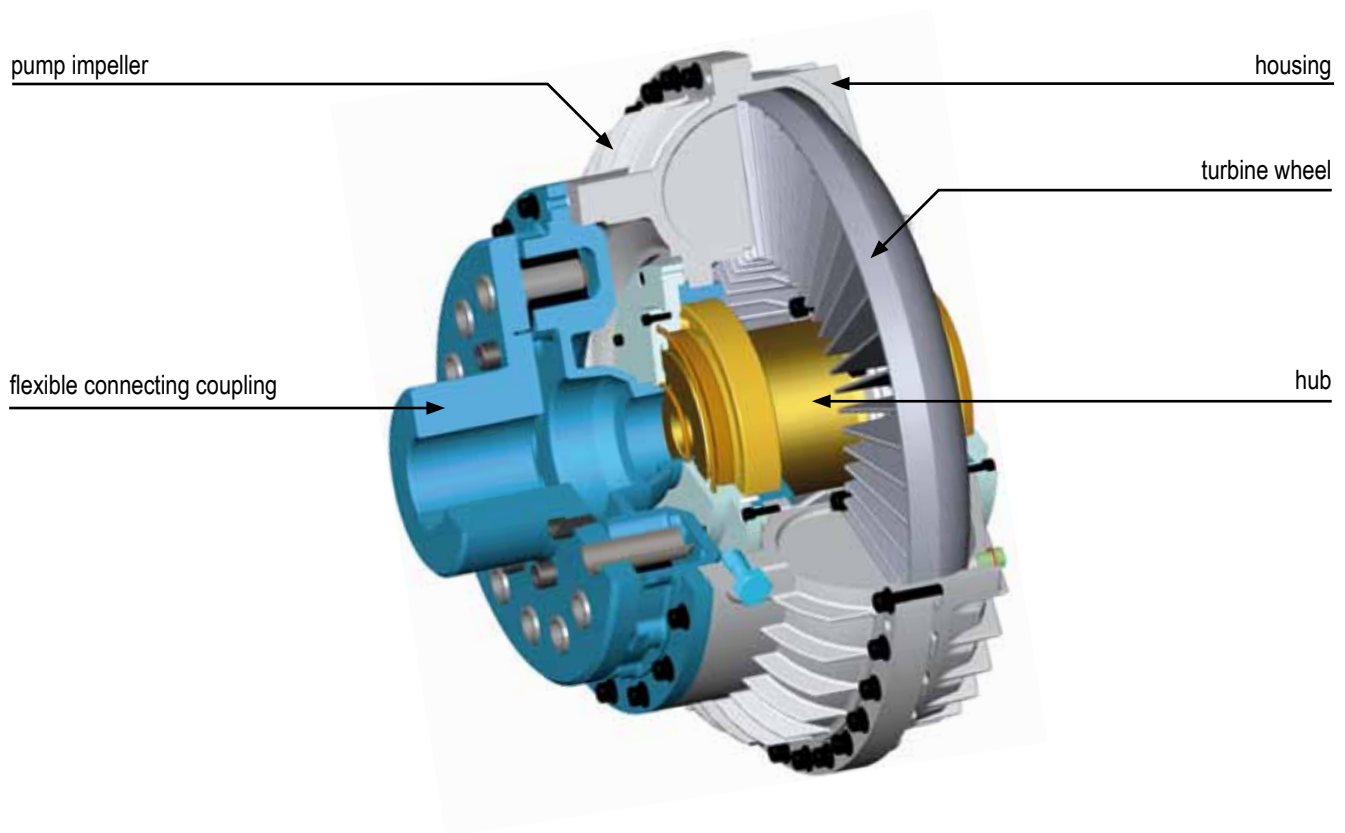

technical features:

Hydrodynamic couplings belong to the group of hydrodynamic power transmission devices.

The power transmission is done by mass forces of the operation liquid according to the „Fröttinger Prinzip“. The impeller pump absorbs the mechanical power of the drive and increases the energy of the circulating operating liquid. The turbine wheel takes energy away from the operating liquid and outputs mechanical power. There is not any fixed connection between both wheels. Slight power losses, caused by the for the power transmission necessary slippage, will be transformed to heat.

The permissible ambient temperature range of the hydrodynamic coupling in standard design is between - 25 °C and + 40 °C (other values on request).

hydrodynamic couplings are distinguished by:

- power transmission free of wear
- steady shock free start up in loaded or unloaded state
- slight backlash on the electrical power supply due to fast abating of the start up current and low start up current
- load compensation on multi motor drives
- efficient decoupling of vibration systems
- damping of shocks, vibration and load changes
- protection against thermal overload by the installed fusible plug or by a mechanical or electronical switch off device

type A

- hydrodynamic coupling with delay chamber

type AV

- hydrodynamic coupling with enlarged delay chamber

type AVZ

- hydrodynamic coupling with an enlarged delay chamber and additional chamber

type AD

- hydrodynamic coupling with two hydrodynamic units

type PO, P, PV, PVZ, PD

- hydrodynamic couplings of the type AO, A, AV, AVZ, AD with brake drum according to DIN 15431

type SO, S, SV, SVZ, SD

- hydrodynamic couplings of the type AO, A, AV, AVZ, AD with brake disk according to DIN 15432

type GMK

- hydrodynamic coupling as before mentioned with two allsteel coupling halves

type KO, K, KV, KVZ

- hydrodynamic couplings of the type AO, A, AV, AVZ with pulley

type MEM

- hydrodynamic coupling type (A/P/S)O, (A/P/S), (AV/PV/SV), (AVZ/PVZ/SVZ), (AD/PD/SD) for mounting the coupling to the motor shaft motor hub with threaded coupling connection and output side

type MRM

- hydrodynamic coupling type (A/P/S)O, (A/P/S), (AV/PV/SV), (AVZ/PVZ/SVZ), (AD/PD/SD) for mounting the coupling to the motor shaft, clutch removable radially without moving the drive and driven unit, output-side connection coupling

For more information on the type designation hydrodynamic couplings TK-N is an overview page on our homepage www.kupplungswerk-dresden.de for download available.

main dimensions in mm

- ¹⁾ max. bore diameter
- ²⁾ max. shaft length
- ³⁾ mass without oil filling
- ⁴⁾ standard design
- ⁵⁾ extra mass to the type A, AV, AVZ, AD calculated, for max. bore diameters
- ⁶⁾ mass without pulley

selection of the coupling

The first coupling selection can be done according to the power characteristics given on page 5.

In case of the wish of a selection done by the manufacturer please use the questionnaire on page 23.

possible installation placements

Hydrodynamic couplings can operate in both rotation directions and can be installed like follow described:

mounting on the motor shaft / gearbox shaft

The drive takes place on the outer wheel, which following Advantages:

- the power transmission of the hydrodynamic coupling increased due to the fact optimized circuit
- the hydrodynamic coupling can be thermally stability operate
- the installed temperature monitoring system delivers always clear signals

typical applications:

- accelerating of large masses for example at mills, centrifuges, mixer, blower, wood working machines, sieves, ball mills, rope machinery and tool machinery.
- start up against high break off torques for example mixer, conveyors, breakers, centrifuges and pumps.
- soft start up at tip and adjustment operation on large mobile equipment.
- safe overload protection for example at dredgers, breakers and scoop wheels.

Special designs for vertical installation of the hydrodynamic coupling are available.

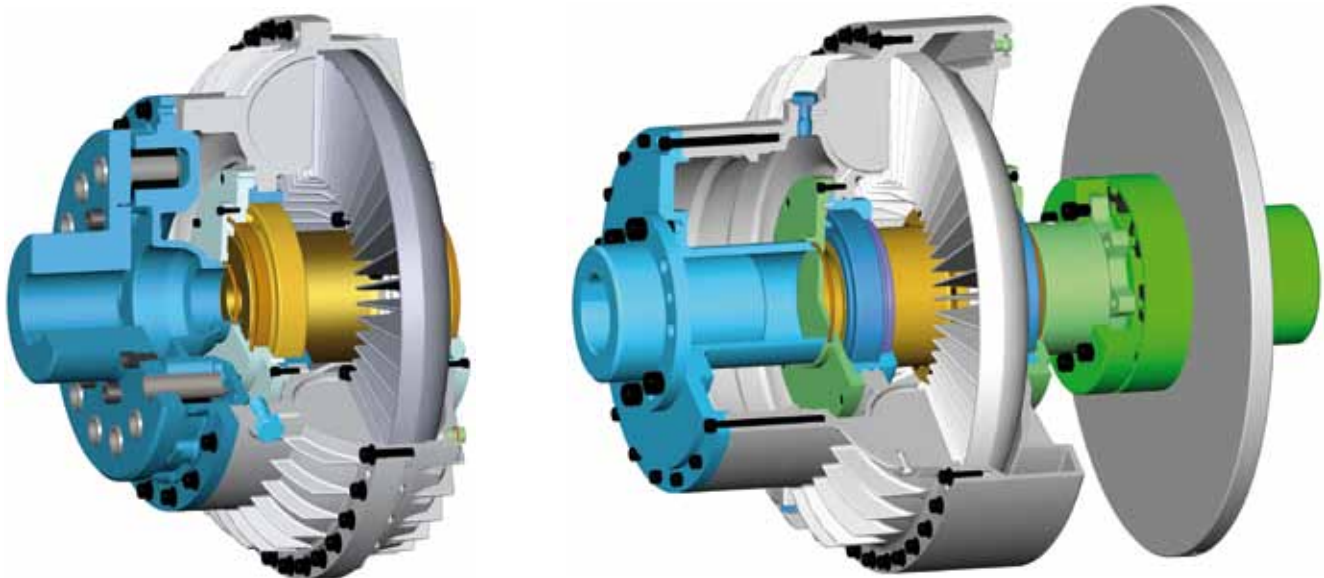

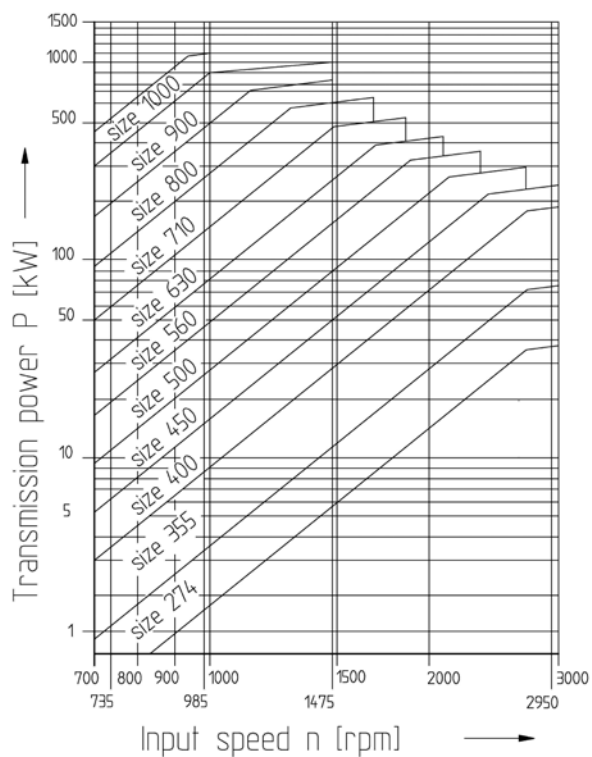

power characteristics for one hydrodynamic unit
(outer drive)

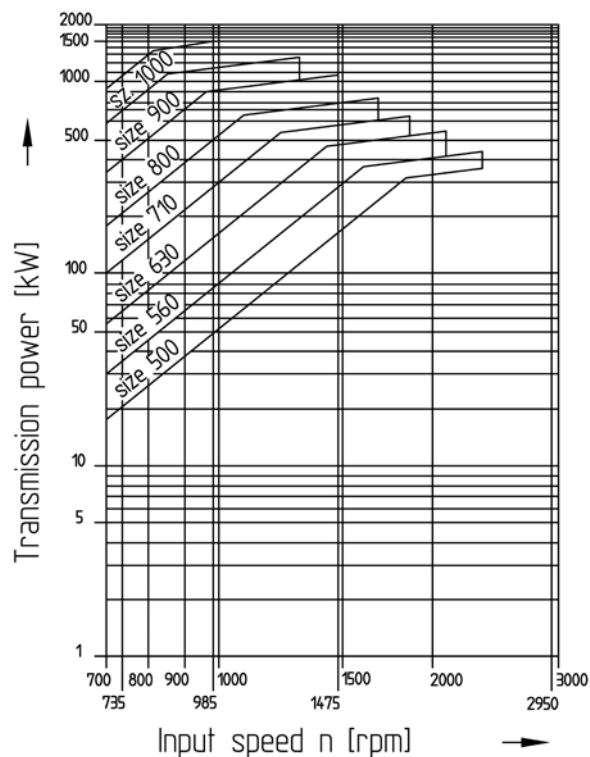

power characteristics for two hydrodynamic units
(outer drive)

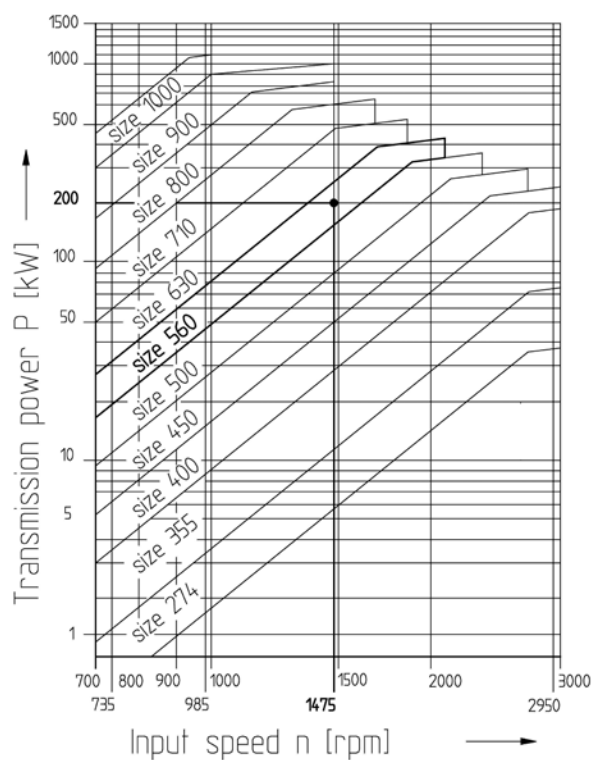

example for selection
(for TK-N, size 560)

- hydrodynamic coupling for an outer drive
- standard design (one hydrodynamic unit)
- drive speed $n = 1475$ rpm
- transmitted power $P_{\text{nominal}} = 200$ kW

type A

- hydrodynamic coupling with delay chamber

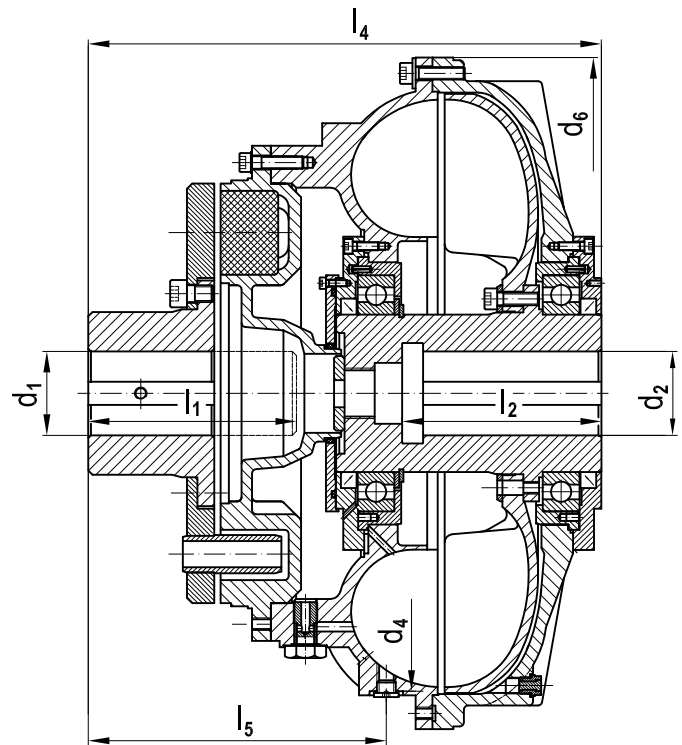
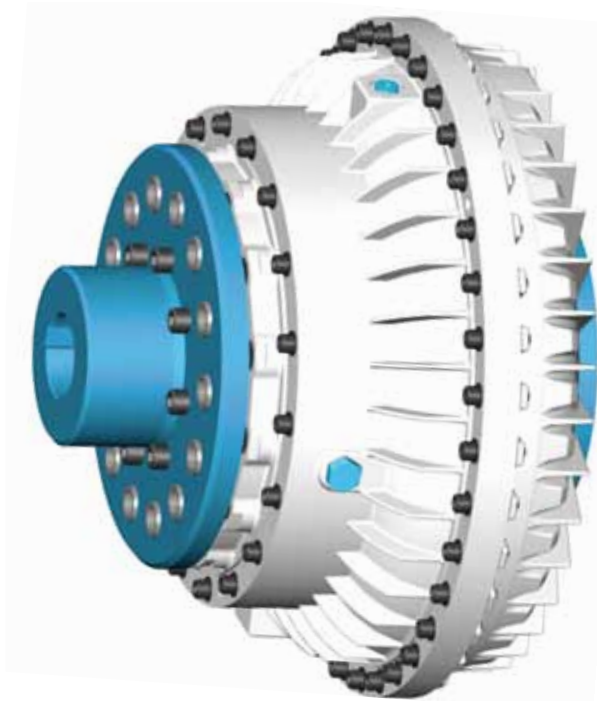

Ordering example: TK-N-A 560 - 65 H7 - 70 H7 x 140 - KWN 29000

Designation of a hydrodynamic coupling type A, nominal size 560, bore of the flexible connection coupling $d_1 = 65 \text{ H7}$, bore of the hydrodynamic coupling $d_2 = 70 \text{ H7}$ for shaft length $l_2 = 140 \text{ mm}$

Footnotes see page 3

main dimensions / characteristic values										Table 1	
size	$d_1^{(1)}$	$d_2^{(1)}$	d_4	d_6	$l_1^{(2)}$	$l_2^{(2)}$	$l_4^{(4)}$	l_5	speed	mass ³⁾	
									n_{max} [rpm]	m [kg]	
274	60	50	272	328	140	110	299,5	177,0	3 600	30	
355	85	55	366	424	125	110	309,0	159,0	3 600	45	
400	85	70	396	470	145	125	365,0	189,0	3 000	65	
450	85	85	456	540	145	165	390,0	196,0	1 740	75	
500	95	95	484	575	165	165	427,0	204,0	1 740	90	
560	110	110	572	640	170	170	489,0	279,0	1 740	175	
630	110	120	646	710	200	170	546,0	336,0	1 740	210	
710	140	125	725	820	230	210	606,0	335,5	1 740	330	
800	140	150	832	930	260	220	651,0	354,0	1 475	450	
900	165	160	890	1 050	300	260	750,0	441,0	1 475	620	
1 000	165	160	1 000	1 118	200	280	676,5	292,5	1 200	750	

type AV

- hydrodynamic coupling with enlarged delay chamber

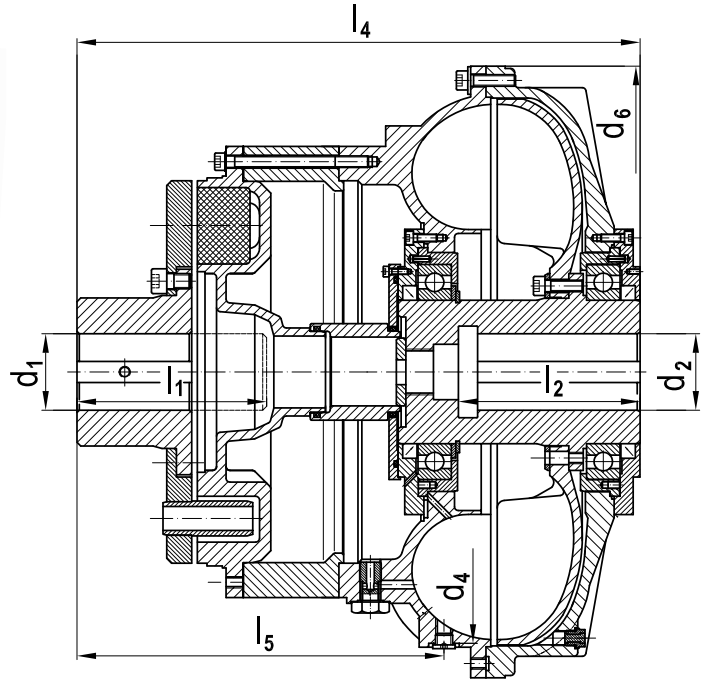
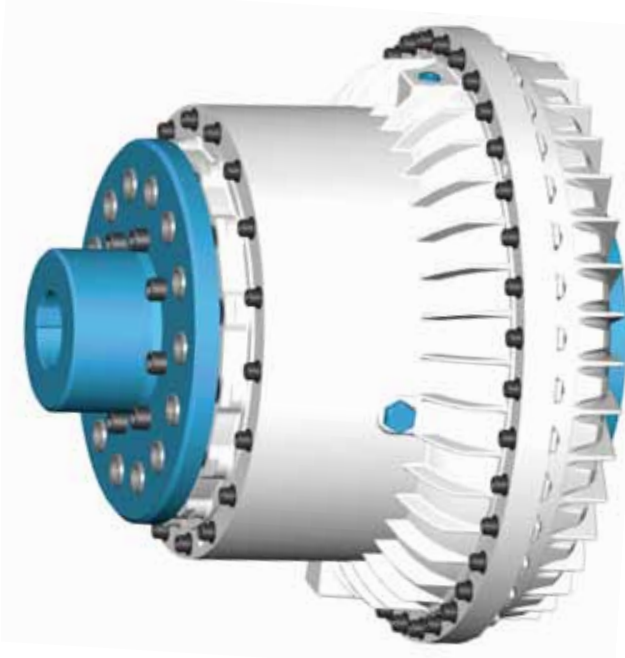

Ordering example: TK-N-AV 560 - 65 H7 - 70 H7 x 140 - KWN 29000

Designation of a hydrodynamic coupling type AV, nominal size 560,
 bore of the flexible connection coupling $d_1 = 65$ H7,
 bore of the hydrodynamic coupling $d_2 = 70$ H7 for shaft length $l_2 = 140$ mm

Footnotes see page 3

Table 2

main dimensions / characteristic values

size	$d_1^{1)}$	$d_2^{1)}$	d_4	d_6	$l_1^{2)}$	$l_2^{2)}$	$l_4^{4)}$	l_5	speed	mass ³⁾
									n_{max} [rpm]	m [kg]
274	60	50	272	328	140	110	339,5	217,0	3 600	32,0
355	85	55	366	424	125	110	386,5	236,5	3 600	51,4
400	85	70	396	470	145	125	479,5	303,5	3 000	75,2
450	85	85	456	540	145	165	504,5	310,5	1 740	85,2
500	95	95	484	575	165	165	541,5	318,5	1 740	100,2
560	110	110	572	640	170	170	589,0	379,0	1 740	188,8
630	110	120	646	710	200	170	646,0	436,0	1 740	223,8
710	140	125	725	820	230	210	731,0	460,5	1 740	356,6
800	140	150	832	930	260	220	776,0	479,0	1 475	476,6
900	165	160	890	1 050	300	260	900,0	591,0	1 475	680,0
1 000	165	160	1 000	1 118	200	280	845,5	461,5	1 200	830,0

type AVZ

- hydrodynamic coupling with an enlarged delay chamber and additional chamber

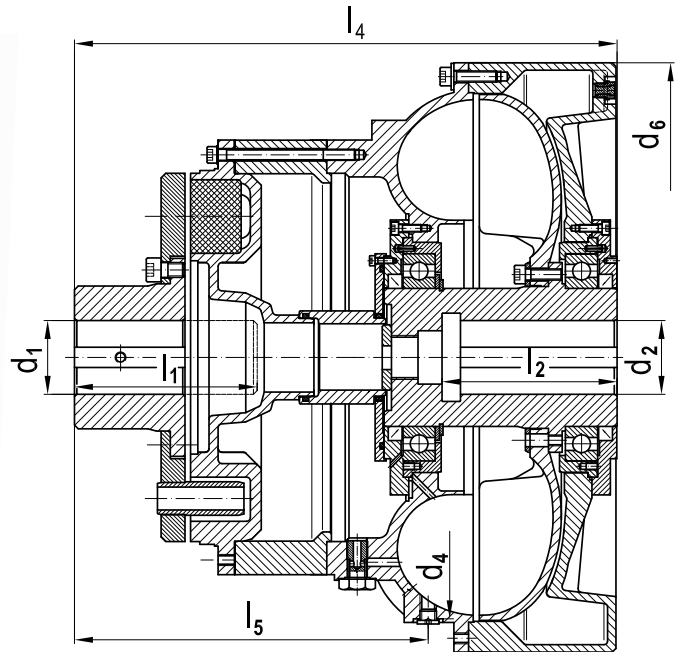
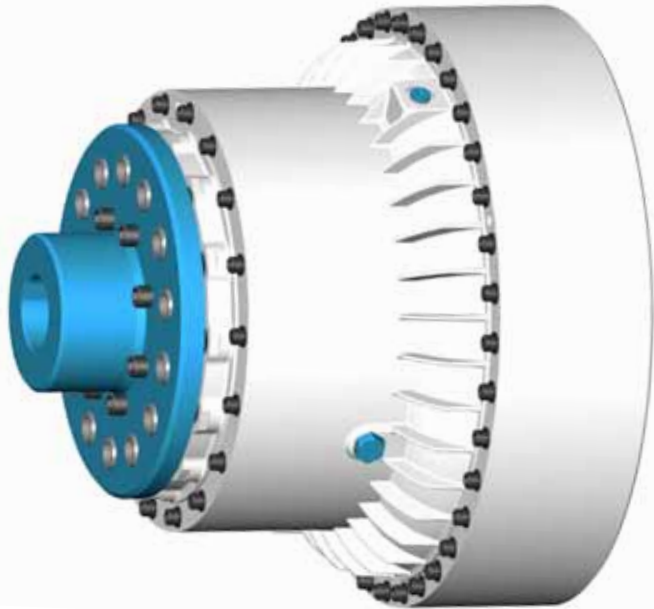

Ordering example: TK-N-AVZ 560 - 65 H7 - 70 H7 x 140 - KWN 29000

Designation of a hydrodynamic coupling type AVZ, nominal size 560,
 bore of the flexible connection coupling $d_1 = 65$ H7,
 bore of the hydrodynamic coupling $d_2 = 70$ H7 for shaft length $l_2 = 140$ mm

Footnotes see page 3

main dimensions / characteristic values									Table 3	
size	$d_1^{1)}$	$d_2^{1)}$	d_4	d_6	$l_1^{2)}$	$l_2^{2)}$	$l_4^{4)}$	l_5	speed	mass ³⁾
									n_{max} [rpm]	m [kg]
400	85	70	396	470	145	125	479,5	303,5	3 000	75
450	85	85	456	540	145	165	504,5	310,5	1 740	85
500	95	95	484	575	165	165	541,5	318,5	1 740	100
560	110	110	572	640	170	170	589,0	379,0	1 740	189
630	110	120	646	710	200	170	646,0	436,0	1 740	224
710	140	125	725	820	230	210	731,0	460,5	1 740	357
800	140	150	832	930	260	220	776,0	479,0	1 475	477
900	165	160	890	1 050	300	260	900,0	591,0	1 475	680
1 000	165	160	1 000	1 118	200	280	845,5	461,5	1 200	830

type AD

- hydrodynamic coupling with two hydrodynamic units

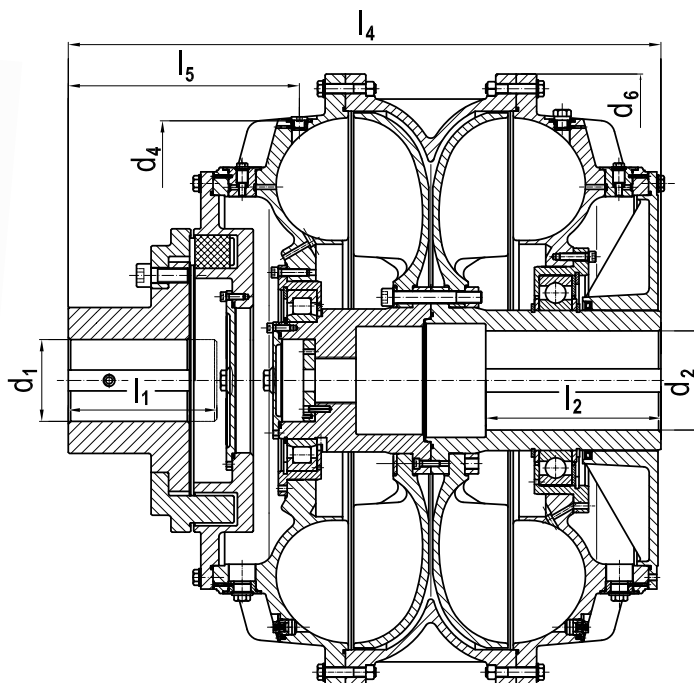

Ordering example: TK-N-AD 560 - 65 H7 - 70 H7 x 140 - KWN 29000

Designation of a hydrodynamic coupling type AD, nominal size 560,
bore of the flexible connection coupling $d_1 = 65$ H7,
bore of the hydrodynamic coupling $d_2 = 70$ H7 for shaft length $l_2 = 140$ mm

Footnotes see page 3

Table 4		main dimensions / characteristic values								
size	$d_1^{(1)}$	$d_2^{(1)}$	d_4	d_6	$l_1^{(2)}$	$l_2^{(2)}$	$l_4^{(4)}$	l_5	speed	mass ⁽³⁾
									n_{\max} [rpm]	m [kg]
500	95	95	484	575	165	170	550	204,0	1 740	125
560	110	110	572	640	170	210	570	279,0	1 740	245
630	110	120	646	710	200	210	630	336,0	1 740	300
710	140	125	725	820	230	250	650	335,5	1 740	460
800	140	150	832	930	260	250	715	354,0	1 475	630
900	165	160	890	1 050	300	300	900	441,0	1 475	870
1 000	165	160	1 000	1 118	200	300	980	292,5	1 200	1 050

type PO, P, PV, PVZ, PD

- hydrodynamic couplings of the type AO, A, AV, AVZ, AD with brake drum according to DIN 15431

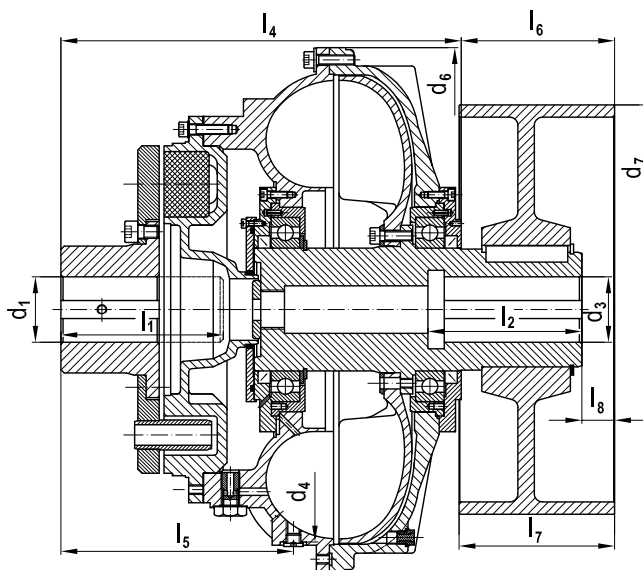
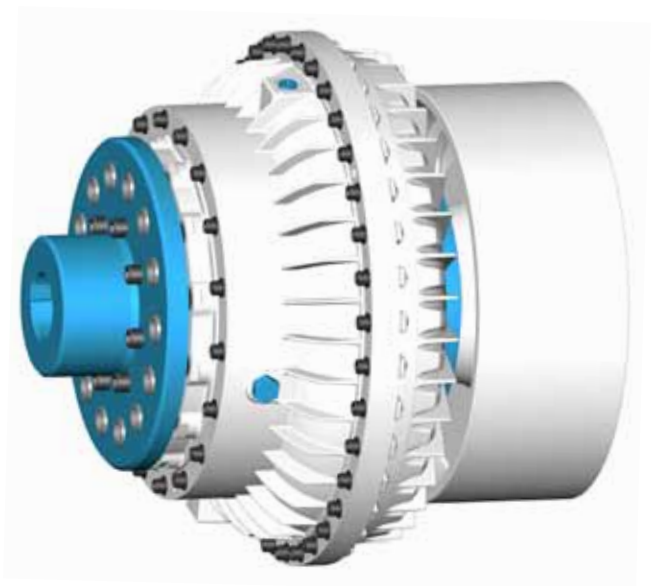

Ordering example: TK-N-P 560 - 65 H7 - 70 H7 x 140 - 500 x 190 - KWN 29000

Designation of a hydrodynamic coupling type P, nominal size 560,
 bore of the flexible connection coupling $d_1 = 65 \text{ H7}$,
 bore of the hydrodynamic coupling $d_3 = 70 \text{ H7}$ for shaft length $l_2 = 140 \text{ mm}$, brake drum $500 \times 190 \text{ mm}$

Footnotes see page 3

main dimensions / characteristic values							Table 5
size	brake drum d_7	$d_3^{1)}$	l_6	l_7	l_8	speed n_{\max} [rpm]	mass ⁵⁾ m [kg]
274	200	40	83	75	0	3 600	39
	250	40	103	95	20	3 600	47
	315	40	126	118	43	3 600	59
355	200	50	83	75	0	3 600	54
	250	50	103	95	20	3 600	62
	315	50	126	118	43	3 600	74
400	250	70	106	95	23	3 000	82
	315	70	152	118	46	3 000	94
	400	70	216	150	78	3 000	117
450	315	70	152	118	46	1 740	104
	400	70	216	150	78	1 740	127
	500	70	256	190	118	1 740	167
500	315	70	152	118	46	1 740	119
	400	70	216	150	78	1 740	142
	500	70	256	190	118	1 740	182
560	400	100	207	150	80	1 740	227
	500	100	287	190	120	1 740	267
	630	100	333	236	166	1 740	349
630	500	110	234	190	70	1 740	302
	630	110	276	236	101	1 740	384
	710	110	305	265	130	1 740	472
710	500	125	243	190	70	1 740	422
	630	125	265	236	80	1 740	504
	710	125	318	265	84	1 740	592
800	500	125	192	190	10	1 475	542
	630	125	237	236	56	1 475	624
	710	125	315	265	75	1 475	712
900	500	140	192	190	11	1 475	712
	630	140	237	236	57	1 475	794
	710	140	315	265	75	1 475	882
1 000	710	160	315	265	75	1 200	1 012

type SO, S, SV, SVZ, SD

- hydrodynamic couplings of the type AO, A, AV, AVZ, AD with brake disk according to DIN 15432

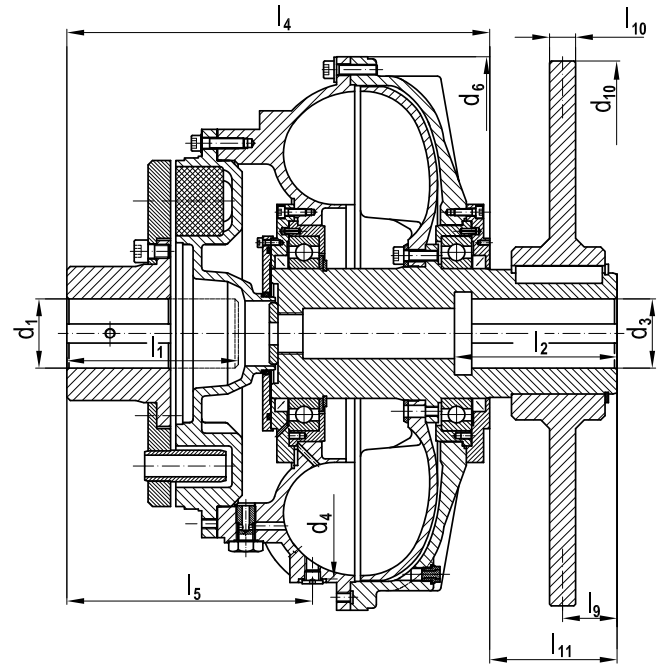
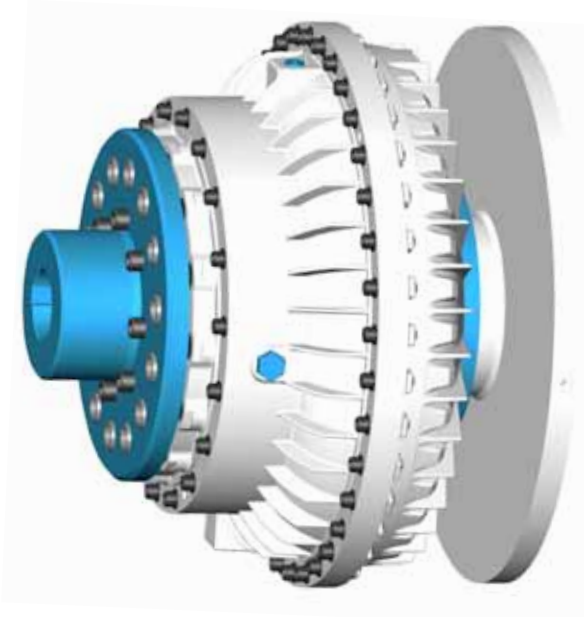
Ordering example: TK-N-S 560 - 65 H7 - 70 H7 x 140 - 500 x 30 - KWN 29000

Designation of a hydrodynamic coupling type S, nominal size 560,
 bore of the flexible connection coupling $d_1 = 65$ H7,
 bore of the hydrodynamic coupling $d_2 = 70$ H7 for shaft length $l_2 = 140$ mm, brake disk 500 x 30 mm

Footnotes see page 3

Main dimensions according to type A, AV, AO, AD. Additional the following dimensions and masses are valid:

Table 6		main dimensions / characteristic values					
size	brake disk d_{10}	$d_3^{1)}$	l_9	l_{10}	l_{11}	speed n_{max} [rpm]	mass ⁵⁾ m [kg]
274	200	40	18	15	75	3 600	36
	355	40	19	15	75	3 600	46
	400	40	30	30	75	3 600	51
355	200	50	18	15	75	3 600	52
	355	50	19	15	75	3 600	62
	400	50	30	30	75	3 600	67
400	355	70	19	15	100	3 000	85
	400	70	30	30	100	3 000	90
	450	70	30	30	100	3 000	95
450	400	70	30	30	100	1 740	102
	450	70	30	30	100	1 740	107
	500	70	30	30	100	1 740	113
500	400	70	30	30	125	1 740	117
	450	70	30	30	125	1 740	122
	500	70	30	30	125	1 740	128
560	450	100	30	30	125	1 740	207
	500	100	30	30	125	1 740	219
	630	100	35	30	125	1 740	238
630	500	110	30	30	125	1 740	254
	630	110	30	30	125	1 740	401
	710	110	35	30	125	1 740	553
710	500	125	30	30	170	1 740	386
	630	125	30	30	170	1 740	404
	710	125	35	30	170	1 740	444
800	500	125	30	30	170	1 475	512
	630	125	30	30	170	1 475	530
	710	125	35	30	170	1 475	569
900	630	140	30	30	170	1 475	706
	710	140	30	30	170	1 475	749
	800	140	35	30	170	1 475	770
1 000	800	160	35	30	170	1 200	900

type GMK

- hydrodynamic coupling as before mentioned with two allsteel coupling halves

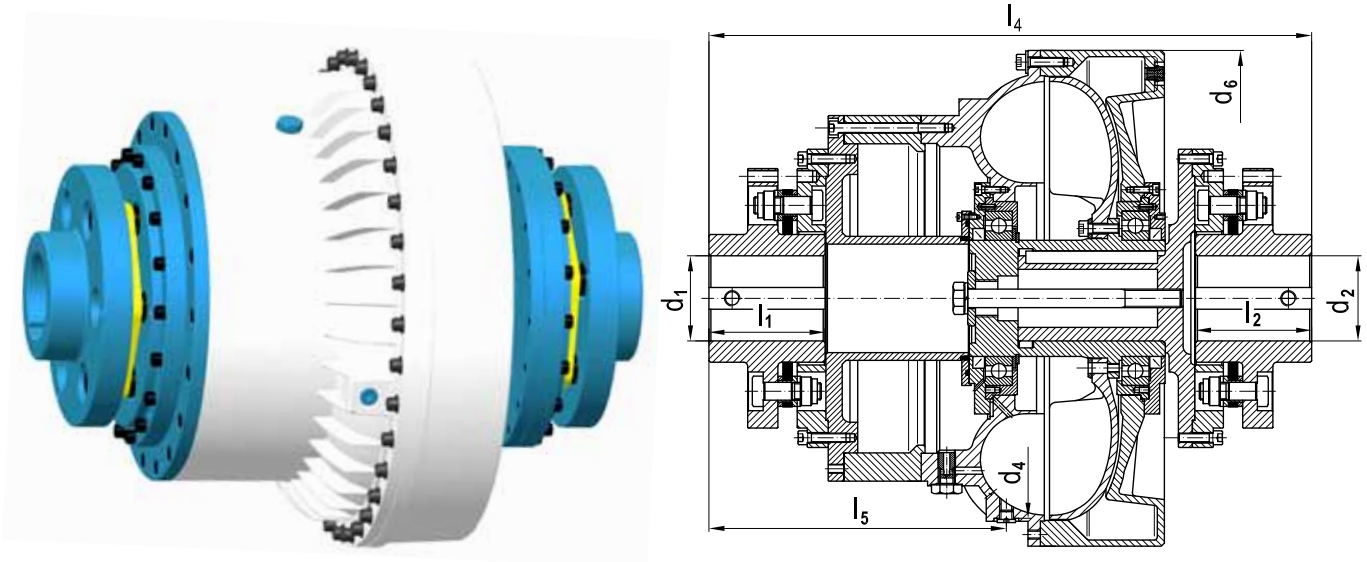

Ordering example: TK-N-AVZ-GMK 560 - 65 H7 x 140 - 70 H7 x 140 - KWN 29000

Designation of a hydrodynamic coupling type AVZ-GMK of nominal size 560, bore of the engine side GMK coupling half $d_1 = 65$ H7 with shaft length $l_2 = 140$ mm, bore the gear side GMK-half coupling $d_2 = 70$ H7 with shaft length $l_2 = 140$ mm

Footnotes see page 3

main dimensions / characteristic values											Table 7		
size	$d_1^{(1)}$	$d_2^{(1)}$	d_4	d_6	$l_1^{(2)}$	$l_2^{(2)}$	l_4	l_5			speed n_{max} [rpm]	mass ³⁾ m [kg]	
									TK-N-A-GMK	TK-N-AV-GMK TK-N-AVZ-GMK		TK-N-A-GMK	AV/AVZ-GMK
400	80	80	396	470	170	170	718,5	280	833	394,5	3 000	125	135
450	80	80	456	540	170	170	743,5	287	858	401,5	1 740	135	145
500	80	80	484	575	170	170	780,5	295	895	409,5	1 740	147	157
560	105	105	572	640	210	210	795,5	318	895,5	418,0	1 740	312	326
630	125	125	646	710	210	210	843,5	345	943,5	445,0	1 740	420	433
710	135	135	725	820	250	250	978,5	369	1 103,5	494,0	1 740	565	592
800	135	135	832	930	250	250	1 023,5	387,5	1 148,5	512,5	1 475	685	712
900	160	160	890	1 050	300	300	1 244,5	509	1 394,5	659,0	1 475	905	965
1 000	190	190	1 000	1 118	350	350	1 385,5	517	1 554,5	686,0	1 200	1 080	1 160

type KO, K, KV, KVZ

- hydrodynamic couplings of the type AO, A, AV, AVZ with pulley

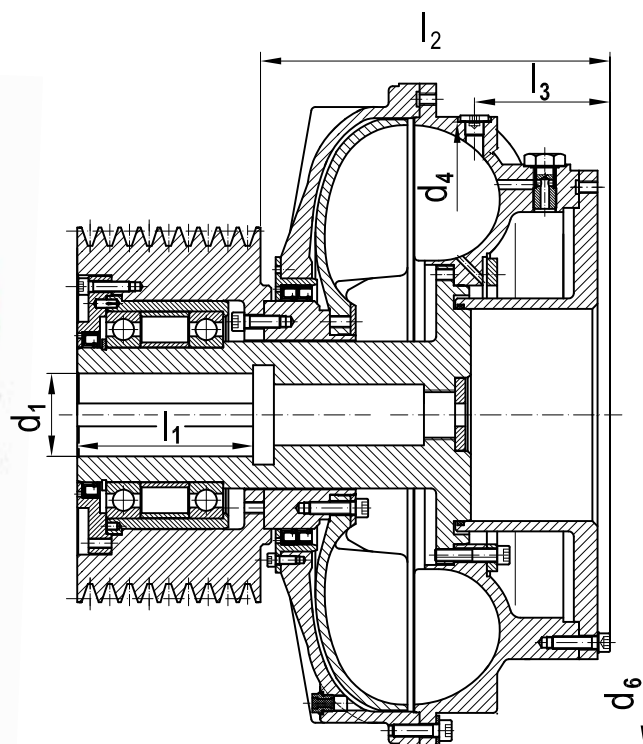
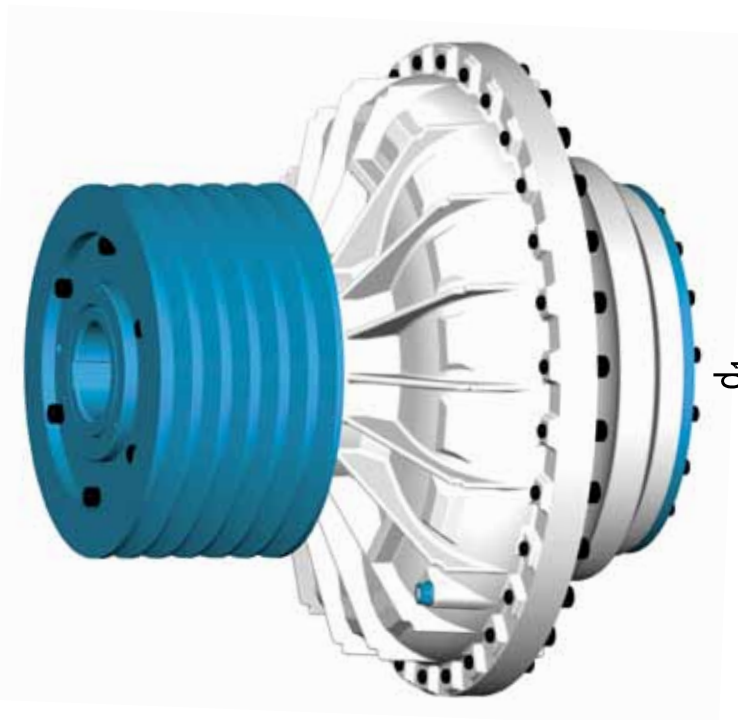

Ordering example: TK-N-K 560 - 70 H7 x 140 KRS400 - 8 x SPC - KWN 29000

Designation of a hydrodynamic coupling type K, nominal size 560, bore of the hydrodynamic coupling $d_1 = 70$ H7 for shaft length $l_1 = 140$ mm, pulley diameter $d_w = 400$ - 8 grooves with profile SPC

Footnotes see page 3

Table 8		main dimensions / characteristic values								
size	d_4	d_6	l_2	l_3	l_2	l_3	l_2	l_3	mass ⁶⁾ m [kg]	mass ⁶⁾ m [kg]
			TK-N-K		TK-N-KV		TK-N-KVZ		TK-N-K	TK-N-KV / TK-N-KVZ
274	272	328	152	25,0	192,0	65,0	192,0	65,0	30	32
355	366	424	220	65,0	297,5	142,5	297,5	142,5	45	51
400	396	470	276	95,0	390,5	209,5	390,5	209,5	65	75
450	456	540	301	102,0	415,5	216,5	415,5	216,5	75	85
500	484	575	338	110,0	452,5	224,5	452,5	224,5	90	100
560	572	640	316	123,0	416,0	223,0	416,0	223,0	175	189
630	646	710	353	160,0	453,0	260,0	453,0	260,0	210	224
710	725	820	415	142,5	540,0	267,5	540,0	267,5	330	357
800	832	930	460	164,0	585,0	289,0	585,0	289,0	450	477
900	890	1050	523	218,0	673,0	368,0	673,0	368,0	620	680
1 000	1 000	1 118	538	178,0	707,0	347,0	707,0	347,0	750	830

type MEM

- hydrodynamic couplings of the type (A/P/S)O, (A/P/S), (AV/PV/SV), (AVZ/PVZ/SVZ), (AD/PD/SD) for mounting the coupling to the motor shaft motor hub with threaded coupling connection and output side

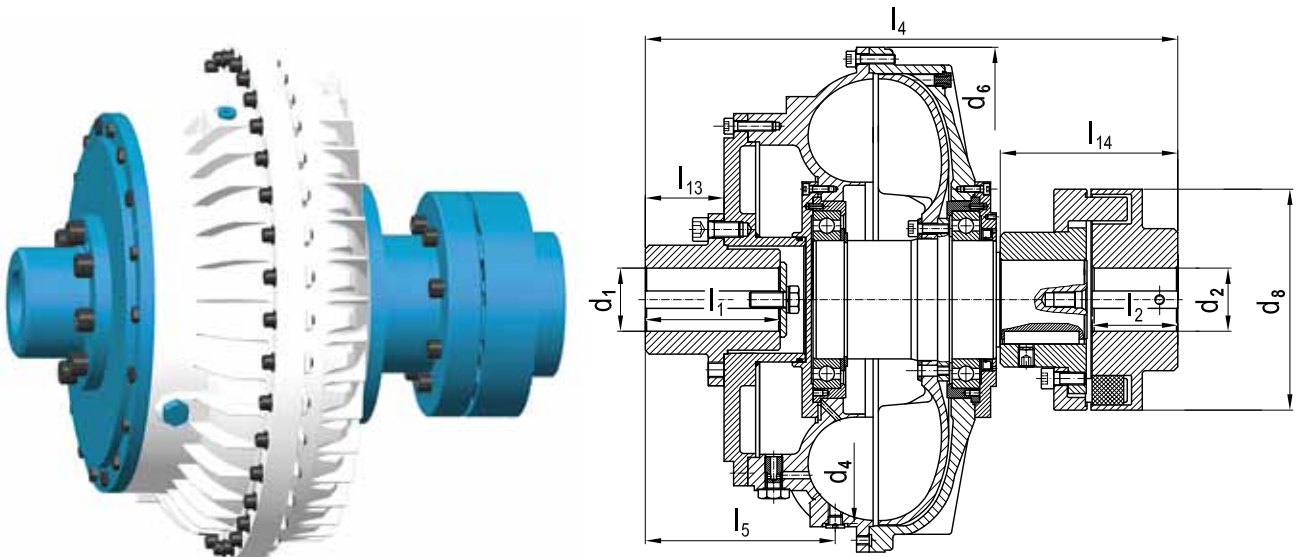

Ordering example: TK-N-A-MEM 560 - 65 H7 - 70 H7 x 140 - KWN 29000

Designation of a hydrodynamic coupling type A-MEM of nominal size 560, bore of the elastic connection coupling $d_1 = 65 H7$, bore the hydrodynamic coupling $d_2 = 70 H7$ for shaft length $l_2 = 140$ mm

Footnotes see page 3

main dimensions / characteristic values																Table 9	
size	$d_1^{1)}$	$d_2^{1)}$	d_4	d_6	d_8	l_1	l_2	TK-N-A		TK-N-AV		TK-N-AVZ		l_{13}	l_{14}	speed n_{max} [rpm]	mass ⁵⁾ m [kg]
								l_4	l_5	l_4	l_5	l_4	l_5				
274	55	60	272	328	140	110	55	345,5	105,0	375,5	145,0	375,5	145,0	80	113	3 600	7
355	90	85	366	424	200	170	80	534	215,0	606,5	292,5	606,5	292,5	145	164	3 600	20
400	90	85	396	470	200	170	80	575	230,0	679,5	344,5	679,5	344,5	130	164	3 000	20
450	90	85	456	540	200	170	80	600	237,0	704,5	351,5	704,5	351,5	130	164	1 740	20
500	90	90	484	575	225	170	90	637	225,0	731,5	339,5	731,5	339,5	110	184	1 740	27
560	95	100	572	640	250	170	100	654	235,0	734,0	335,0	734,0	335,0	100	204	1 740	37
630	125	110	646	710	280	250	110	776	337,0	851,0	437,0	851,0	437,0	165	224	1 740	48
710	130	140	725	820	350	250	140	881	321,5	981,0	446,5	981,0	446,5	170	284	1 740	92
800	130	150	832	930	400	250	160	986	360,0	1 091	485,0	1 091	485,0	190	324	1 475	130
900	140	160	890	1 050	440	250	180	1 064	383,0	1 184	533,0	1 184	533,0	150	367	1 475	167
1 000	160	190	1 000	1 118	520	300	210	1 179	363,0	1 313	532,0	1 313	532,0	175	427	1 200	275

type MRM

- hydrodynamic couplings of the type (A/P/S)O, (A/P/S), (AV/PV/SV), (AVZ/PVZ/SVZ), (AD/PD/SD) for mounting the coupling to the motor shaft, coupling removable radially without moving the drive and driven unit, output-side connection coupling

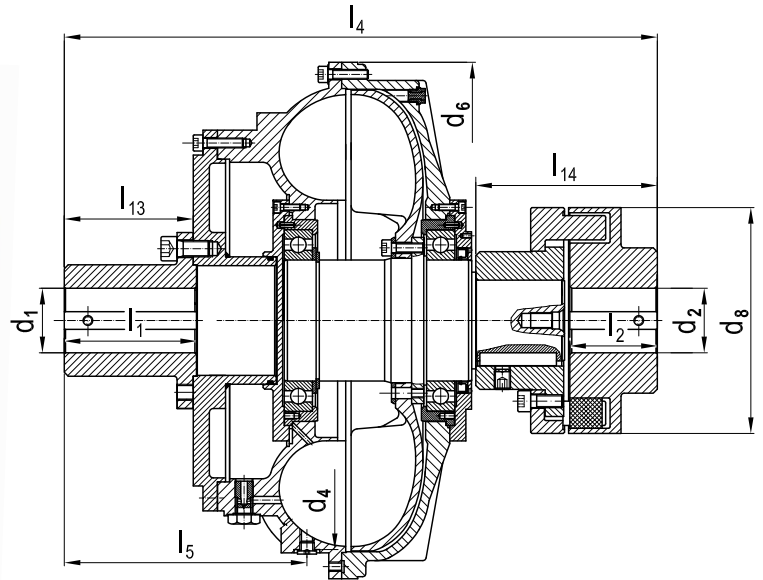
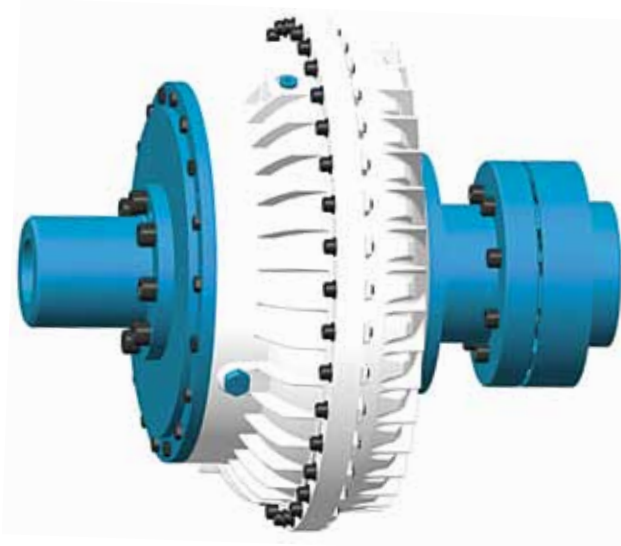

Ordering example: TK-N-A-MRM 560 - 65 H7 - 70 H7 x 140 - KWN 29000

Designation of a hydrodynamic coupling type A-MRM of nominal size 560, bore of the elastic connection coupling $d_1 = 65$ H7, bore the hydrodynamic coupling $d_2 = 70$ H7 for shaft length $l_2 = 140$ mm

Footnotes see page 3

Table 10		main dimensions / characteristic values															
size	$d_1^{(1)}$	$d_2^{(1)}$	d_4	d_6	d_8	$l_1^{(2)}$	$l_2^{(2)}$	l_4	l_5	l_4	l_5	l_4	l_5	l_{13}	l_{14}	speed n_{max} [rpm]	mass ⁵⁾ m [kg]
								TK-N-A		TK-N-AV		TK-N-AVZ					
274	55	60	272	328	140	110	55	373,5	133,0	413,5	173,0	413,5	173,0	108	113	3 600	7
355	90	85	366	424	200	170	80	557,0	238,0	634,5	315,5	634,5	315,5	168	164	3 600	20
400	90	85	396	470	200	170	80	613,0	268,0	727,5	382,5	727,5	382,5	168	164	3 000	20
450	90	85	456	540	200	170	80	638,0	275,0	752,5	389,5	752,5	389,5	168	164	1 740	20
500	90	90	484	575	225	170	90	695,0	283,0	809,5	397,5	809,5	397,5	168	184	1 740	27
560	95	100	572	640	250	170	100	762,0	343,0	862,0	443,0	862,0	443,0	208	204	1 740	37
630	125	110	646	710	280	250	110	859,0	420,0	959,0	520,0	959,0	520,0	248	224	1 740	48
710	130	140	725	820	350	250	140	959,0	399,5	1 084,0	524,5	1 084,0	524,5	248	284	1 740	92
800	130	150	832	930	400	250	160	1 044,0	418,0	1 169,0	543,0	1 169,0	543,0	248	324	1 475	130
900	140	160	890	1 050	440	250	180	1 160,0	479,0	1 310,0	629,0	1 310,0	629,0	246	367	1 475	167
1 000	160	190	1 000	1 118	520	300	210	1 300,0	484,0	1 469,0	653,0	1 469,0	653,0	296	427	1 200	275

type AO, A, AV, AVZ, AD

- flexible claw-coupling ELKU-N according to KWN 22013 (nominal sizes 274 - 500) as well as flexible package coupling according to KWN 22016 (nominal sizes 560 - 1 000)
- standard fusible plug (145 °C), assembled in the coupling
- exchangeable standard nozzle set beginning with nominal size 560, assembled in the coupling
- fixing elements (hexagon screw, disk and spring washer), loosely supplied

type KO, K, KV, KVZ

- pulleypoint and -dimension according to customers request, mounted on the coupling
- standard fusible plug (145 °C), assembled in the coupling
- exchangeable standard nozzle set beginning with nominal size 560, assembled in the coupling
- fixing elements (hexagon screw, disk and spring washer), loosely supplied

type PO, P, PV, PVZ, PD sowie S, SV, SVZ, SD

- flexible claw coupling ELKU-N according to KWN 22013 (nominal sizes 274 - 500) as well as flexible package coupling according to KWN 22016 (nominal sizes 560 - 1 000)
- brake drum or brake disk, in dimension and type according to customers request, possibly with connection elements, mounted on the coupling
- standard fusible plug (145 °C), assembled in the coupling
- exchangeable standard nozzle set beginning with nominal size 560, assembled in the coupling
- fixing elements (hexagon screw, disk and spring washer), loosely supplied

For a professional coupling selection and sizing another connection coupling available to the user our engineering staff.

recommended materials for brake drum and brake disks

Table 11

material	remark	recommended utilization case
EN-GJL-250 DIN EN 1561	high frictional coefficient low permissible speed low wear	holding and service brakes
EN-GJS-400-15U DIN EN 1563 EN-GJS-700-2U DIN EN 1563	low frictional coefficient very good wearing properties	service brake
GE 300 DIN EN 10293 hard chromium plate	minimum of 300 Brinell hardness decrease in frictional coefficient at high temperatures very low wear average frictional coefficient	service brake
GE 300 DIN EN 10293 hardened	minimum of 300 Brinell hardness high frictional coefficient over a wide range of temperature good temperature stability of frictional coefficient wear	holding brakes and service brakes at high temperatures
GE 300 DIN EN 10293 untreated	average frictional coefficient low surface solidity leads to pickup and thus to a high level of wear	holding brake

balance

The couplings will be dynamically balanced.

Standard balancing quality is Q 6,3 at 1500 rpm according to VDI 2060 in two planes.

Other balancing qualities possible. Please contact us.

operation liquid

The operation liquid has to have the following characteristic values:

operation liquid characteristics	Table 12
kinematic viscosity at 40 °C	27-60 cSt
density at 20 °C	0,85 - 0,91 g/cm ³
flashing point	170 °C
solidification point	-25 °C at outside operation
water content	≤ 0,1 %
tendency towards foaming	low

recommended oils

Followings sorts of oil are useable:

oil characteristic	Table 13
Addinol	H 46 R/TL 36
BP Oil	HL 32 / HL 22
Deutsche Shell	Shell Tellus 32
Wintershall AG	Wiolan HF 32
Mobil Oil AG	Mobilfluid 120
Deutsche Total GmbH	Total Azolla 32
Esso AG	Torque Fluid N 45
DEA Mineralöl AG	Astron HLP 32

Hydrodynamic couplings with special working conditions or by using of different sorts of oil, please contact us.

quantities of oil

The oil quantity depends on the type of coupling and the transmitted drive power. Further information concerning oil fill level are available in coupling installation instruction. System related adjustments have to align on site.

operating medium water

Hydrodynamic couplings can also with a water glycol mixture can be operated. The advantages of this equipment are the cost-effective procurement and Presence of increased environmental regulations. Construction of this Input use an additional encapsulation of the bearings.

The rolling bearings can no longer be on the made oil fill, but is a lifetime grease ensured. This results in modified insertion lengths the TK-N Series.

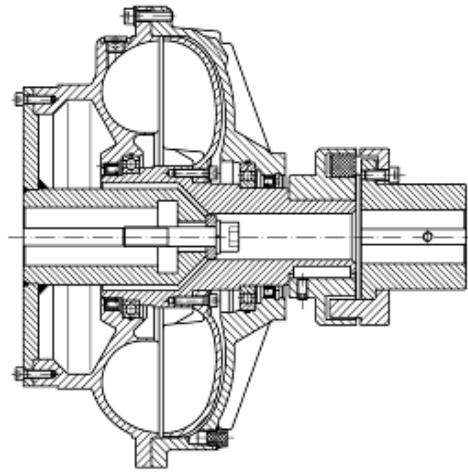
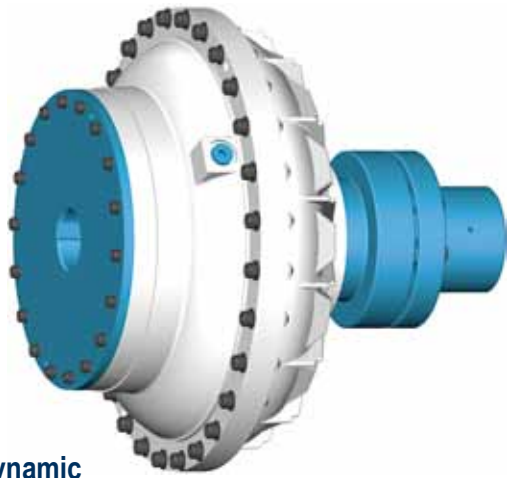

**hydrodynamic
coupling TK-N-AO-MEM ___ s**

coupling without delay chamber, engine assembly, retracted motor hub with flexible connecting coupling vibrations in parallel drives

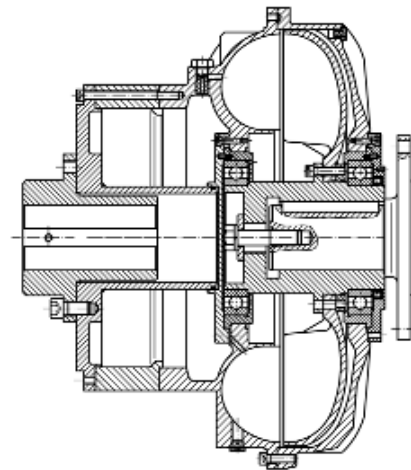
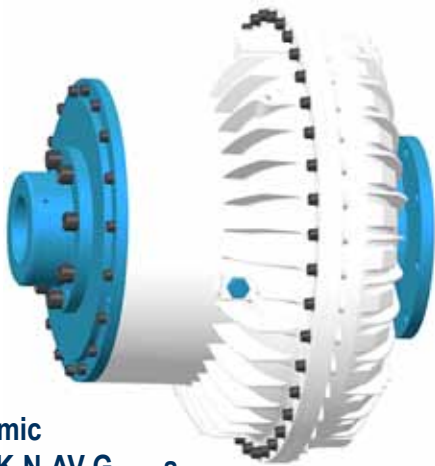

**hydrodynamic
coupling TK-N-AV-G ___ s**

coupling with an extended delay chamber and companion flange

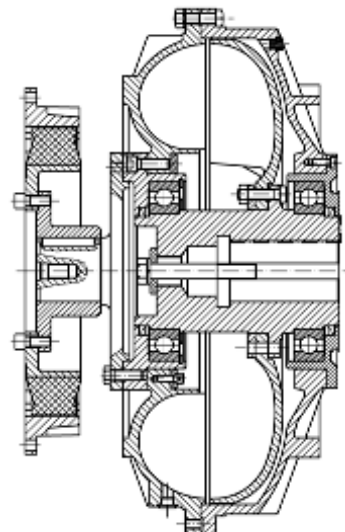

**hydrodynamic
coupling TK-N-AO-D ___ s**

coupling without delay chamber with highly flexible connected coupling for diesel engine drive

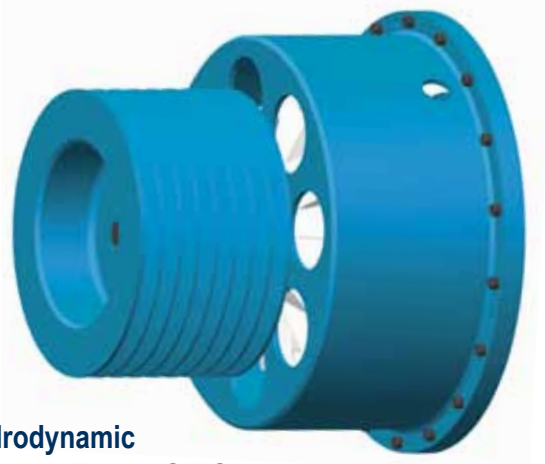

**hydrodynamic
coupling TK-N-AO DG__s**

coupling without delay chamber for diesel engine drive in separate housing

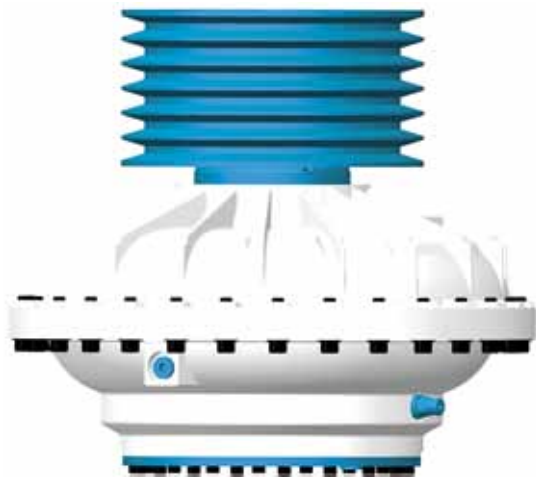
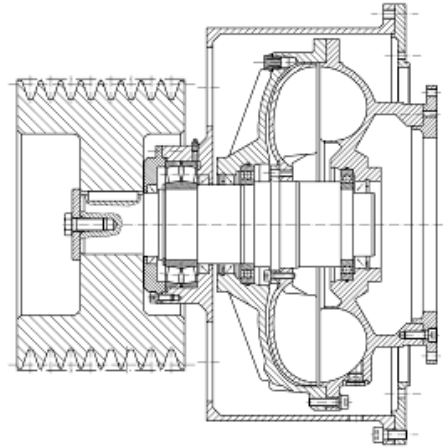

**hydrodynamic
coupling TK-N-K__av**

coupling with delay chamber, pulley, for vertical installation

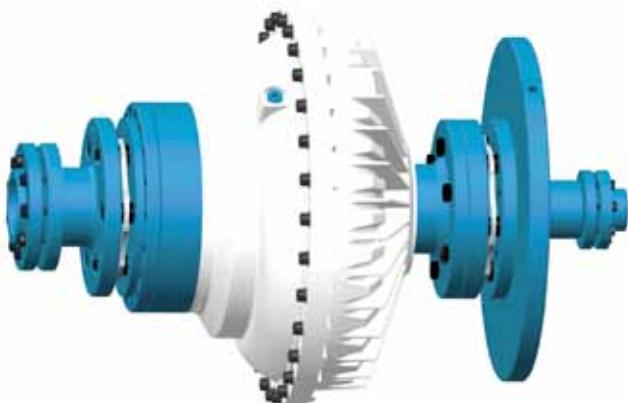
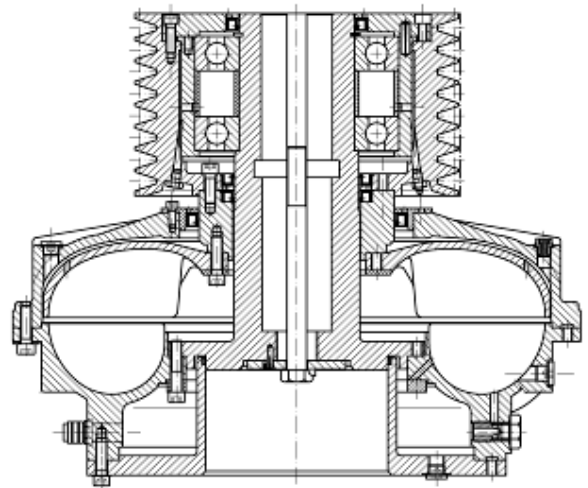

**hydrodynamic
coupling TK-N-SV-GMK__s**

coupling with an extended delay chamber and brake disk, radially removable between allsteel couplings, special design with external clamping sets

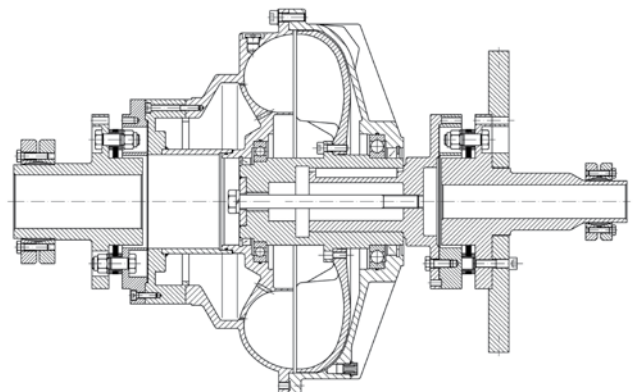

insert bushings

By using of insert bushing couplings of the same size and type can be adapted to different shaft diameter and shaft length. The insert bushing can be delivered in pilot- and finished bore for the insert bushings intended types on request.

protection cover

In order to protect staff against unintentional touch of the rotating parts of the hydrodynamic coupling a protection cover is necessary. The design of the cover has to be made in such a way that the cooling of the coupling by an air circulation is guaranteed. Covers in standard or special design are available on request.

replacement for the fusible plug

The delivery of replacements for the fusible plug, also for different reaction temperatures, is possible on request.

electronical thermal switch off device

Hydrodynamic couplings are protected against damage due to high operation temperature by a fusible plug.

The electronical thermal switch off device has a lower reaction temperature than a fusible plug and avoids in the case of thermal overload the loss of the operation liquid by delivering a signal. The signal will be picked up touchless from a sensor, transferred to an analysis unit and converted into a signal for switching off the drive system.

nozzle sets

Hydrodynamic couplings beginning with nominal size 560 will be delivered with an exchangeable standard nozzle set. By using of adapted nozzles the start up characteristic of the coupling can be adjusted to the application within a special range. These nozzles are available on request.

oil filling

According to standard hydrodynamic couplings will be delivered without oil filling. The oil filling can be delivered separately in usual package units.

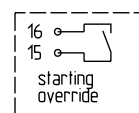
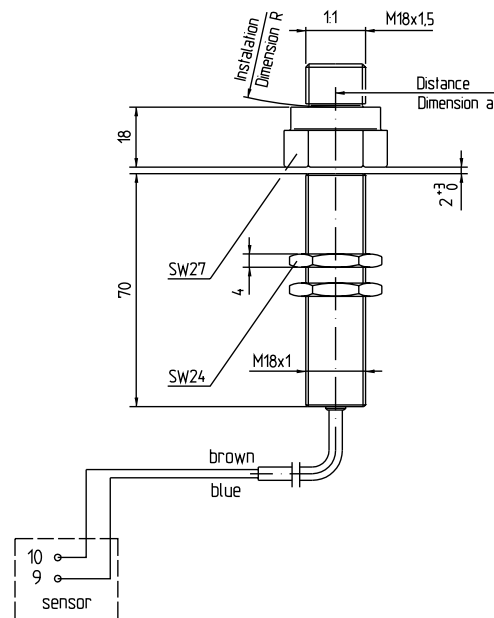
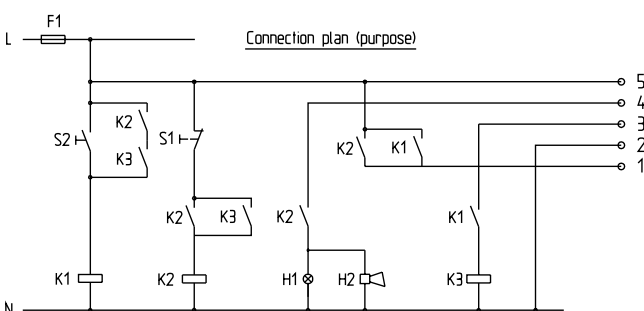
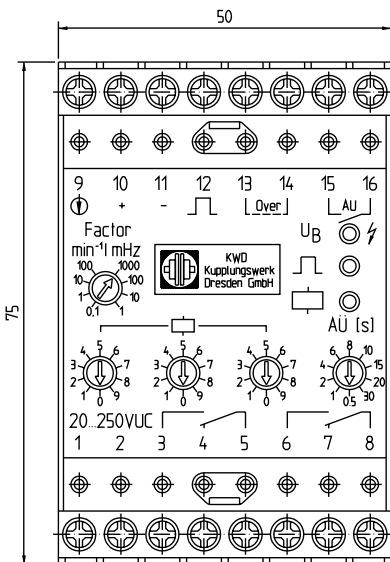

- Connection plan (purpose)**
Description
- L ... phase
 - N ... centre (neutral)
 - F1 ... safety device
 - H1 ... light
 - H2 ... horn
 - K1 ... motor contactor
 - K2 ... relay
 - K3 ... relay
 - S1 ... "OUT" - key
 - S2 ... "in" - key

mechanical thermal switch off device

Hydrodynamic couplings are protected against damage due to high operation temperature by a fusible plug. The mechanical thermal switch off device has a lower reaction temperature than a fusible plug and avoids in the case of thermal overload the loss of the operation liquid by delivering a mechanical signal. By using the signal the drive system can be switched off.

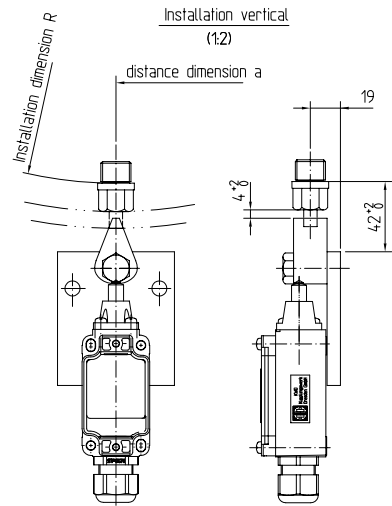
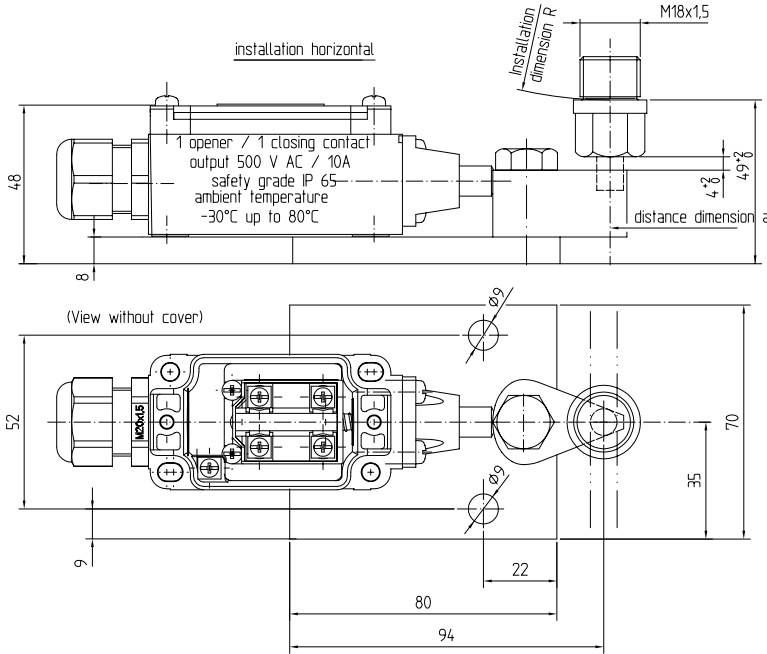

Wiring scheme (propose):

- L ... phase
- N ... centre
- A ... temperature switch
- F1 ... fuse
- H1 ... trouble lamp
- H2 ... horn
- K1 ... engine contactor
- S1 ... off - key
- S2 ... on - key

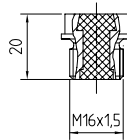
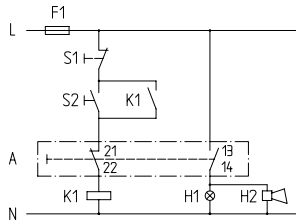

Installation dimension "R" and distance dimension "a" see offer- or installation drawing of the Turbocoupling

Tip

To compensation of installation and distance dimension tolerances of the Turbocoupling and the drive unit, provide on the base plate long bores and pan plates

----- flight path of the release temperature switch

device for assembly/disassembly on the shaft

For assembly of the hydrodynamic coupling on the shaft as well as for the disassembly a suitable tool to push on or to pull off has to be applied. These tool can be delivered together with the coupling on request as a kind of mechanical push on device and pull off spindle.

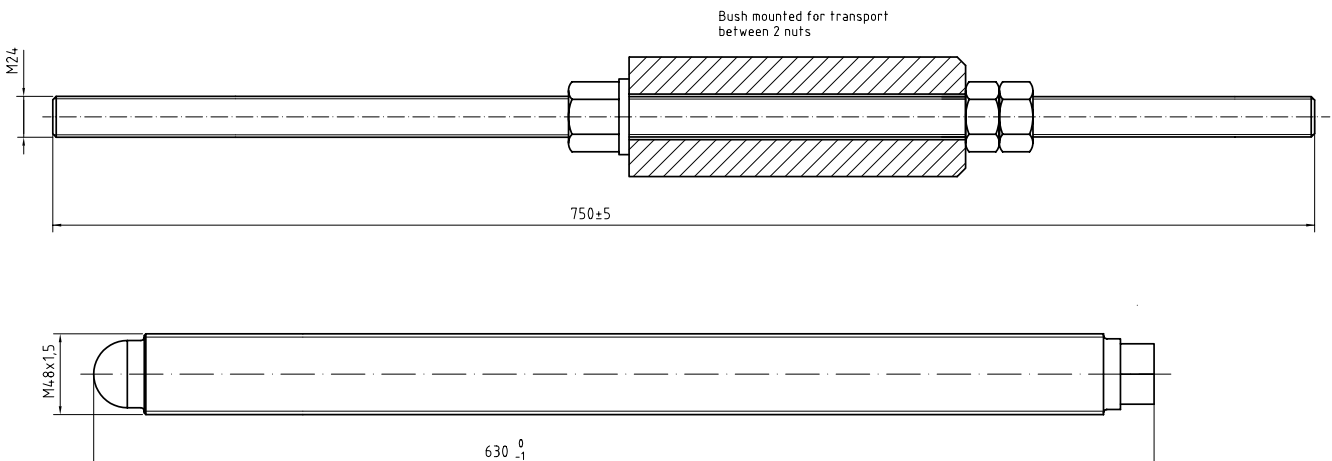



mobile crushers



long distance conveyor



belt conveyors



scraper conveyor



crusher station



pipe conveyor

company	<input type="text"/>		<input type="text"/>
	contact person		date
	<input type="text"/>	<input type="text"/>	
	phone	fax	
	<input type="text"/>		
E-mail			<input type="text"/>
<input type="text"/>	<input type="text"/>	<input type="text"/>	
inquiry no.	project	pieces	

installation conditions

starting device
 overload protection
 vibration damping
 desired start-up factor

power engine

type <input type="text"/>				
<input type="checkbox"/> electric motor	engine power	<input type="text"/> kW	rated speed	<input type="text"/> rpm
<input type="checkbox"/> diesel engine	starting frequency	<input type="text"/> x per day	direction change	<input type="text"/>
mounting dimensions		shaft diameter d_1	<input type="text"/> mm	
		shaft length l_1	<input type="text"/> mm	

working machine

type <input type="text"/>				
	moment of Inertia	<input type="text"/> kgm ²	based on	<input type="text"/> rpm
	req. power (nominal rating)	<input type="text"/> kW	max. power	<input type="text"/> kW
mounting dimensions		shaft diameter d_2	<input type="text"/> mm	
		shaft length l_2	<input type="text"/> mm	
		center bore	<input type="text"/>	

type of design

hydrodynamic coupling TK-N mounting on		<input type="checkbox"/> motorshaft	<input type="checkbox"/> gearbox shaft
installation position of the coupling		<input type="checkbox"/> horizontal <input type="checkbox"/> vertical	instance: vertical motor <input type="checkbox"/> up <input type="checkbox"/> down
radial demountability TK-N		<input type="checkbox"/> yes <input type="checkbox"/> no	
brake drum	<input type="checkbox"/> yes <input type="checkbox"/> no	dimensions of d_7	<input type="text"/> mm
brake disk	<input type="checkbox"/> yes <input type="checkbox"/> no	dimensions of d_{10}	<input type="text"/> mm
pulley	<input type="checkbox"/> yes <input type="checkbox"/> no	dimensions	effective diameter of d_w <input type="text"/> mm
		groove profile	<input type="text"/>
			number of grooves <input type="text"/>

remarks (quantity, special installation conditions (for example replacement of current coupling of the type ...), environmental conditions, etc.)

.....

.....

.....

date / sign



You sales partner



TYMA CZ, s.r.o.
Na Pískách 731/12
CZ - 400 04 Trmice
Tel.: +420 475 655 010
Fax: +420 475 655 018
E-mail: info@tyma.cz
<http://www.tyma.cz>



Certified in accordance with ISO 9001: 2008
Scope development, manufacture, sale
and servicing of couplings in the drive
technology field



Certified Welding
Company / GSI SLV